

HabiPLAST™

Extruded and Machined
Thermoplastic Profiles:
Wear Strips and Guides

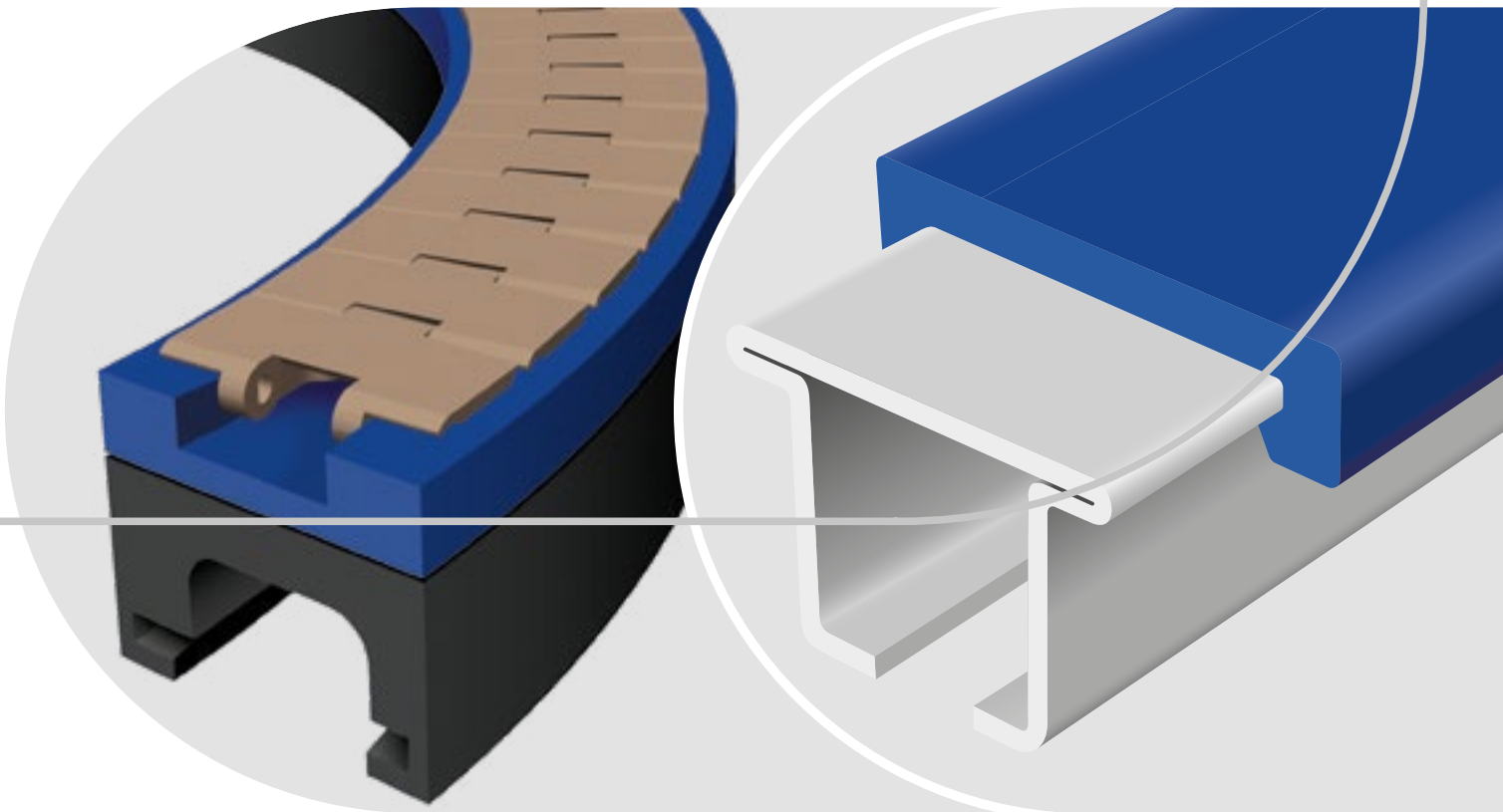

Unlimited use of Habiplast™ products	4
Materials overview	6
Pictorial Index	8
Wear strips and guides for plastic modular belts, chains and goods	8
Chain tracks	10
Guides for timing belts	11
Guides for round and V-belts	11
Guides for roller chains	12
Accessories	13
Wear strips and guides for plastic modular belts, chains and goods - Description and Code structure	14
Chain tracks - Description and Code structure	36
Guides for Habasynk® timing belts, round belts, V-belts and roller chains Description and Code structure	48
Accessories	66
Habiplast™ standard materials	70
Habiplast™ materials for machined parts	73
Material combinations	74
Habiplast™ materials for sliding/tribological applications	76

HabiPLAST™

Beyond its leadership in production and sales of conveyor belts, Habasit has been developing along the years a comprehensive range of plastic accessories for conveyors, which has been identified by the HabiPLAST™ trade mark. Most of these products are strictly in contact with the conveyor belt, so they represent an essential part of the recognized success of the Habasit solutions: profiles, guides for plastic modular belts and chains, sprockets, guides for goods, other plastic parts, etc.

Industries and applications

HabiPLAST™ products are used in many industries and are the best complement for HabasitLINK® modular belts, HabaCHAIN® slat and conveyor chains, and HabaSYNC® timing belts.

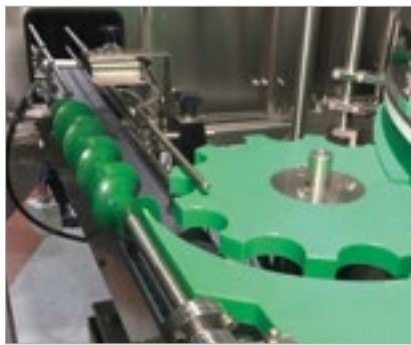

Food

- Bakery
- Meat
- Fish & Seafood
- Poultry
- Dairy
- Fruit & Vegetables

Bottling Industry

Materials Handling

- Distribution centers
- General conveyor systems

Airports

- Baggage handling

Automotive

- Assembling operations
- Tires
- Vehicle Batteries

Paper

Packaging

- Packaging machinery

Fitness & Leisure

- Leisure park applications
- Winter applications

Chemistry

Production

For the development of the Habiplast™ product range, Habasit has built a comprehensive knowledge in plastic processing: RAM extrusion, screw extrusion, machining and, of course, molding. Our Producing Units are equipped with the most technologically advanced machines and equipment. Extrusion and CNC machines guarantee a remarkable flexibility and big productive volumes always of high quality. Our stock of standard products ensures deliveries on time. In addition to the standard products which are available in the catalogue, several plastic parts are also machined on customers' drawings.

Competence and experience

Habasit application engineers and technicians are at your disposal to provide professional consulting and technical support.

With more than 70 years of experience and a comprehensive global network, Habasit is able to respond to any request and to satisfy specific needs with an optimal tailored solution.

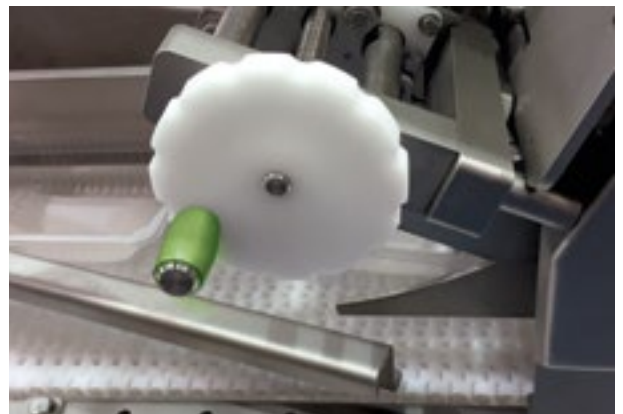
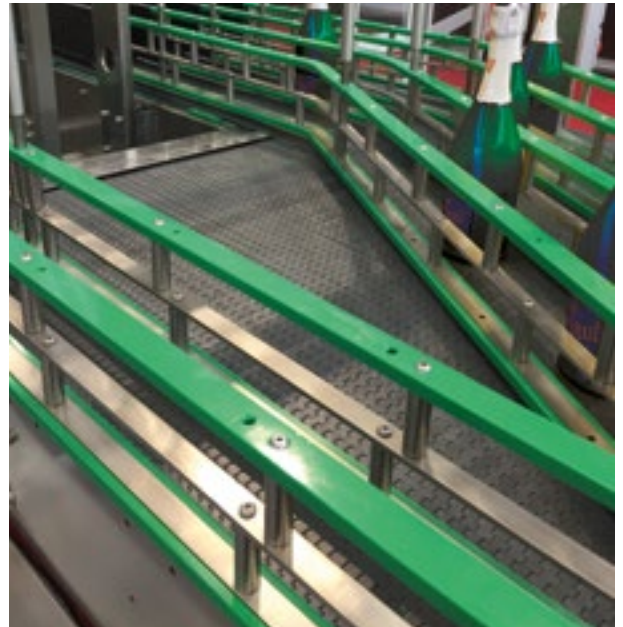
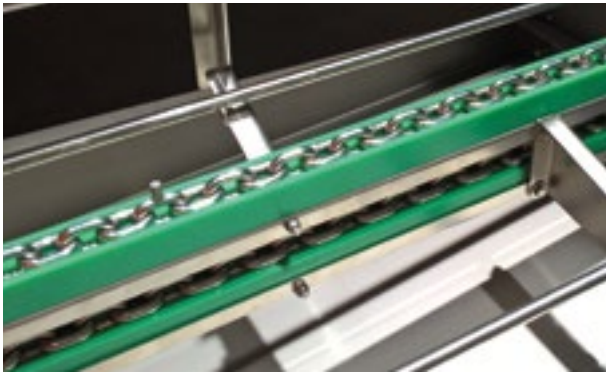

Habasit standard engineering polymers

Habasit offers a wide range of materials in order to satisfy all customers' needs.

Polyethylene is the most widely used engineering plastic material for belting profiles.



HabiPLAST™ polyethylene

HabiPLAST™ offers a wide range of high density polyethylene obtained by a low pressure polymerization process. The average molecular weight is between 0.3 and 8 millions of g/mol (measured by a viscometer). Ultra High Molecular Weight (UHMW-PE) identifies the polyethylene with more than 1 million of g/mol.

As the molecular weight of PE increases, so do its mechanical properties, including wear and impact resistance, tensile strength at a high temperatures, and energy absorption.

Additives such as fillers or lubricants can be used to further improve several technical properties, depending on the specific application requirements.

TriboPLUS®

TriboPlus® represents a new generation of polyethylene with the highest performances in terms of low friction coefficient and high wear resistance.

Compared to the standard UHMW polyethylene (PE40), laboratory tests showed the following properties of TriboPlus® (TP40):

Product properties	Your benefit
Lower friction	Energy savings
Less noise	Improved working conditions
Higher wear resistance	Less dusting – More Hygiene
Higher speed and load limits	Higher productivity
Self-lubrication	Less maintenance
Longer life	Lower operational costs



Convincing results for higher productivity and energy savings

LOWER FRICTION

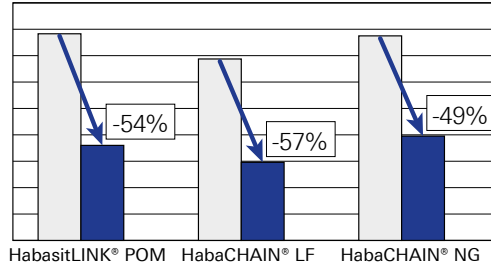

The TriboPlus® formulation is particularly suitable for the production of profiles for belts and chain but also for straight, and corner tracks, which are often subject to high friction, and wear.

In addition to the standard version, the TriboPlus® profiles can be provided with the special ESD (Electro Static Discharge) Polyethylene. TriboPlus® is compliant to the EU 10/2011 and FDA food regulations.

LOWER WEAR RATE

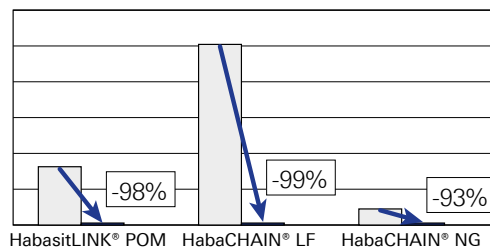

INCREASED LOAD LIMIT FOR POM

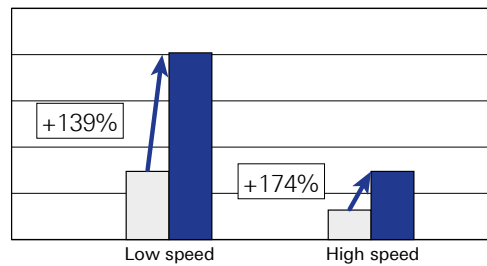

PE UHMW HabiPLAST TriboPlus®

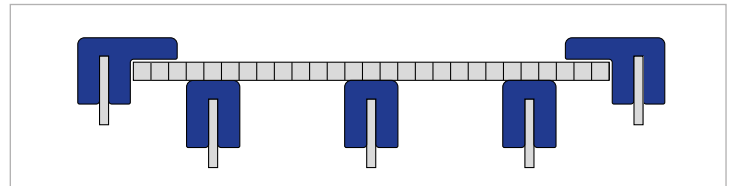
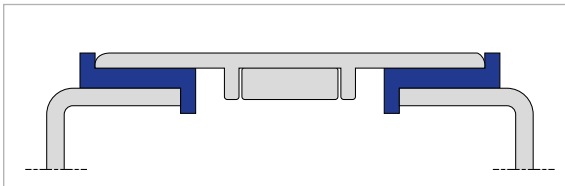

Other engineering plastic materials





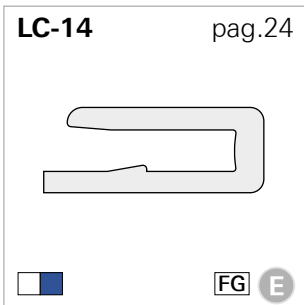
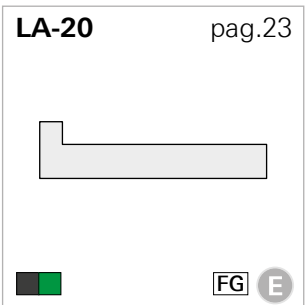
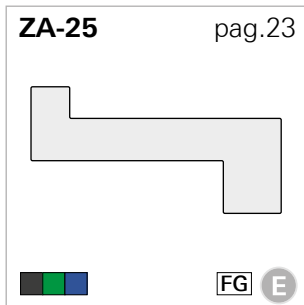
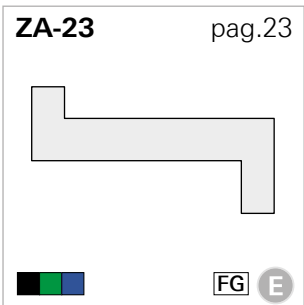
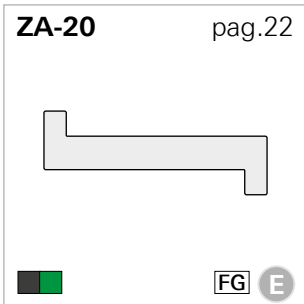
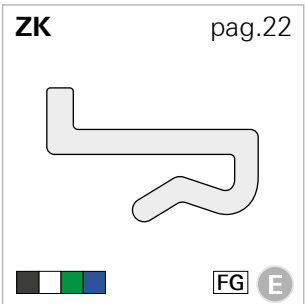
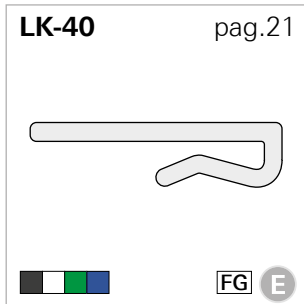
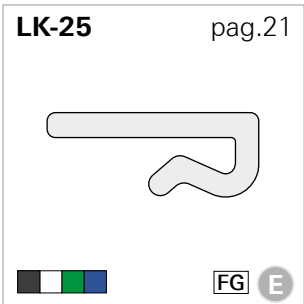
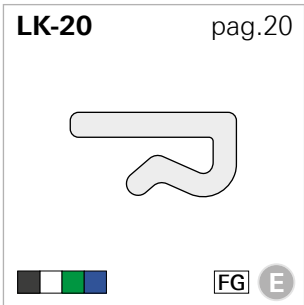
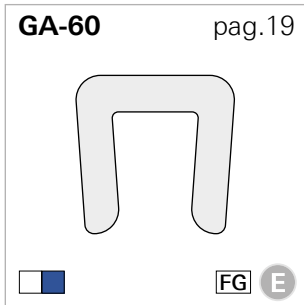
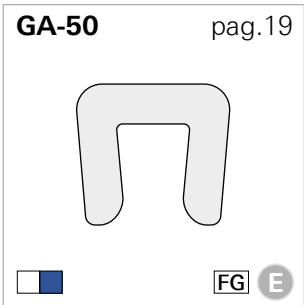
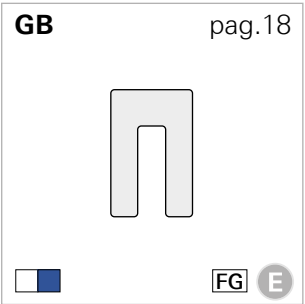
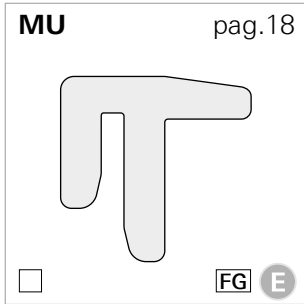
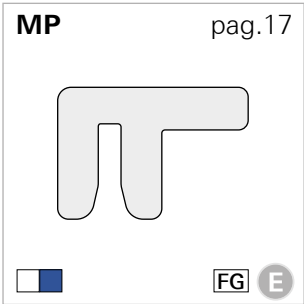
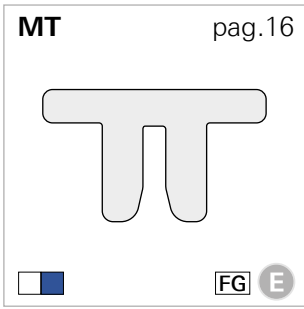
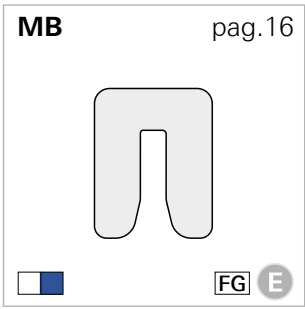

While extruded profiles are only made of polyethylene, there is a consistent part of the HabiPLAST™ product range which is manufactured using different engineering plastic materials (PA, POM, PET...).

HabiPLAST™ Food approved materials strictly comply to the EU and FDA regulations. Food certifications are available on the www.habasit.com web site.

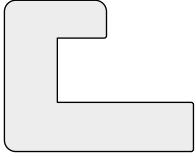
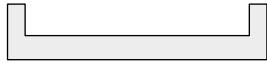
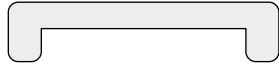
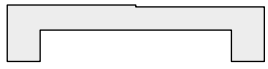
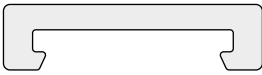
Wear strips and guides for plastic modular belts, chains and goods

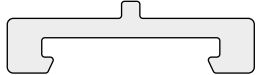
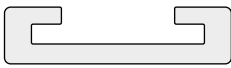
Description and Code structure pag. 14

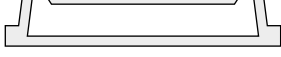
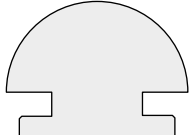
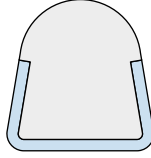
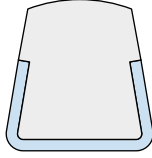
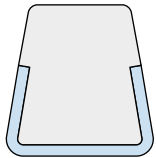
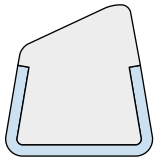
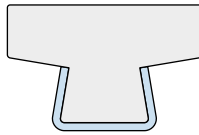
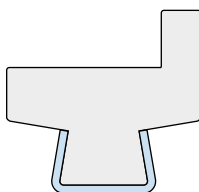

<p>LJ-85 pag.24</p>  <p>■ FG E</p>	<p>UD-70 pag.24</p>  <p>■ FG E</p>	<p>UA-41 pag.25</p>  <p>■ ■ ■ FG E</p>	<p>UB-41 pag.25</p>  <p>■ ■ FG E</p>
<p>US-40 pag.26</p>  <p>■ ■ ■ ■ FG E</p>	<p>TA-40 pag.26</p>  <p>■ FG E</p>	<p>TU-43 pag.27</p>  <p>■ FG E</p>	<p>TS-43 pag.27</p>  <p>■ FG E</p>
<p>CA-40 pag.28</p>  <p>■ ■ ■ ■ FG E</p>	<p>CA-50 pag.28</p>  <p>■ ■ ■ FG M</p>	<p>CA-60 pag.29</p>  <p>■ ■ ■ ■ FG M</p>	<p>CA-81 pag.29</p>  <p>■ ■ ■ ■ FG M</p>
<p>DG-78 pag.30</p>  <p>■ E</p>	<p>RA-18 pag.30</p>  <p>■ ■ FG E</p>	<p>RR-17 pag.31</p>  <p>□ FG E</p>	<p>RS-17 pag.31</p>  <p>□ FG E</p>
<p>RF-17 pag.31</p>  <p>□ FG E</p>	<p>RI-17 pag.32</p>  <p>□ FG E</p>	<p>RT-32 pag.32</p>  <p>□ FG E</p>	<p>RL32 pag.32</p>  <p>□ FG E</p>

Extruded **E** Machined **M**

Black (non Food Grade) ■ Natural white □ Green ■ Cobalt blue ■ Food Grade **FG**

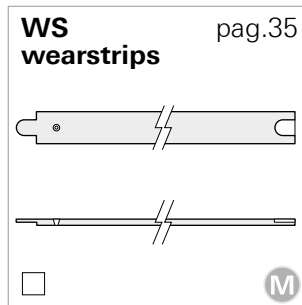
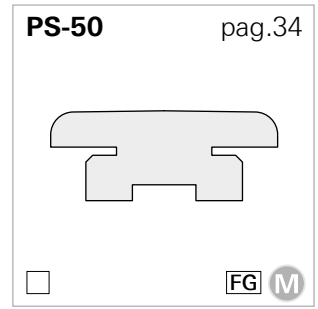
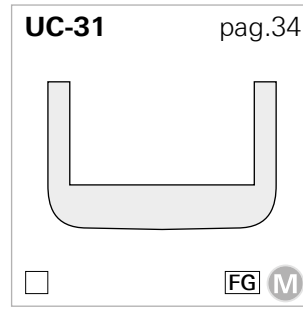
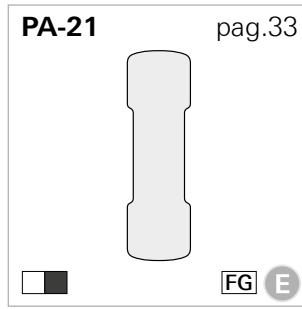
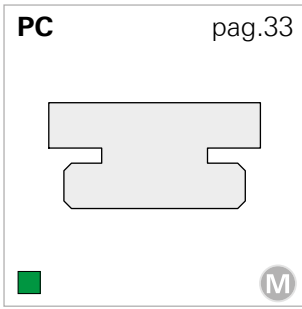

Chain tracks

Description and Code structure pag. 36

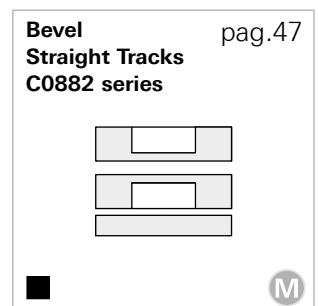
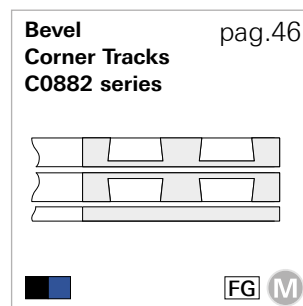
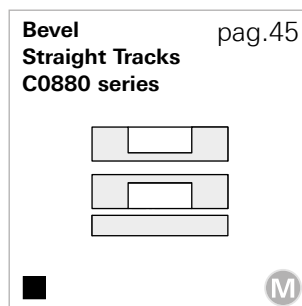
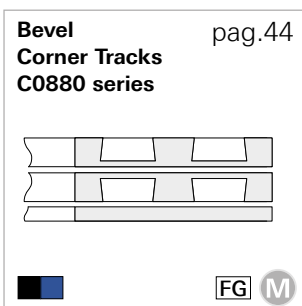
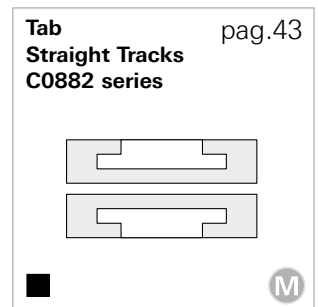
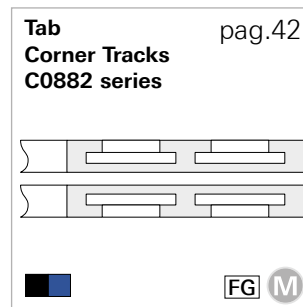
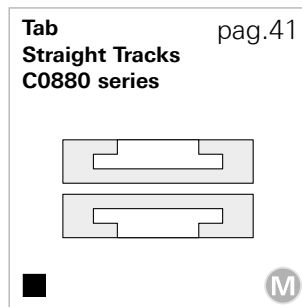
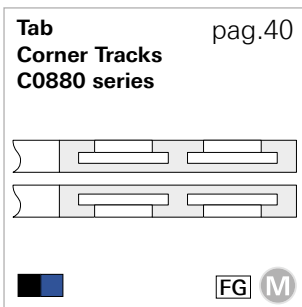
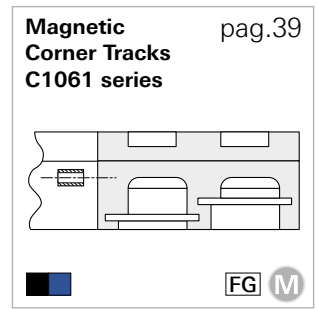
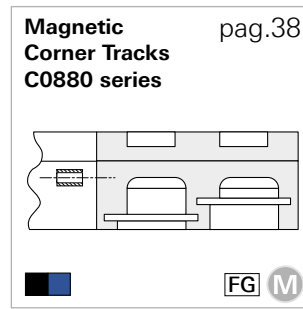

Guides for timing belts

Description and Code structure pag. 48

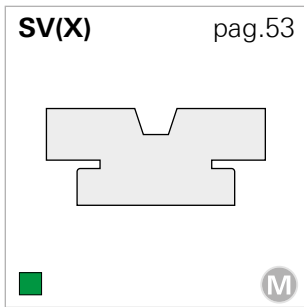
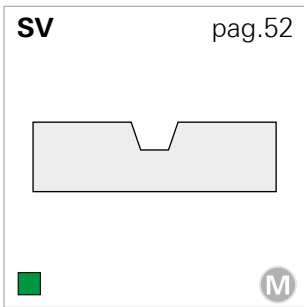
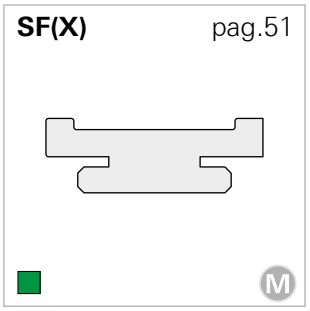
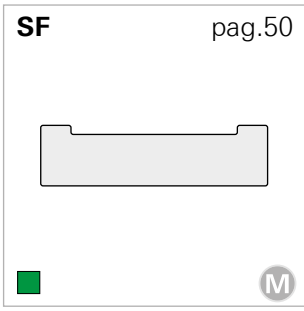

Guides for round and V-belts

Description and Code structure pag. 48

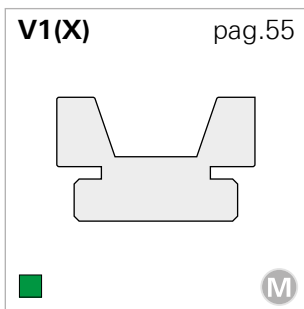
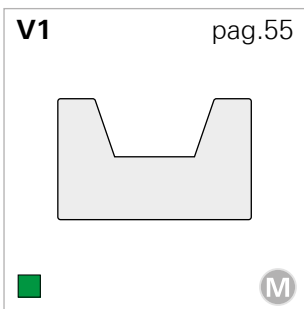
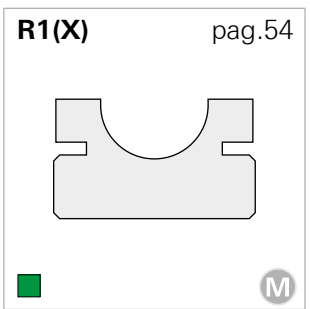
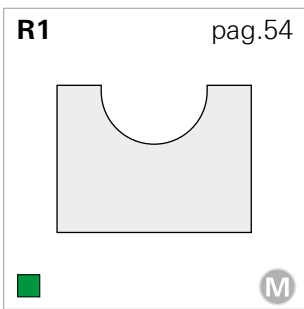

Guides for roller chains
Description and Code structure pag. 48

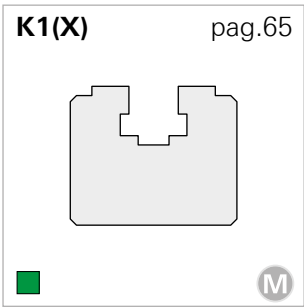
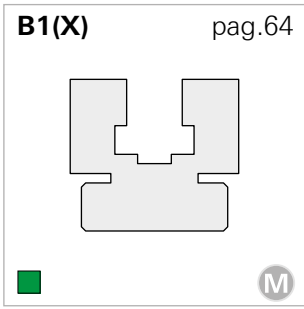
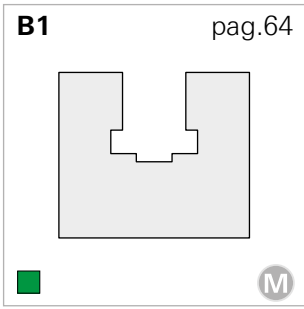
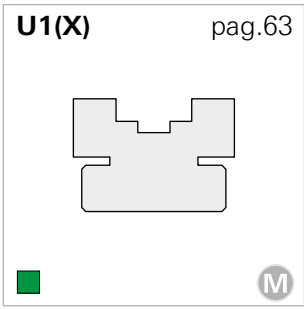
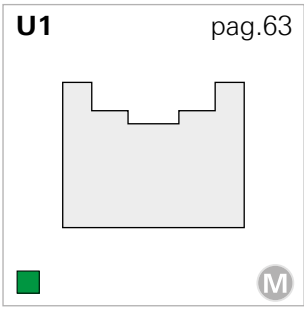
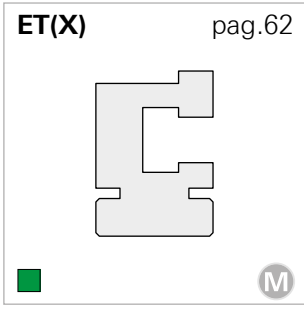
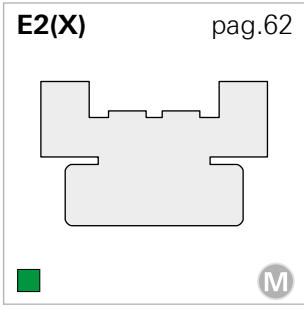
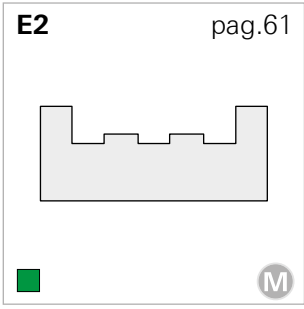
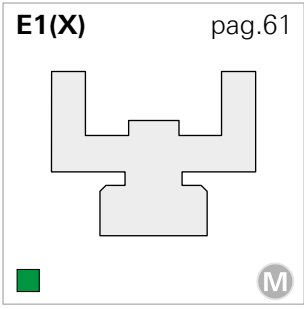
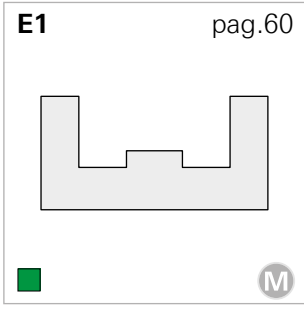
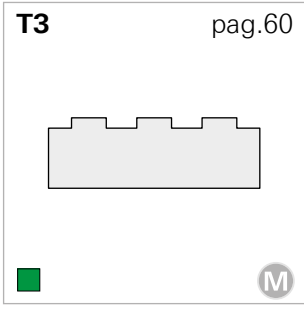
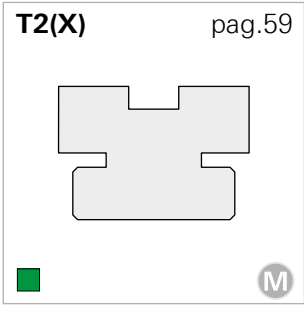
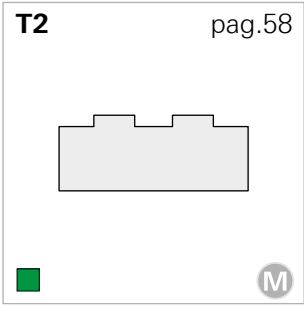
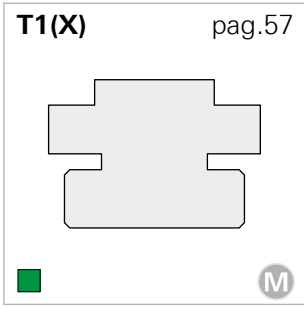
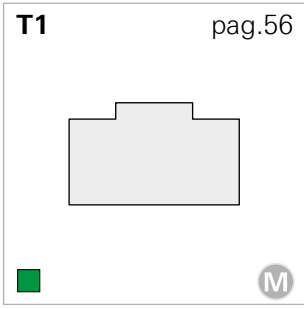

Accessories

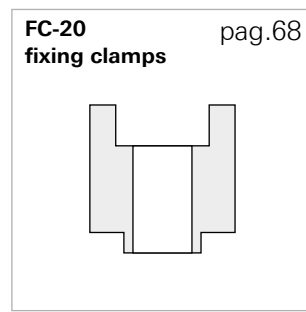
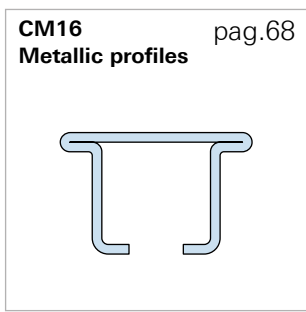
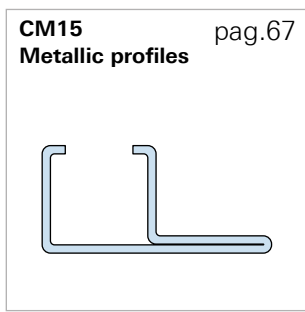
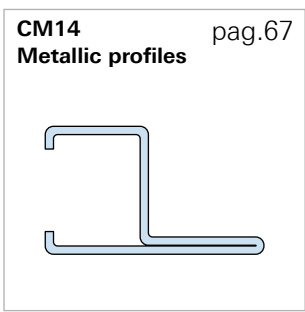
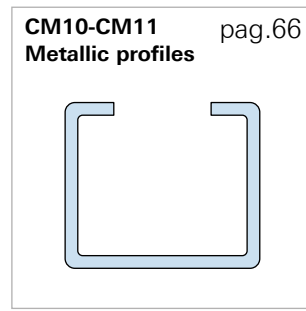
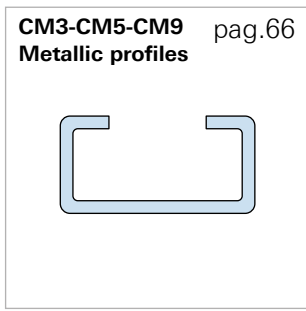

Wear strips and guides for plastic modular belts, chains and goods

HabiPLAST™ profiles represent the best solution not only to support and guide HabasitLINK plastic modular belts, HabaCHAIN plastic and metal chains, but also to guide goods along the conveyor.

The wide range of standard extruded profiles allows to find a suitable and “easy to assemble” solution for the most common conveyor structures. Customized machined profiles are also available for any special application.

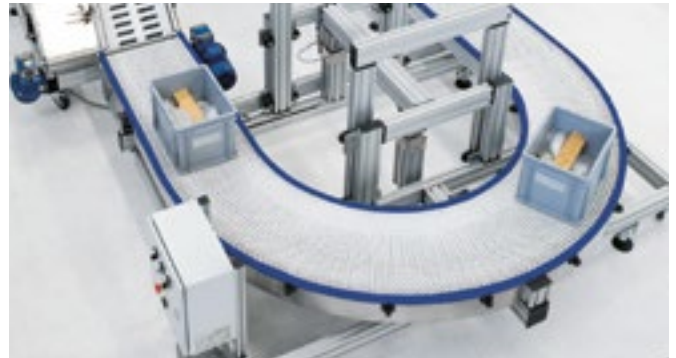

The HabiPLAST wear strips and guides for plastic modular belts, chains and goods are mainly produced in ultra-high molecular weight polyethylene.

The most relevant features are:

- Low friction
- Wear resistance
- Low noise
- Good impact resistance
- High chemical resistance
- Corrosion resistance
- Food compliancy

Our UHMW PE40 is the mostly used techno polymer for standard applications.

Whenever very low friction and high wear resistance are required, all the HabiPLAST™ profiles can be manufactured in TriboPlus, the special lubricated Polyethylene with outstanding tribological properties, developed by Habasit (see catalogue introduction for further information).

For low demanding applications, the HabiPLAST™ product range also includes a cost effective regenerated PE10.



Wear strips and guides for plastic modular belts, chains and goods

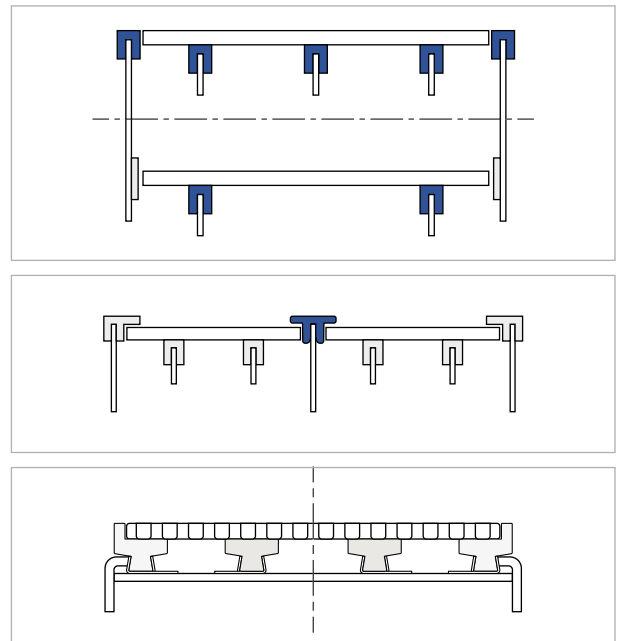
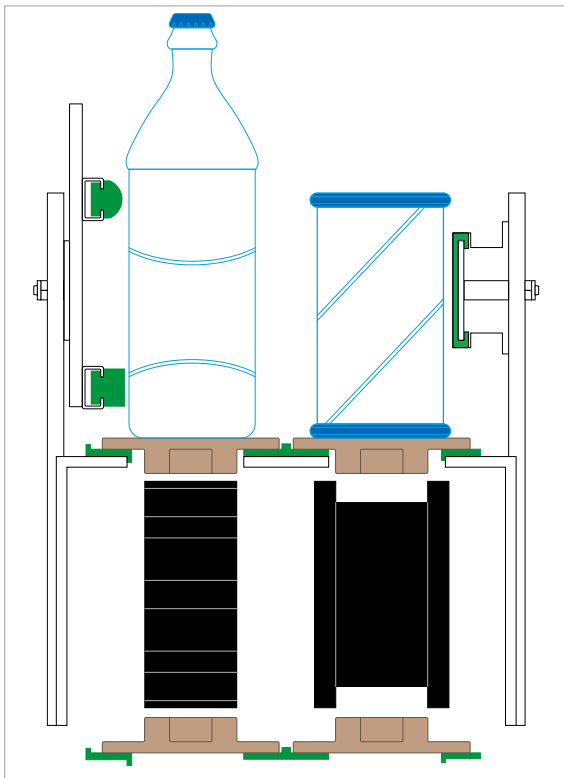

Code structure

Pos. 1-2	Pos. 3 - 4 - 5	Pos. 6	Pos. 7 - 8 - 9 - 10	Pos. 11	Pos. 12	Pos. 13 - 14 - 15	Pos. 16	Pos. 17 - 18									
L	K	-	2	5	-	P	E	4	0	W	-	0	0	3	+	F	G

Product series (profile design)	Profile identification number		Material	Color	Dimension (meters)	Special features
<p>V= AISI 304 assembled metal housing</p> <p>W= AISI 430 assembled metal housing</p>	<p>The number normally identifies the main profile dimensions</p>		<p>PE03-PE05--PE10</p> <p>PE40-PE80-TP40</p> <p>PA6E-PA6 -PA66</p> <p>POMC</p> <p>PP00</p> <p>PTFE</p> <p>PVC0</p> <p>PETC</p> <p>GALV-A304-A430</p> <p>ALUM</p>	<p>B = black</p> <p>W = natural white</p> <p>G = green</p> <p>C = cobalt blue</p> <p>D = Gray</p> <p>Y = yellow</p> <p>R = red</p> <p>A = orange</p> <p>N = brown</p>		<p>FG=food grade</p> <p>EC=conductive</p> <p>FE=food grade + conductive</p> <p>RC=recycled</p> <p>RK=recycled confetti structure</p> <p>LF=low friction</p> <p>MO=MoS2</p> <p>AR=antistatic recycled</p> <p>G1=Glass fiber reinforced 10%</p> <p>G2=Glass fiber reinforced 5% (US 13%)</p> <p>G3=Glass fiber reinforced 20%</p> <p>G4=Glass fiber reinforced 25%</p> <p>G5=Glass fiber reinforced 30% (US 33%)</p>

*: see Product Data Sheets for available materials, colors, dimensions and features.

MB profile

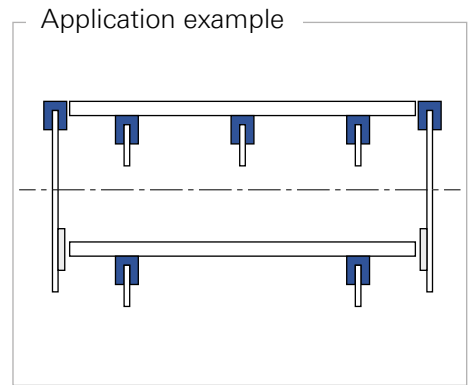
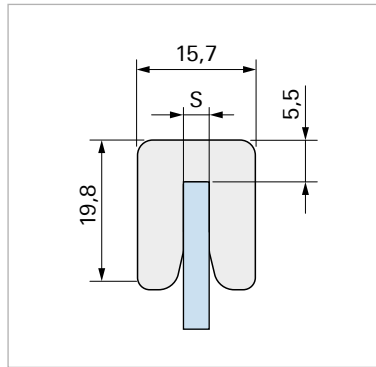
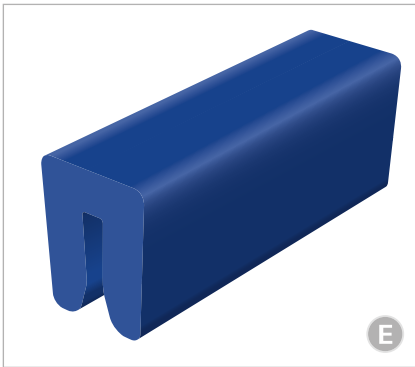

Habasit code	s	Material	Color	Packaging unit	Total length	Food grade
	mm				m	
MB-22-PE40W-003+FG	2	PE40	white <input type="checkbox"/>	bar	3	•
MB-22-PE40W-006+FG	2	PE40	white <input type="checkbox"/>	bar	6	•
MB-22-TP40C-003+FG	2	TP40	c-blue <input checked="" type="checkbox"/>	bar	3	•
MB-27-PE40W-003+FG	2,5	PE40	white <input type="checkbox"/>	bar	3	•
MB-27-PE40W-006+FG	2,5	PE40	white <input type="checkbox"/>	bar	6	•
MB-27-TP40C-003+FG	2,5	TP40	c-blue <input checked="" type="checkbox"/>	bar	3	•
MB-32-PE40W-003+FG	3	PE40	white <input type="checkbox"/>	bar	3	•
MB-32-PE40W-006+FG	3	PE40	white <input type="checkbox"/>	bar	6	•
MB-32-TP40C-003+FG	3	TP40	c-blue <input checked="" type="checkbox"/>	bar	3	•
MB-47-PE40W-003+FG	4,5	PE40	white <input type="checkbox"/>	bar	3	•
MB-47-PE40W-006+FG	4,5	PE40	white <input type="checkbox"/>	bar	6	•
MB-47-TP40C-003+FG	4,5	TP40	c-blue <input checked="" type="checkbox"/>	bar	3	•
MB-52-PE40W-003+FG	5	PE40	white <input type="checkbox"/>	bar	3	•
MB-52-PE40W-006+FG	5	PE40	white <input type="checkbox"/>	bar	6	•
MB-52-TP40C-003+FG	5	TP40	c-blue <input checked="" type="checkbox"/>	bar	3	•

MT profile

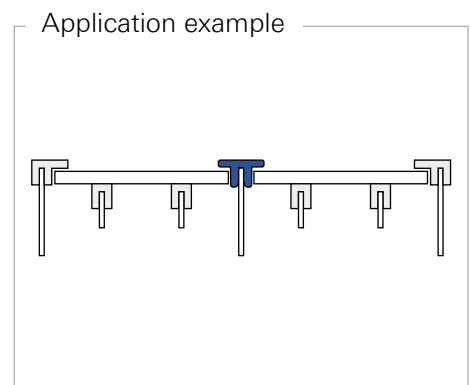
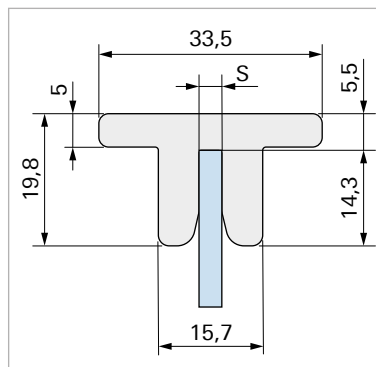
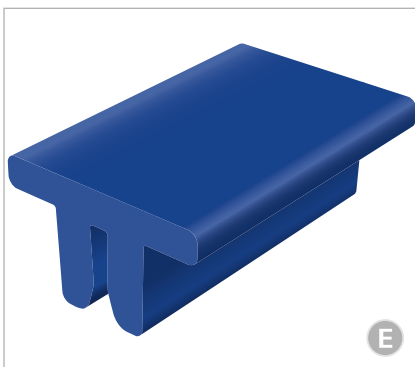

Habasit code	s	Material	Color	Packaging unit	Total length	Food grade
	mm				m	
MT-22-PE40W-003+FG	2	PE40	white <input type="checkbox"/>	bar	3	•
MT-22-PE40W-006+FG	2	PE40	white <input type="checkbox"/>	bar	6	•
MT-22-TP40C-003+FG	2	TP40	c-blue <input checked="" type="checkbox"/>	bar	3	•
MT-27-PE40W-003+FG	2,5	PE40	white <input type="checkbox"/>	bar	3	•



MT profile

Habasit code	s	Material	Color	Packaging unit	Total length	Food grade
	mm					
MT-27-PE40W-006+FG	2,5	PE40	white <input type="checkbox"/>	bar	6	•
MT-27-TP40C-003+FG	2,5	TP40	c-blue <input checked="" type="checkbox"/>	bar	3	•
MT-27-TP40C-006+FG	2,5	TP40	c-blue <input checked="" type="checkbox"/>	bar	6	•
MT-32-PE40W-003+FG	3	PE40	white <input type="checkbox"/>	bar	3	•
MT-32-PE40W-006+FG	3	PE40	white <input type="checkbox"/>	bar	6	•
MT-32-TP40C-003+FG	3	TP40	c-blue <input checked="" type="checkbox"/>	bar	3	•
MT-45-PE40W-003+FG	4,5	PE40	white <input type="checkbox"/>	bar	3	•
MT-45-PE40W-006+FG	4,5	PE40	white <input type="checkbox"/>	bar	6	•
MT-45-TP40C-003+FG	4,5	TP40	c-blue <input checked="" type="checkbox"/>	bar	3	•

MP profile

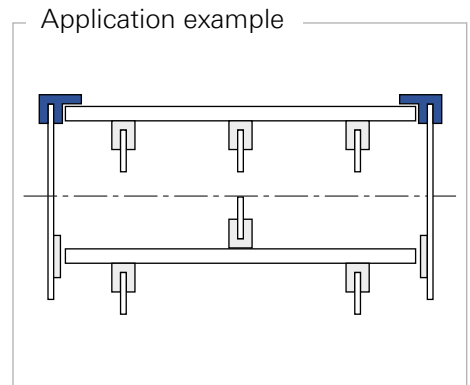
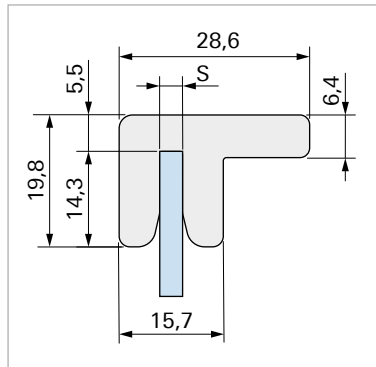
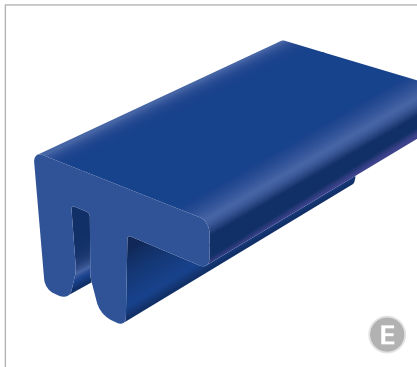

Habasit code	s	Material	Color	Packaging unit	Total length	Food grade
	mm					
MP-22-PE40W-003+FG	2	PE40	white <input type="checkbox"/>	bar	3	•
MP-22-PE40W-006+FG	2	PE40	white <input type="checkbox"/>	bar	6	•
MP-22-TP40C-003+FG	2	TP40	c-blue <input checked="" type="checkbox"/>	bar	3	•
MP-27-PE40W-003+FG	2,5	PE40	white <input type="checkbox"/>	bar	3	•
MP-27-PE40W-006+FG	2,5	PE40	white <input type="checkbox"/>	bar	6	•
MP-27-TP40C-003+FG	2,5	TP40	c-blue <input checked="" type="checkbox"/>	bar	3	•
MP-32-PE40W-003+FG	3	PE40	white <input type="checkbox"/>	bar	3	•
MP-32-PE40W-006+FG	3	PE40	white <input type="checkbox"/>	bar	6	•
MP-32-TP40C-003+FG	3	TP40	c-blue <input checked="" type="checkbox"/>	bar	3	•
MP-47-PE40W-003+FG	4,5	PE40	white <input type="checkbox"/>	bar	3	•
MP-47-PE40W-006+FG	4,5	PE40	white <input type="checkbox"/>	bar	6	•
MP-47-TP40C-003+FG	4,5	TP40	c-blue <input checked="" type="checkbox"/>	bar	3	•
MP-52-PE40W-003+FG	5	PE40	white <input type="checkbox"/>	bar	3	•
MP-52-PE40W-006+FG	5	PE40	white <input type="checkbox"/>	bar	6	•
MP-52-TP40C-003+FG	5	TP40	c-blue <input checked="" type="checkbox"/>	bar	3	•

MU profile

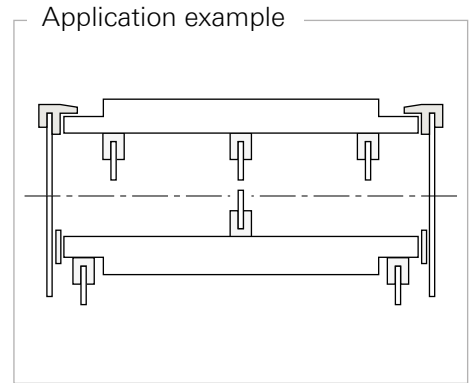
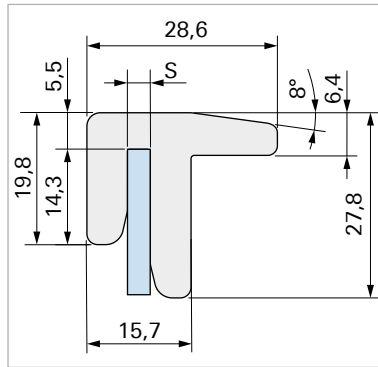

Habasit code	s	Material	Color	Packaging unit	Total length	Food grade
	mm					
MU-32-PE40W-003+FG	3	PE40	white <input type="checkbox"/>	bar	3	•
MU-47-PE40W-003+FG	4,5	PE40	white <input type="checkbox"/>	bar	3	•

GB profile

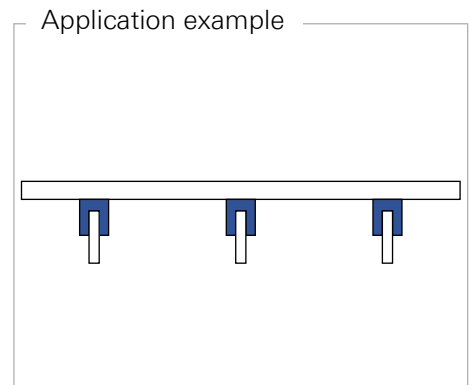
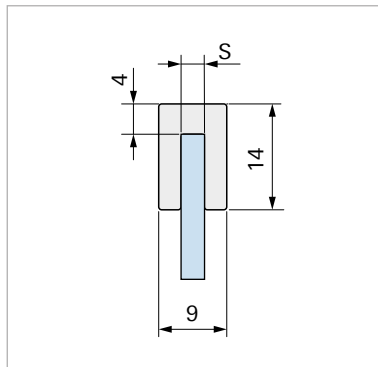
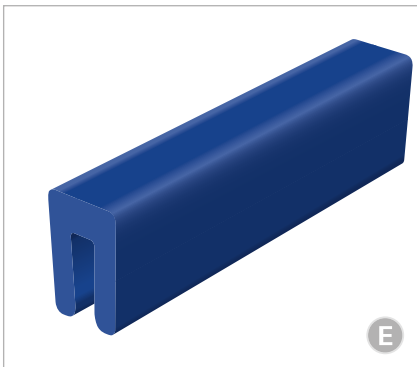

Habasit code	s	Material	Color	Packaging unit	Total length	Food grade
	mm					
GB-22-PE40W-050+FG	2	PE40	white <input type="checkbox"/>	coil	50	•
GB-22-TP40C-050+FG	2	TP40	c-blue <input checked="" type="checkbox"/>	coil	50	•
GB-32-PE40W-050+FG	3	PE40	white <input type="checkbox"/>	coil	50	•
GB-32-TP40C-050+FG	3	TP40	c-blue <input checked="" type="checkbox"/>	coil	50	•
GB-42-PE40W-050+FG	4	PE40	white <input type="checkbox"/>	coil	50	•
GB-42-TP40C-050+FG	4	TP40	c-blue <input checked="" type="checkbox"/>	coil	50	•

GA-40 profile

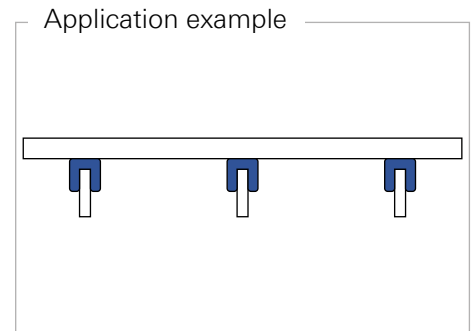
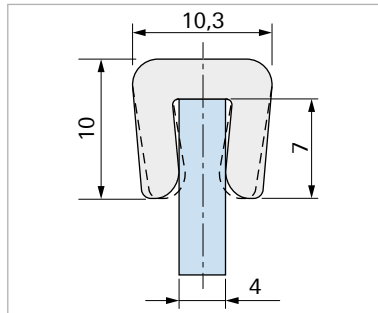
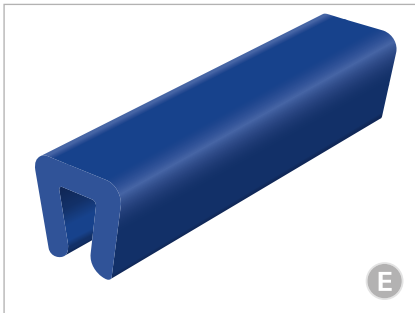

Habasit code	Material	Color	Packaging unit	Total length		Food grade
				m		
GA-40-PE40W-050+FG	PE40	white <input type="checkbox"/>	coil	50		•
GA-40-TP40C-050+FG	TP40	c-blue <input checked="" type="checkbox"/>	coil	50		•

GA-50 profile

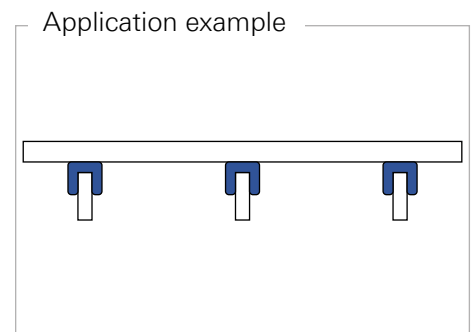
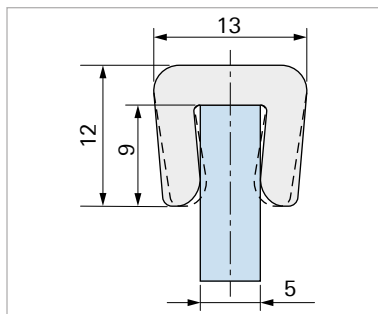
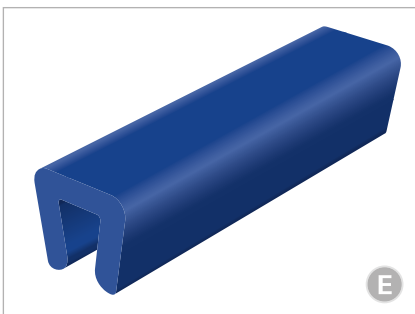

Habasit code	Material	Color	Packaging unit	Total length		Food grade
				m		
GA-50-PE40W-050+FG	PE40	white <input type="checkbox"/>	coil	50		•
GA-50-TP40C-050+FG	TP40	c-blue <input checked="" type="checkbox"/>	coil	50		•

GA-60 profile

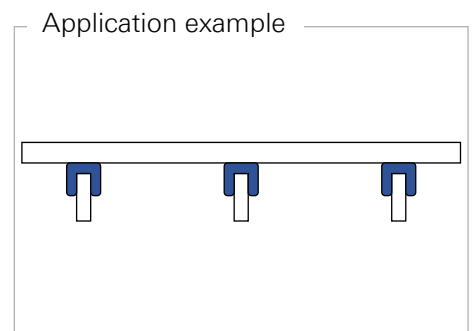
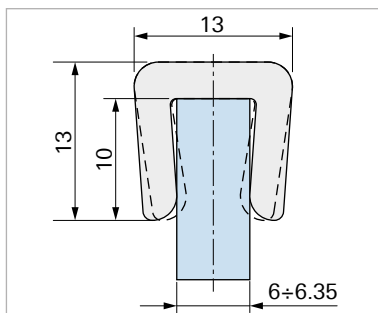
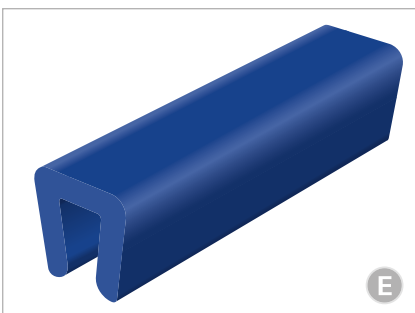

Habasit code	Material	Color	Packaging unit	Total length		Food grade
				m		
GA-60-PE40W-050+FG	PE40	white <input type="checkbox"/>	coil	50		•
GA-60-TP40C-050+FG	TP40	c-blue <input checked="" type="checkbox"/>	coil	50		•

GA100 profile

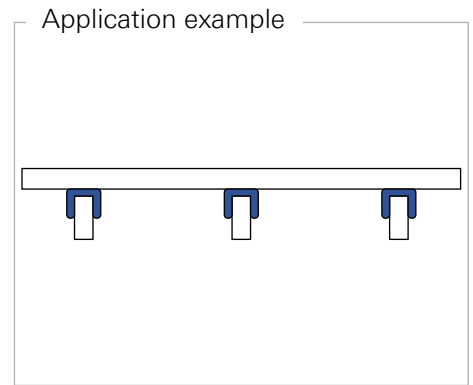
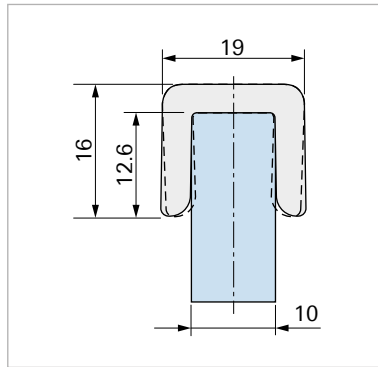
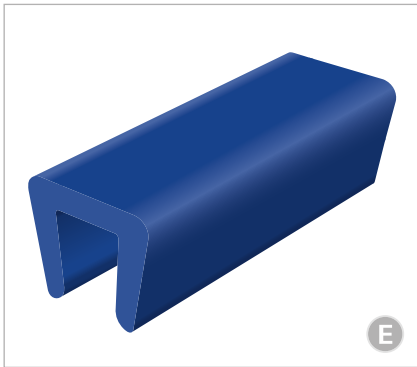

Habasit code	Material	Color	Packaging unit	Total length		Food grade
				m		
GA100-PE40W-030+FG	PE40	white <input type="checkbox"/>	coil	30		•
GA100-TP40C-030+FG	TP40	c-blue <input checked="" type="checkbox"/>	coil	30		•

LK-20 profile

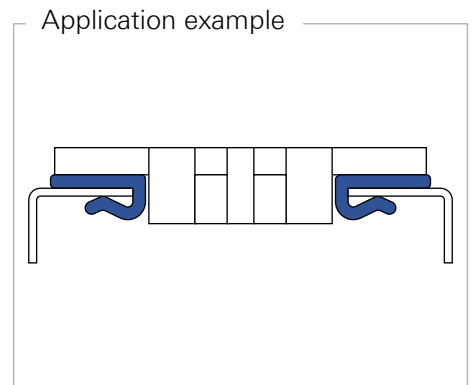
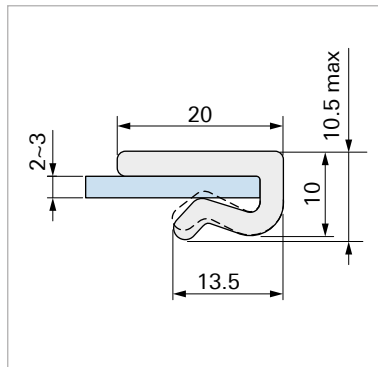

Habasit code	Material	Color	Packaging unit	Total length		Food grade
				m		
LK-20-PE10B-040+RC	PE10	black <input type="checkbox"/>	coil	40		
LK-20-PE40W-040+FG	PE40	white <input type="checkbox"/>	coil	40		•
LK-20-PE40G-040+FG	PE40	green <input type="checkbox"/>	coil	40		•
LK-20-TP40C-040+FG	TP40	c-blue <input checked="" type="checkbox"/>	coil	40		•

LK-25 profile

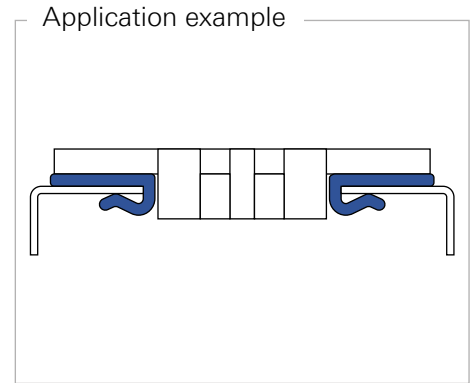
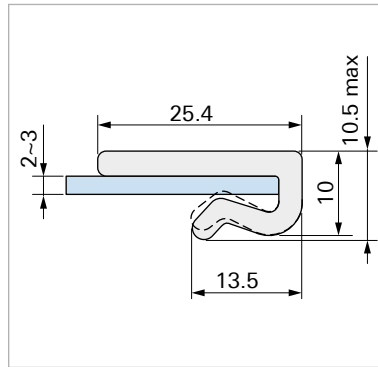
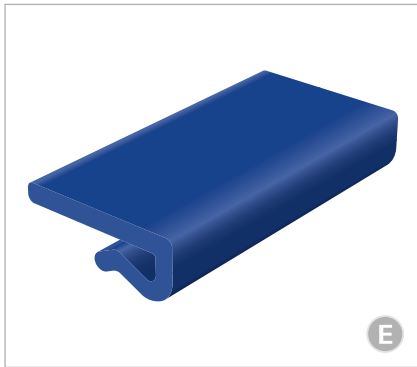

Habasit code	Material	Color	Packaging unit	Total length	
				m	Food grade
LK-25-PE10B-040+RC	PE10	black	coil	40	
LK-25-PE40W-040+FG	PE40	white	coil	40	•
LK-25-PE40G-040+FG	PE40	green	coil	40	•
LK-25-TP40C-040+FG	TP40	c-blue	coil	40	•

LK-40 profile

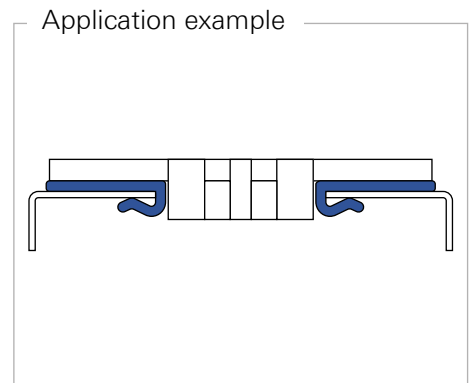
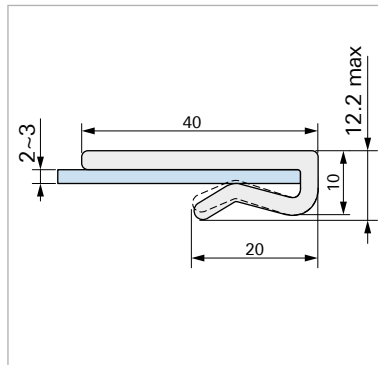
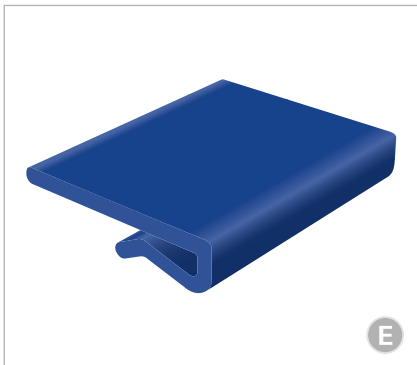

Habasit code	Material	Color	Packaging unit	Total length	
				m	Food grade
LK-40-PE10B-050+RC	PE10	black	coil	50	
LK-40-PE40W-050+FG	PE40	white	coil	50	•
LK-40-PE40G-050+FG	PE40	green	coil	50	•
LK-40-TP40C-050+FG	TP40	c-blue	coil	50	•

ZK profile

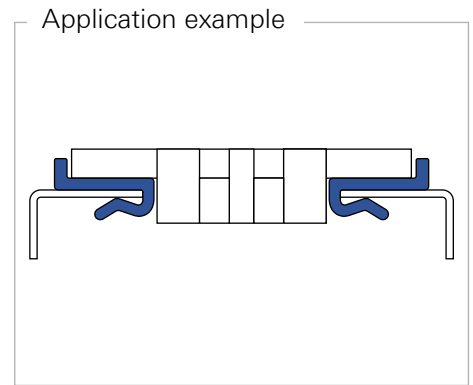
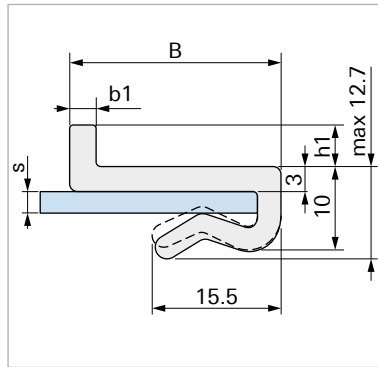
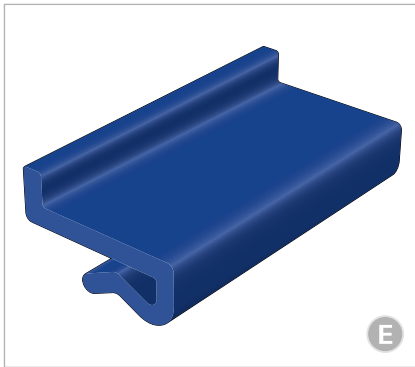

Habasit code	B	h1	b1	s	Material	Color	Packaging unit	Total length	Food grade
	mm	mm	mm	mm				m	
ZK-21-PE10B-040+RC	21	2	1,7	2~3	PE10	black	coil	40	
ZK-21-PE40W-040+FG	21	2	1,7	2~3	PE40	white	coil	40	•
ZK-21-PE40G-040+FG	21	2	1,7	2~3	PE40	green	coil	40	•
ZK-21-TP40C-040+FG	21	2	1,7	2~3	TP40	c-blue	coil	40	•
ZK-27-PE40W-040+FG	22,2	7,7	3,2	2~3	PE40	white	coil	40	•
ZK-27-TP40C-040+FG	22,2	7,7	3,2	2~3	TP40	c-blue	coil	40	•
ZK-29-PE40W-040+FG	22,2	9,7	3,2	2~3	PE40	white	coil	40	•
ZK-29-TP40C-040+FG	22,2	9,7	3,2	2~3	TP40	c-blue	coil	40	•
ZK-53-PE40W-040+FG	25,4	3,2	3,2	2~3	PE40	white	coil	40	•
ZK-53-TP40C-040+FG	25,4	3,2	3,2	2~3	TP40	c-blue	coil	40	•
ZK-55-PE40W-040+FG	25,4	5,0	3,2	2~3	PE40	c-blue	coil	40	•
ZK-55-TP40C-040+FG	25,4	5,0	3,2	2~3	TP40	c-blue	coil	40	•
ZK-57-PE40W-040+FG	25,4	7,7	3,2	2~3	PE40	white	coil	40	•
ZK-57-TP40C-040+FG	25,4	7,7	3,2	2~3	TP40	c-blue	coil	40	•
ZK-59-PE40W-040+FG	25,4	9,7	3,2	2~3	PE40	white	coil	40	•
ZK-59-TP40C-040+FG	25,4	9,7	3,2	2~3	TP40	c-blue	coil	40	•

ZA-20 profile

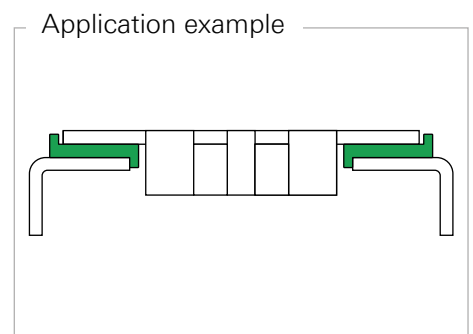
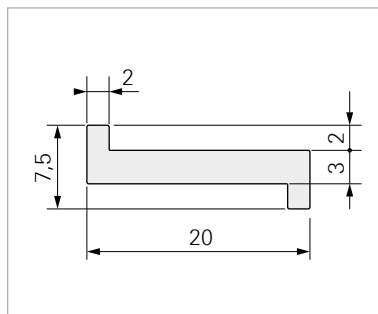
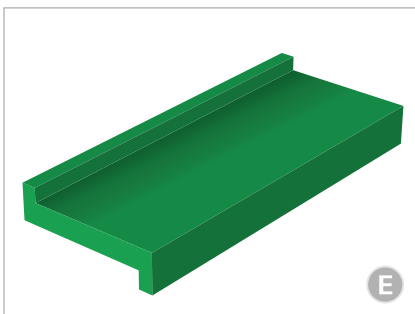

Habasit code	Material	Color	Packaging unit	Total length	Food grade
				m	
ZA-20-PE10B-050+RC	PE10	black	coil	50	
ZA-20-PE40G-050+FG	PE40	green	coil	50	•

ZA-23 profile

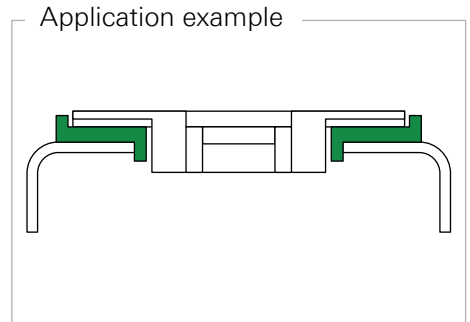
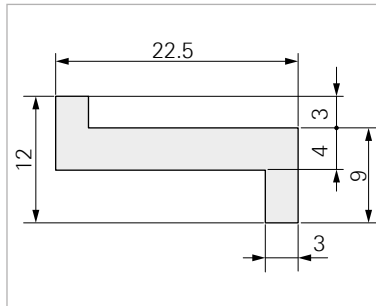
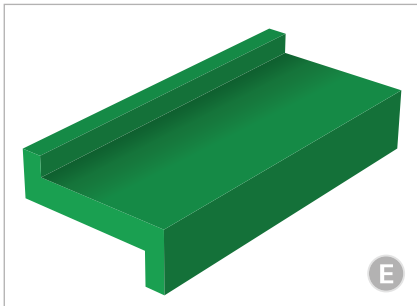

Habasit code	Material	Color	Packaging unit	Total length		Food grade
				m		
ZA-23-PE10B-050+RC	PE10	black	coil	50		
ZA-23-PE40G-050+FG	PE40	green	coil	50		•
ZA-23-TP40C-050+FG	TP40	c-blue	coil	50		•

ZA-25 profile

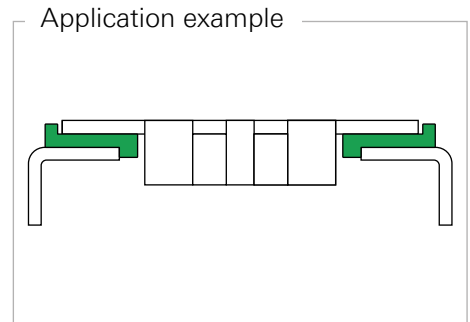
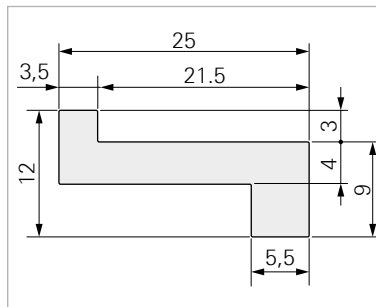
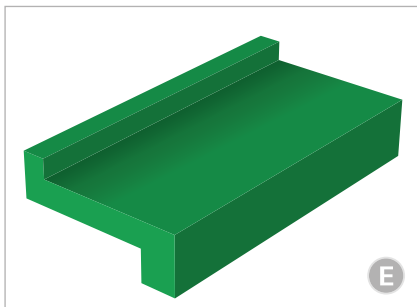

Habasit code	Material	Color	Packaging unit	Total length		Food grade
				m		
ZA-25-PE10B-050+RC	PE10	black	coil	50		
ZA-25-PE40G-050+FG	PE40	green	coil	50		•
ZA-25-TP40C-050+FG	TP40	c-blue	coil	50		•

LA-20 profile

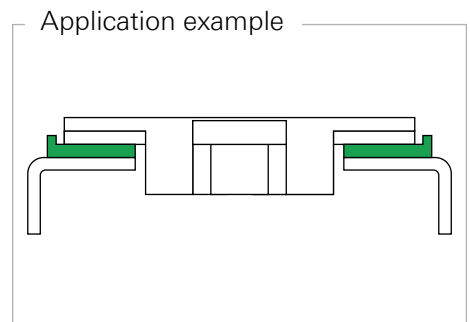
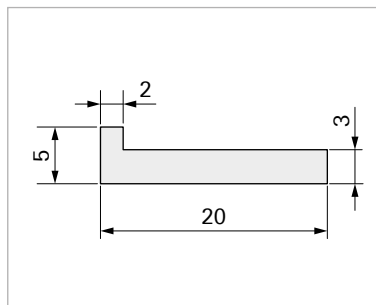
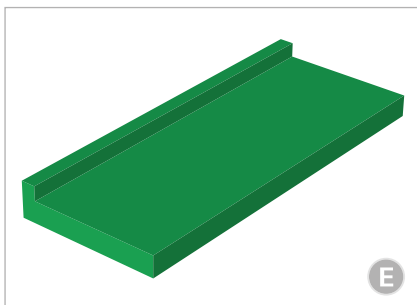

Habasit code	Material	Color	Packaging unit	Total length		Food grade
				m		
LA-20-PE10B-050+RC	PE10	black	coil	50		
LA-20-PE40G-050+FG	PE40	green	coil	50		•

LC-14 profile

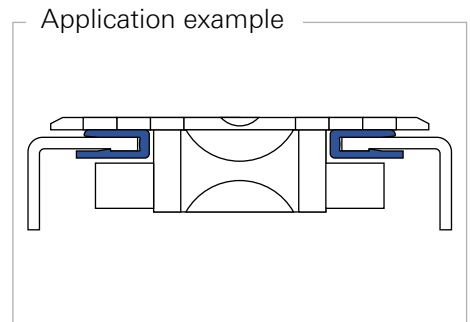
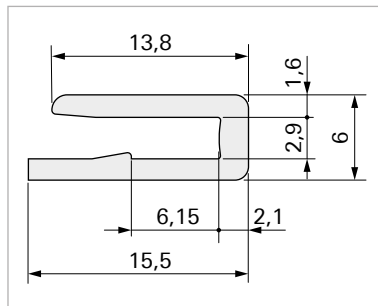
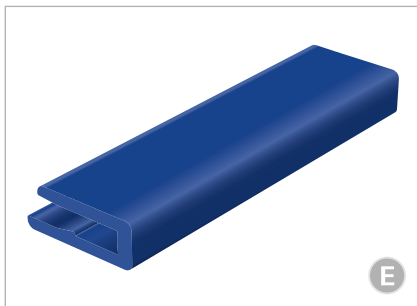

Habasit code	Material	Color	Packaging unit	Total length		Food grade
				m		
LC-14-PE40W-050+FG	PE40	white <input type="checkbox"/>	coil	50		•
LC-14-TP40C-050+FG	TP40	c-blue <input checked="" type="checkbox"/>	coil	50		•

LJ-85 profile

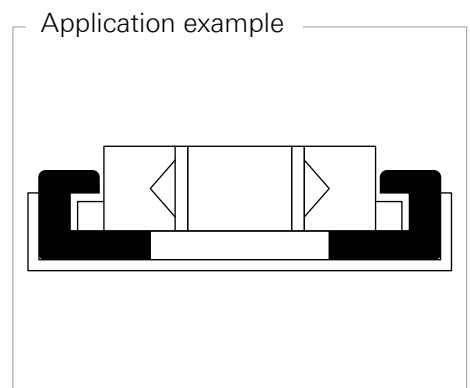
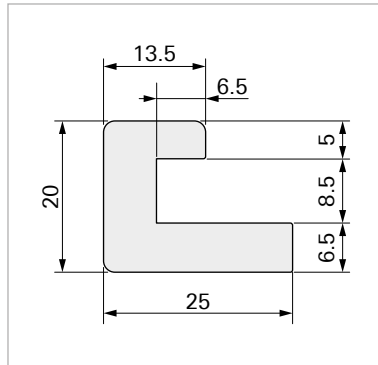
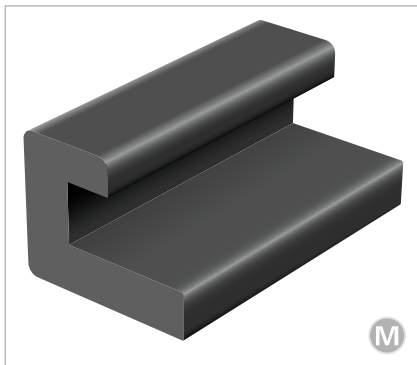

Habasit code	Material	Color	Packaging unit	Total length		Food grade
				m		
LJ-85-PE05W-003+FG	PE05	white <input type="checkbox"/>	bar	3		•
LJ-85-PE10B-003+RC	PE10	black <input checked="" type="checkbox"/>	bar	3		

UD-70 profile

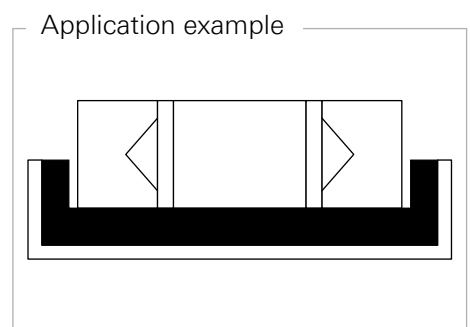
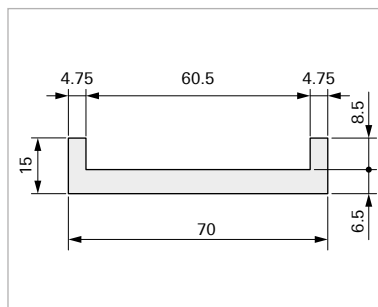
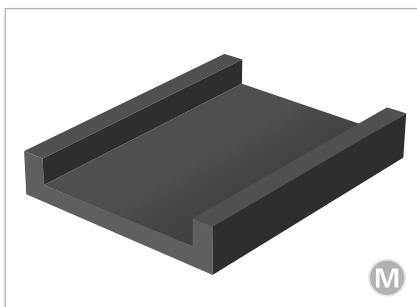

Habasit code	Material	Color	Packaging unit	Total length		Food grade
				m		
UD-70-PE05W-003+FG	PE05	white <input type="checkbox"/>	bar	3		•
UD-70-PE10B-003+RC	PE10	black <input checked="" type="checkbox"/>	bar	3		

UA-41 profile

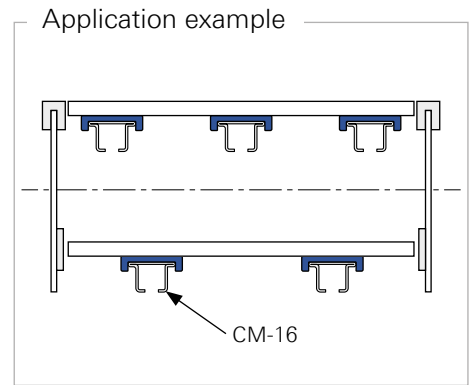
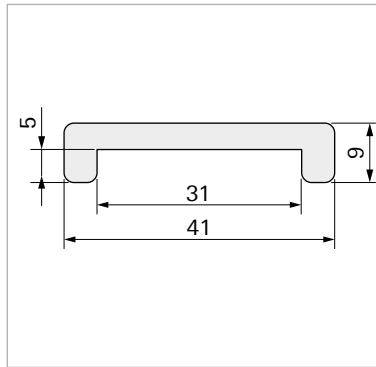
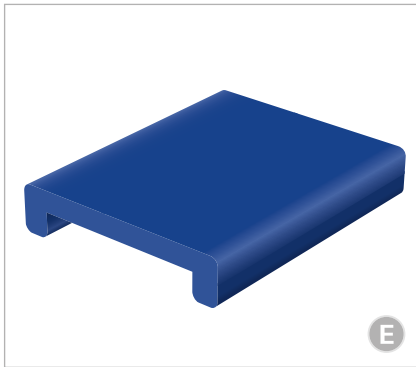

Habasit code	Material	Color	Packaging unit	Total length		Food grade
				m		
UA-41-PE10B-050+RC	PE10	black	coil	50		
UA-41-PE10B-003+RC	PE10	black	bar	3		
UA-41-PE10B-006+RC	PE10	black	bar	6		
UA-41-PE40G-050+FG	PE40	green	coil	50		•
UA-41-PE40G-003+FG	PE40	green	bar	3		•
UA-41-PE40G-006+FG	PE40	green	bar	6		•
UA-41-TP40C-050+FG	TP40	c-blue	coil	50		•
UA-41-TP40C-003+FG	TP40	c-blue	bar	3		•
UA-41-TP40C-006+FG	TP40	c-blue	bar	6		•

UB-41 profile

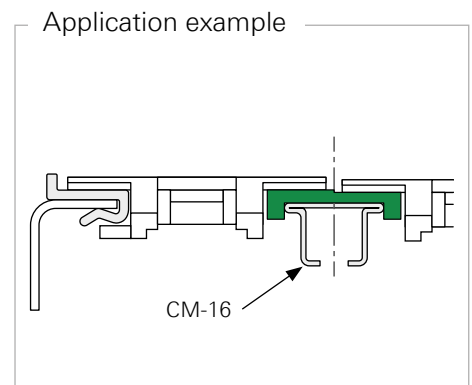
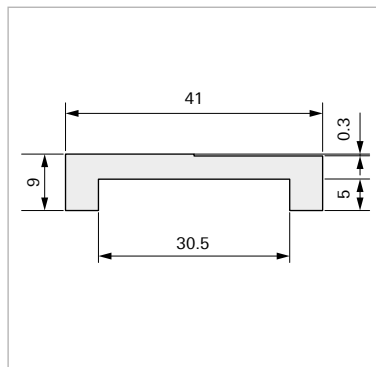
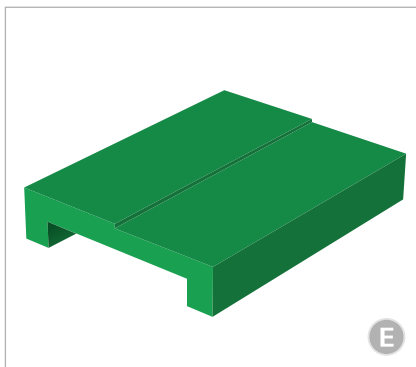

Habasit code	Material	Color	Packaging unit	Total length		Food grade
				m		
UB-41-PE10B-050+RC	PE10	black	coil	50		
UB-41-PE10B-006+RC	PE10	black	bar	6		
UB-41-PE40G-050+FG	PE40	green	coil	50		•

US-40 profile

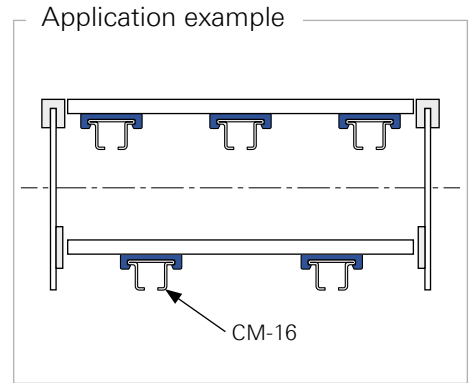
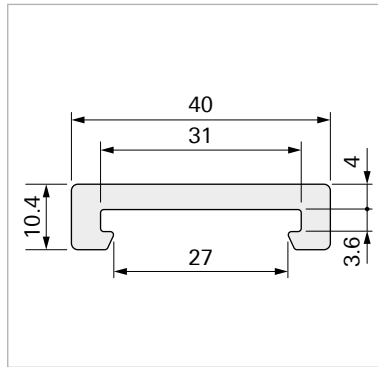
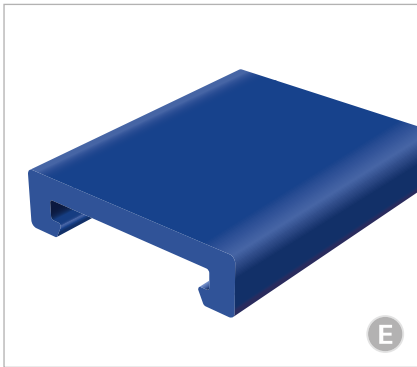

Habasit code	Material	Color	Packaging unit	Total length		Food grade
				m		
US-40-PE10B-003+RC	PE10	black	bar	3		
US-40-PE10B-006+RC	PE10	black	bar	6		
US-40-PE40W-003+FG	PE40	white	bar	3		•
US-40-PE40W-006+FG	PE40	white	bar	6		•
US-40-PE40G-003+FG	PE40	green	bar	3		•
US-40-PE40G-006+FG	PE40	green	bar	6		•
US-40-TP40C-003+FG	TP40	c-blue	bar	3		•
US-40-TP40C-006+FG	TP40	c-blue	bar	6		•

TA-40 profile

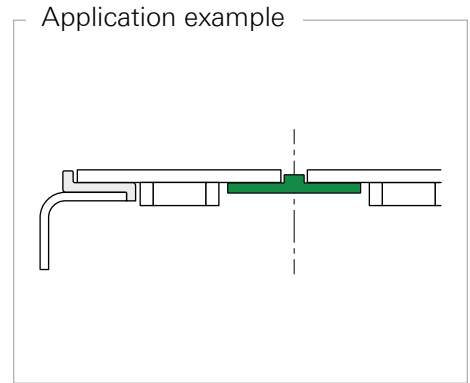
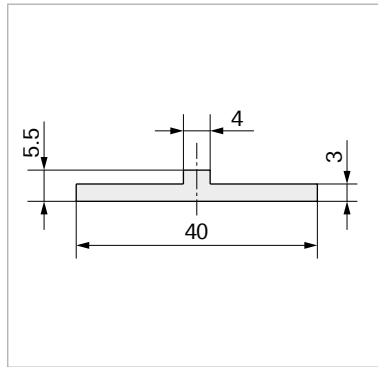
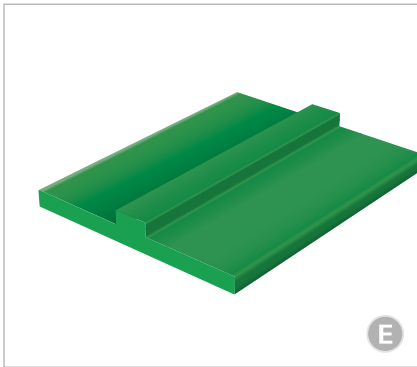

Habasit code	Material	Color	Packaging unit	Total length		Food grade
				m		
TA-40-PE40G-050+FG	PE40	green	coil	50		•

TU-43 profile

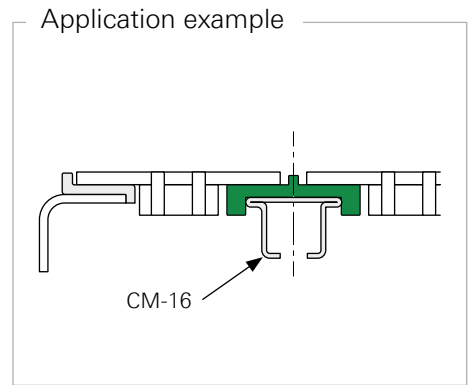
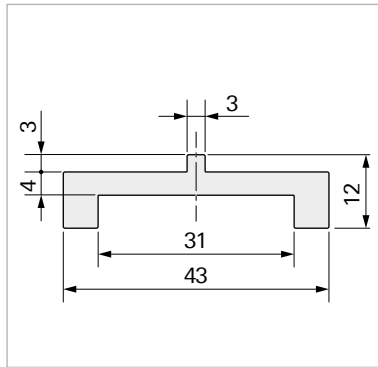
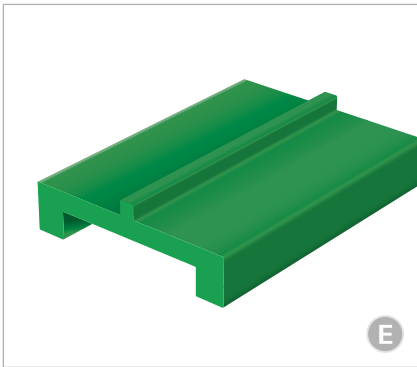

Habasit code	Material	Color	Packaging unit	Total length	Food grade
				m	
TU-43-PE40G-050+FG	PE40	green	coil	50	•

TS-43 profile

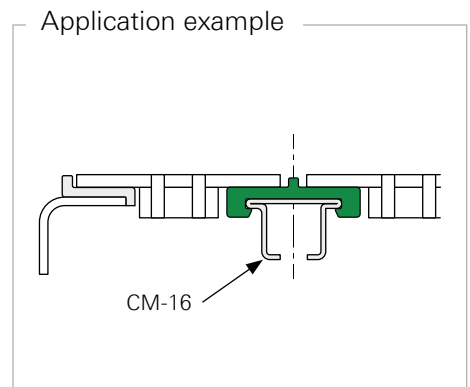
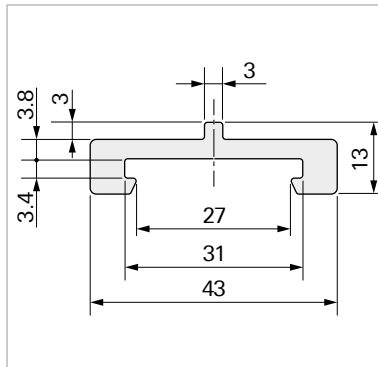
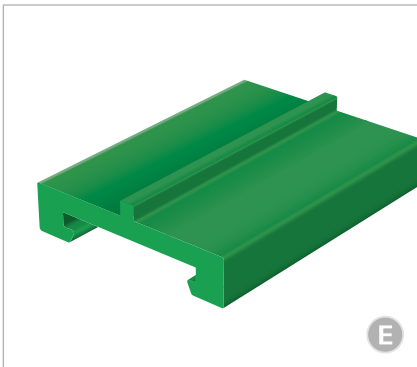

Habasit code	Material	Color	Packaging unit	Total length	Food grade
				m	
TS-43-PE40G-003+FG	PE40	green	bar	3	•
TS-43-PE40G-006+FG	PE40	green	bar	6	•

CA-40 profile

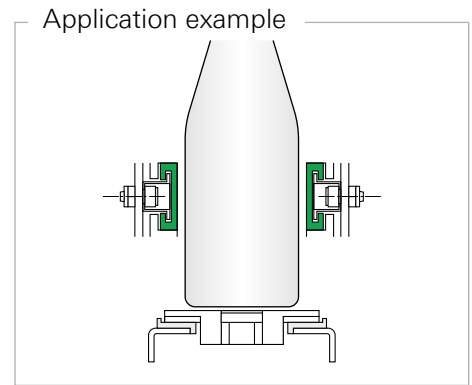
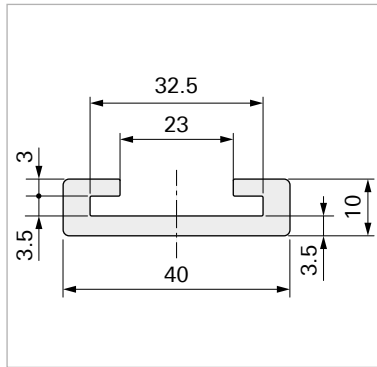
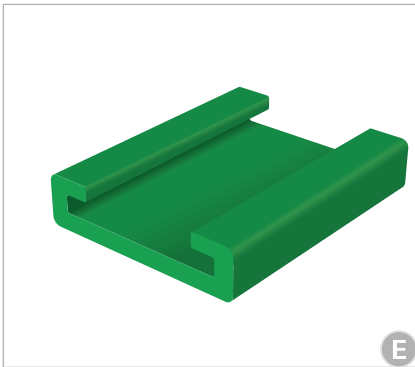

Habasit code	Material	Color	Packaging unit	Total length		Food grade
				m		
CA-40-PE10B-003+RC	PE10	black	bar	3		
CA-40-PE10B-006+RC	PE10	green	bar	6		
CA-40-PE40W-003+FG	PE40	white	bar	3		•
CA-40-PE40W-006+FG	PE40	white	bar	6		•
CA-40-PE40G-003+FG	PE40	green	bar	3		•
CA-40-PE40G-006+FG	PE40	green	bar	6		•
CA-40-TP40C-003+FG	TP40	c-blue	bar	3		•
CA-40-TP40C-006+FG	TP40	c-blue	bar	6		•

CA-50 profile

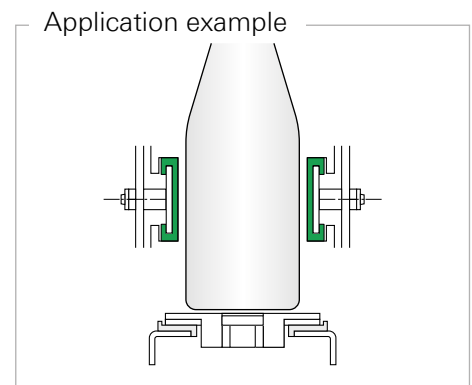
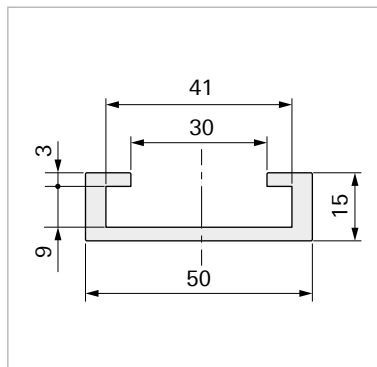
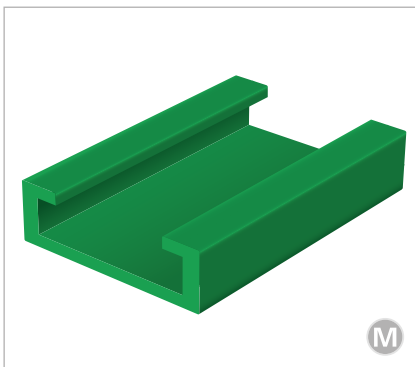

Habasit code	Material	Color	Packaging unit	Total length		Food grade
				m		
CA-50-PE10B-003+RC	PE10	black	bar	3		
CA-50-PE10G-003+RC	PE10	green	bar	3		
CA-50-PE05W-003+FG	PE05	white	bar	3		•

CA-60 profile

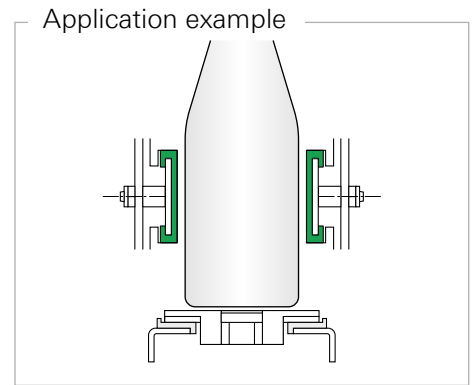
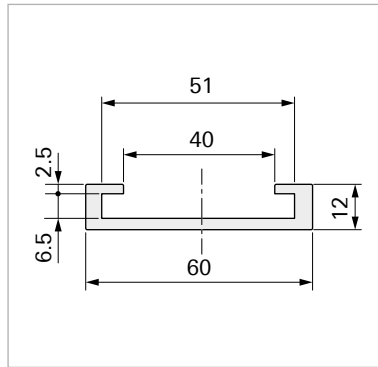
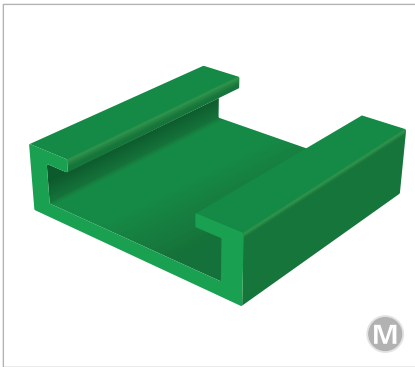

Habasit code	Material	Color	Packaging unit	Total length	Food grade
				m	
CA-60-PE10B-003+RC	PE10	black	bar	3	
CA-60-PE10G-003+RC	PE10	green	bar	3	
CA-60-PE05W-003+FG	PE05	white	bar	3	•

CA-81 profile

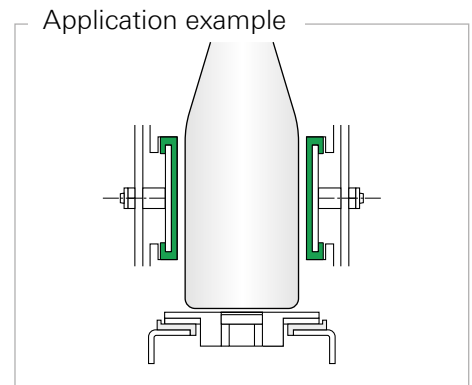
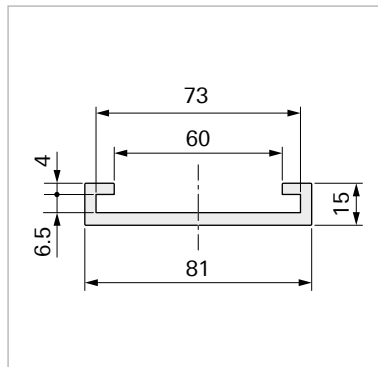
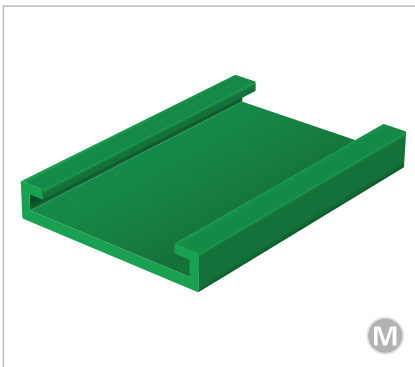

Habasit code	Material	Color	Packaging unit	Total length	Food grade
				m	
CA-81-PE10B-003+RC	PE10	black	bar	3	
CA-81-PE10G-003+RC	PE10	green	bar	3	
CA-81-PE05W-003+FG	PE05	white	bar	3	•

DG-78 profile

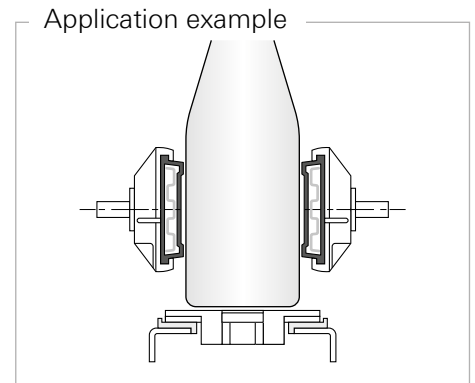
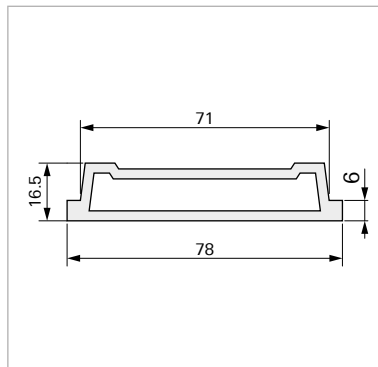

Habasit code	Material	Color	Packaging unit	Total length	
				m	
DG-78 PE03B-003	PE03	black	bar	3	

RA-18 profile

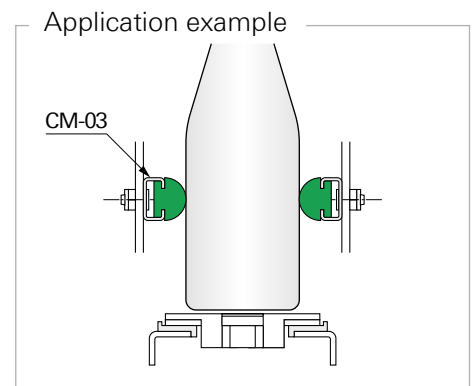
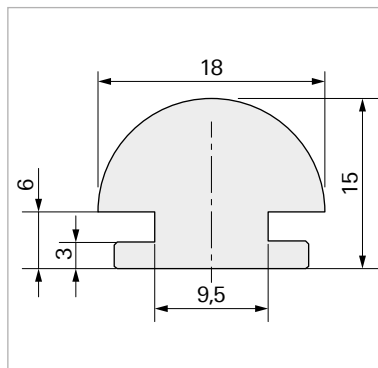
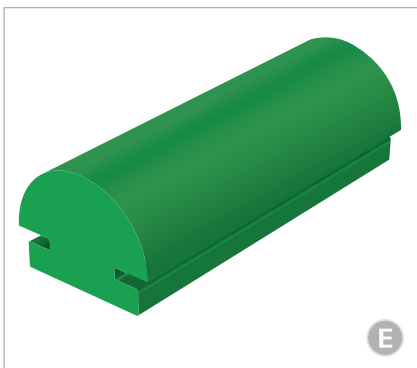

Habasit code	Material	Color	Packaging unit	Total length		Food grade
				m		
RA-18-PE40W-003+FG	PE40	white	bar	3		•
RA-18-PE40W-006+FG	PE40	white	bar	6		•
RA-18-PE40G-003+FG	PE40	green	bar	3		•
RA-18-PE40G-006+FG	PE40	green	bar	6		•

RR-17 profile

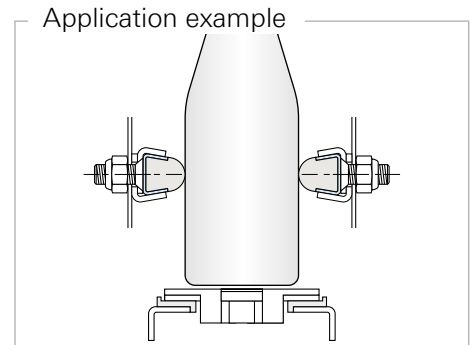
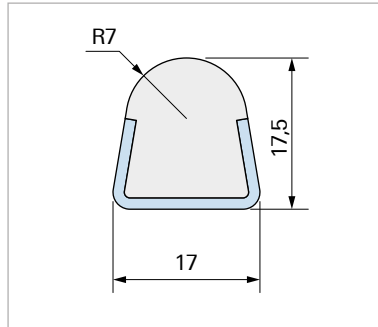
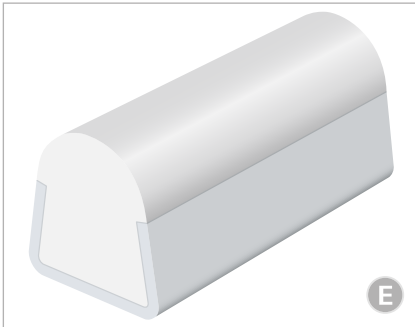

Habasit code	Material	Color	Assembled metal housing	Packaging unit	Total length	Food grade
					m	
RRV17-PE40W-003+FG	PE40	white <input type="checkbox"/>	AISI 304	bar	3	•
RRV17-PE40W-006+FG	PE40	white <input type="checkbox"/>	AISI 304	bar	6	•
RRW17-PE40W-003+FG	PE40	white <input type="checkbox"/>	AISI 430	bar	3	•

RS-17 profile

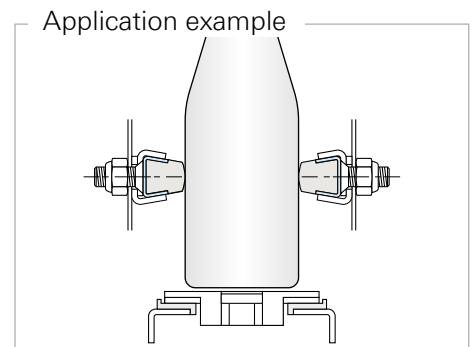
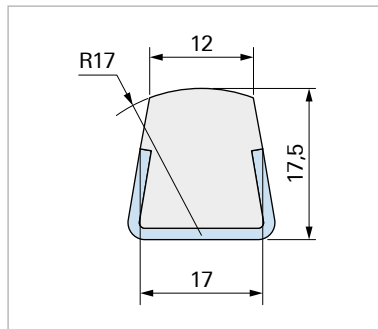
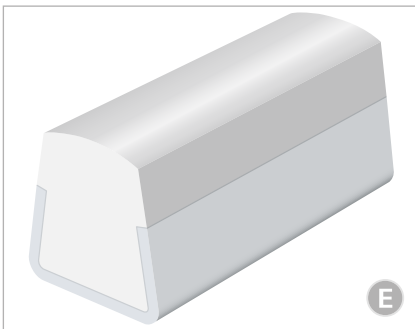

Habasit code	Material	Color	Assembled metal housing	Packaging unit	Total length	Food grade
					m	
RSV17-PE40W-003+FG	PE40	white <input type="checkbox"/>	AISI 304	bar	3	•

RF-17 profile

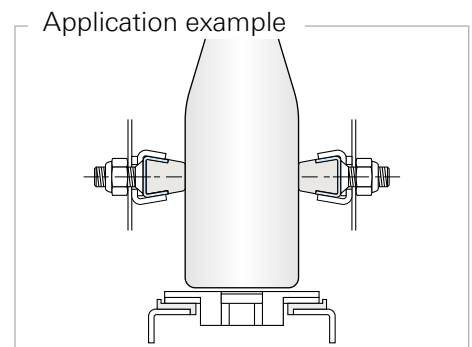
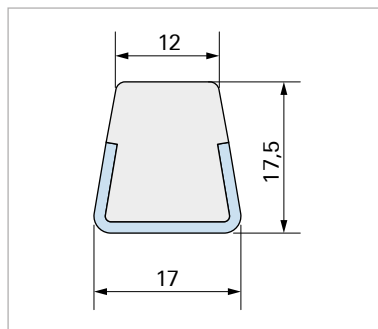
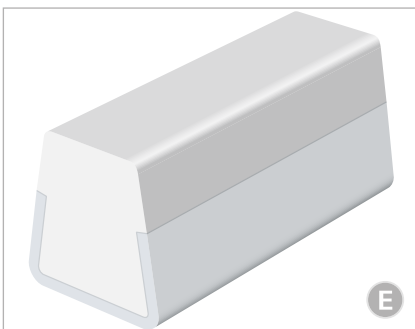

Habasit code	Material	Color	Assembled metal housing	Packaging unit	Total length	Food grade
					m	
RFV17-PE40W-003+FG	PE40	white <input type="checkbox"/>	AISI 304	bar	3	•

RI-17 profile

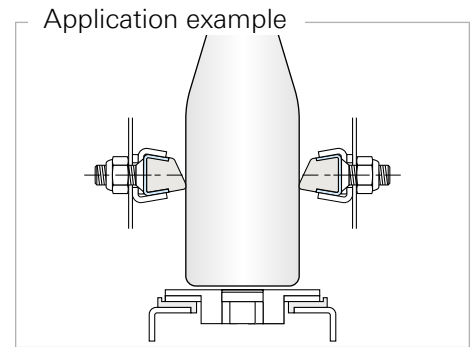
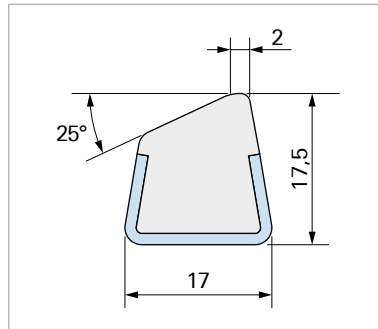
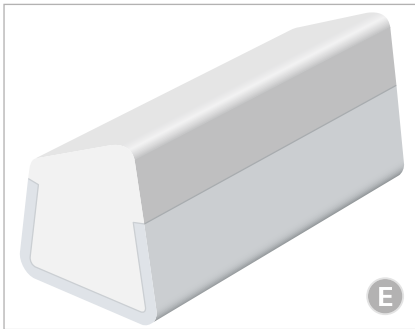

Habasit code	Material	Color	Assembled metal housing	Packaging unit	Total length	Food grade
					m	
RIV17-PE40W-003+FG	PE40	white <input type="checkbox"/>	AISI 304	bar	3	•

RT-32 profile

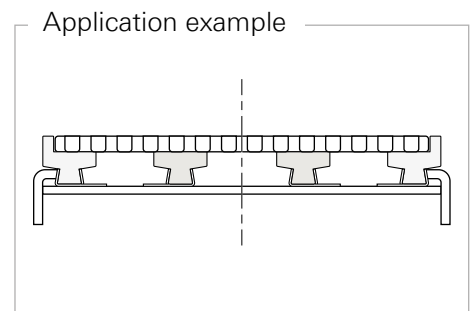
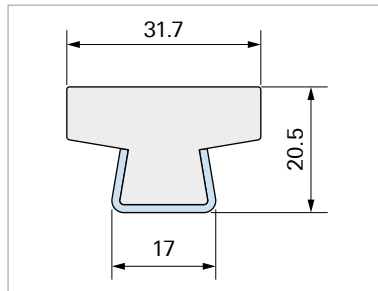
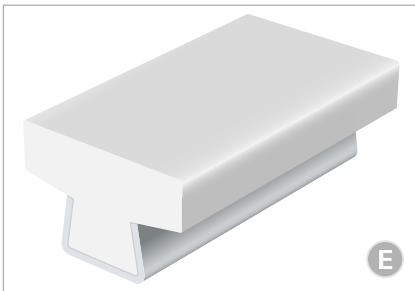

Habasit code	Material	Color	Assembled metal housing	Packaging unit	Total length	Food grade
					m	
RTV32-PE40W-003+FG	PE40	white <input type="checkbox"/>	AISI 304	bar	3	•
RTV32-PE40W-006+FG	PE40	white <input type="checkbox"/>	AISI 304	bar	6	•
RTW32-PE40W-003+FG	PE40	white <input type="checkbox"/>	AISI 430	bar	3	•
RTW32-PE40W-003+RC	PE40	white <input type="checkbox"/>	AISI 430	bar	6	•

RL-32 profile

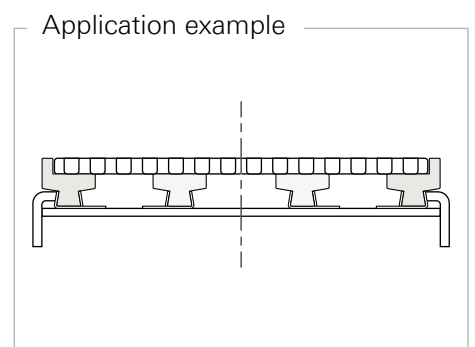
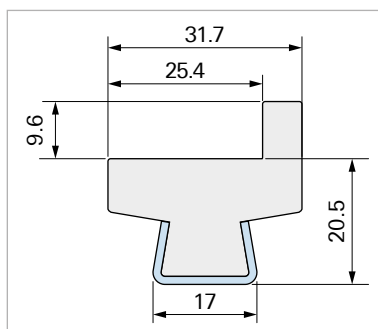
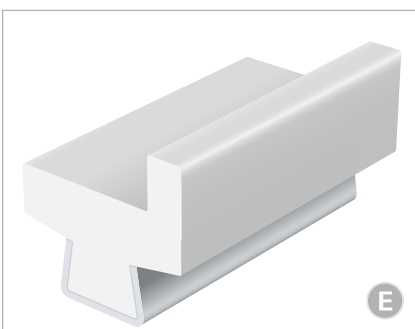

Habasit code	Material	Color	Assembled metal housing	Packaging unit	Total length	Food grade
					m	
RLV32-PE40W-003+FG	PE40	white <input type="checkbox"/>	AISI 304	bar	3	•
RLW32-PE40W-003+FG	PE40	white <input type="checkbox"/>	AISI 430	bar	3	•

PC profile

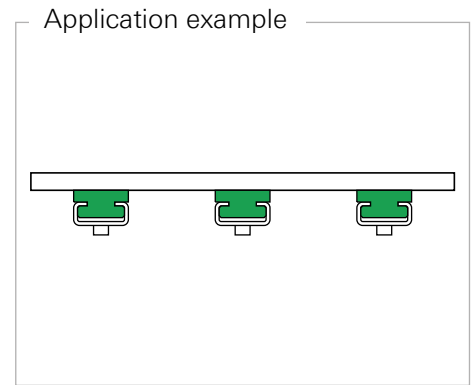
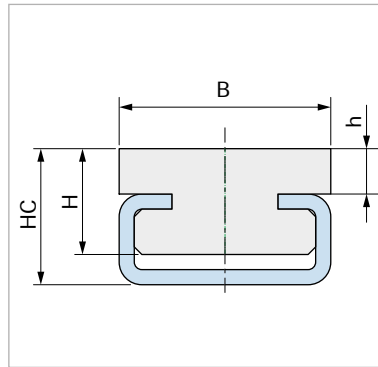
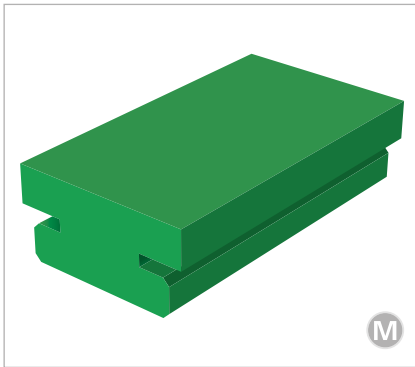

Habasit code	B	H	BC	HC	h	Material	suitable metal profile (not included)	Color	Packaging unit	Total length
	mm	mm	mm	mm	mm					m
PC-21-PE10G-003+RC	20	10	20	14	4	PE10	CM-03	green	bar	3
PC-23-PE10G-003+RC	20	15	20	17	7	PE10	CM-03	green	bar	3
PC-25-PE10G-003+RC	20	20	20	22	12	PE10	CM-03	green	bar	3
PC-31-PE10G-003+RC	28	10	28	15	3	PE10	CM-05	green	bar	3
PC-33-PE10G-003+RC	28	15	28	18	6	PE10	CM-05	green	bar	3
PC-35-PE10G-003+RC	28	20	28	24	12	PE10	CM-05	green	bar	3
PC-41-PE10G-003+RC	38	10	38	21	3	PE10	CM-09	green	bar	3
PC-43-PE10G-003+RC	38	15	38	24	6	PE10	CM-09	green	bar	3
PC-45-PE10G-003+RC	38	20	38	30	12	PE10	CM-09	green	bar	3

PA-21 profile

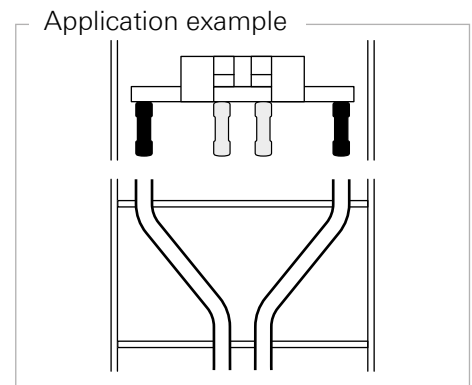
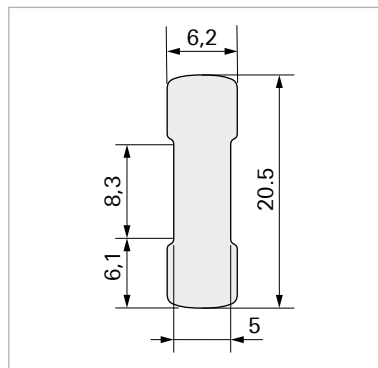

Habasit code	Material	Color	Packaging unit	Total length	Food grade
				m	
PA-21-PE10B-050+RC	PE10	black	coil	50	
PA-21-PE40W-050+FG	PE40	white	coil	50	•

UC-31 profile

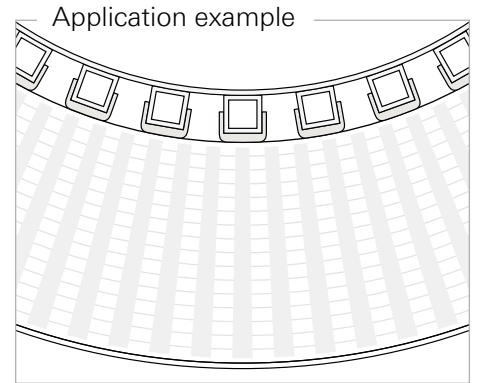
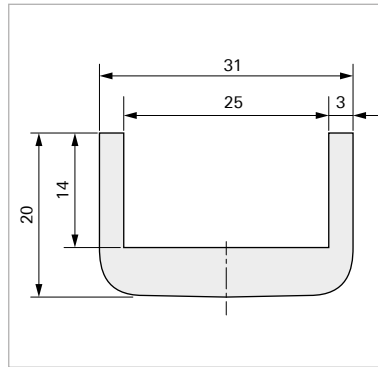
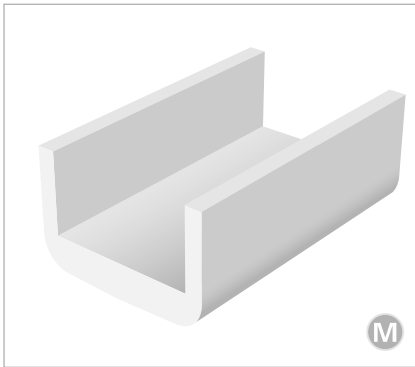

Habasit code	Material	Color	Packaging unit	Total length	Food grade
				m	
UC-31-PE40W-003+FG	PE40	white <input type="checkbox"/>	bar	3	•

PS-50 profile

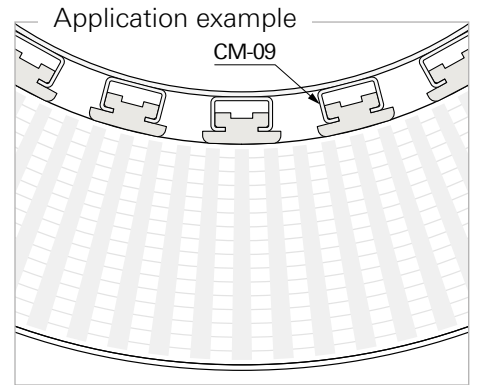
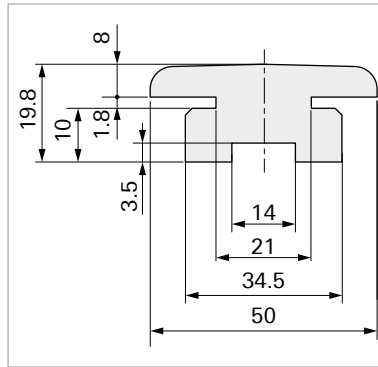

Habasit code	Material	Metal profile (not included)	Color	Packaging unit	Total length	Food grade
					m	
PS-50-PE40W-003+FG	PE40	CM-09	white <input type="checkbox"/>	bar	3	•

A Tapes

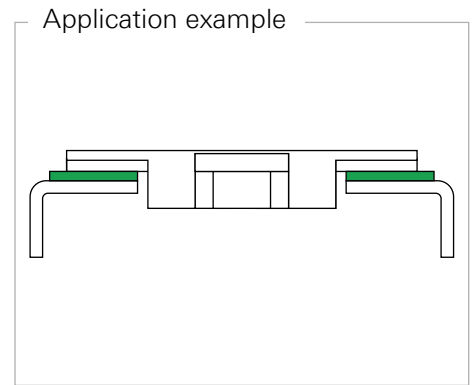
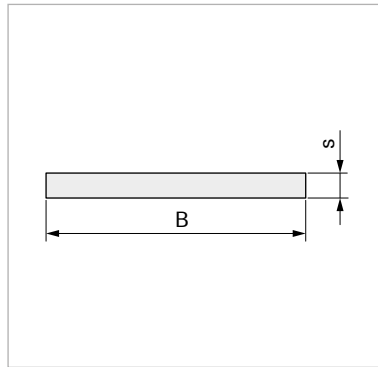

Habasit code	Material	B	s	Color	Packaging unit	Total length
		mm	mm			m
A2280-PE03G-050	PE03	280.0	2.0	green <input checked="" type="checkbox"/>	coil	50
A3260-PE03G-050	PE03	260.0	3.0	green <input checked="" type="checkbox"/>	coil	50
A4240-PE03G-050	PE03	240.0	4.0	green <input checked="" type="checkbox"/>	coil	50
A5220-PE03G-025	PE03	220.0	5.0	green <input checked="" type="checkbox"/>	coil	25

WS wearstrips

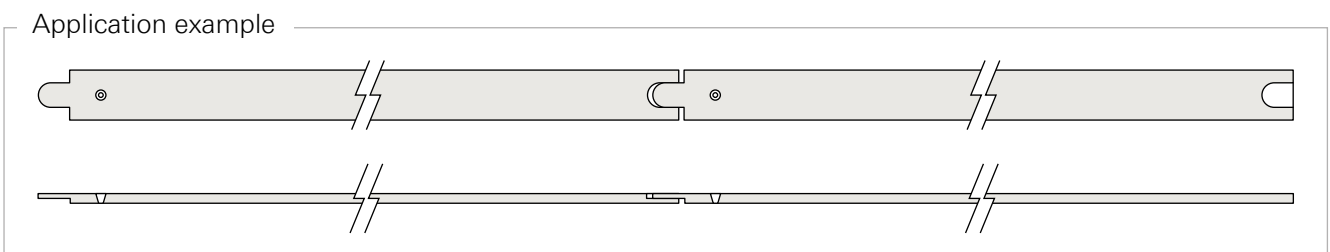
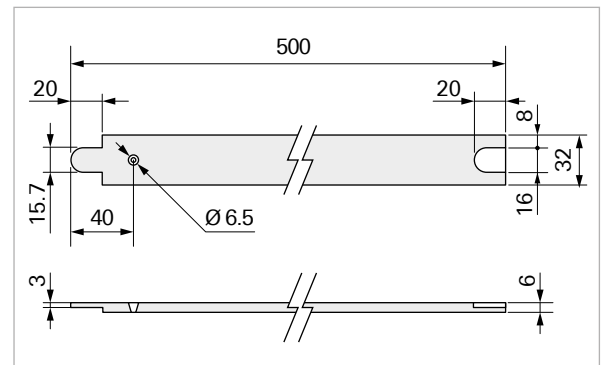
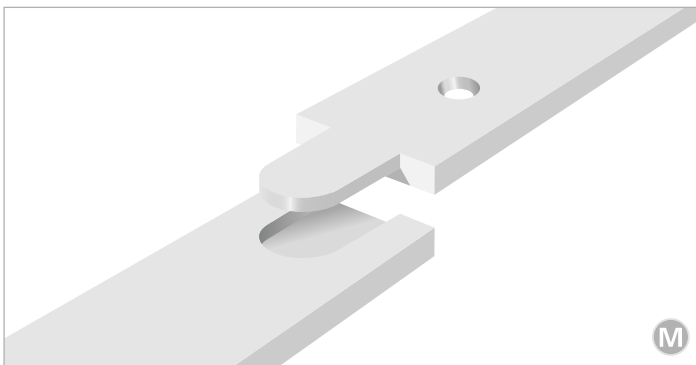

Habasit code	Description	Material	color	N° per box
WS-01-PE03W	Wear strip 01	PE03	white <input type="checkbox"/>	100
WSK01-PE03W	Wear strip Kit 01	PE03	white <input type="checkbox"/>	100
WSS01-PA6EW	Screw M6x30	PA6	white <input type="checkbox"/>	100
WSN01-POMCW	Nut M6	POM	white <input type="checkbox"/>	100

In addition to the extruded and machined profiles, Habiplast™ offers a complete range of corner and straight tracks, designed for the use with both plastic and metal chains.

Tab and Bevel tracks

For several years, Tab and Bevel tracks have been the most common solution to guide chains along the curved section of conveyors.

They still represent the most cost effective solution where the frequent conveyor cleaning and the stability of the product conveyed are not considered a top priority.

Tab and Bevel tracks are normally provided in UHMW Polyethylene. Other materials are available on request.

Magnetic Tracks

HabiPLAST™ magnetic corner tracks have been developed to allow easy and quick removal of the conveyor chain for frequent cleaning operations. At the same time, the tracks optimize chain retention along the curve.

The chain is held down by the force of magnetic poles. The number and position of the poles along the track are designed to maximize chain retention while minimizing the energy consumption required to move the chain.

HabiPLAST magnetic corner tracks are suitable for use with both plastic and metal chains.

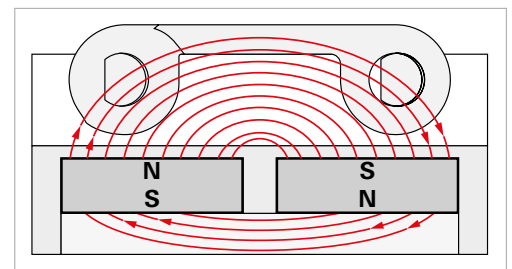

The recommended material combination for magnetic tracks is:

- TriboPlus cobalt blue TP40C for the carry lane
 - UHMW black polyethylene PE10B for the return lane
- TriboPlus is a new generation of specially lubricated polyethylene with outstanding tribological properties.

Compared to the standard high density polyethylene (UHMW-PE), laboratory tests have shown the following properties:

- Reduction of friction and power consumption of around 50%
- Almost total absence of wear
- Much higher load limit

Other materials are available on request.

Product properties	Your benefit
Lower friction	Energy savings
Less noise	Improved working conditions
Higher wear resistance	Less dusting and consequent higher level of hygiene
Higher speed and load limits	Higher productivity
Self-lubrication	Less maintenance
Longer life	Lower operational costs

Type	Advantages	Disadvantages
<ul style="list-style-type: none"> • Tab 	<ul style="list-style-type: none"> • Good holding retention • One piece return track 	<ul style="list-style-type: none"> • Chain edge will lift • Chain can not be removed from track • More noisy
<ul style="list-style-type: none"> • Bevel 	<ul style="list-style-type: none"> • Chain flat through Curve • Chain can be removed from straight section 	<ul style="list-style-type: none"> • Two pieces return track • Lack of mechanical retention
<ul style="list-style-type: none"> • Magnetic 	<ul style="list-style-type: none"> • Chain flat through Curve • Chain can be removed from straight and curve section 	<ul style="list-style-type: none"> • Thick return track • Lack of mechanical retention • More expensive

Installation

HabiPLAST™ magnetic tracks are supplied not assembled together with stainless steel assembly screws.

On request they can be provided with side holes or threaded inserts.

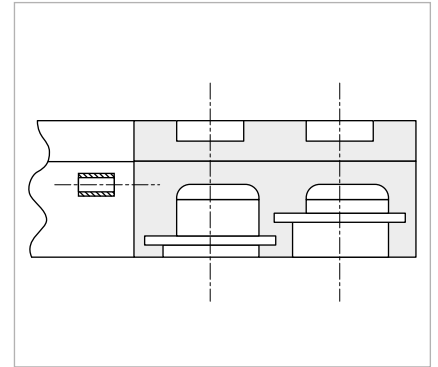
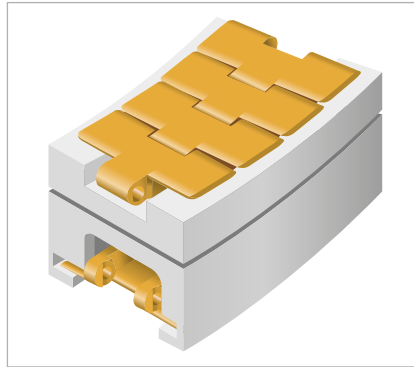

Accessories

Magnetic tracks are often used in combination with return guide shoes, that help the alignment of the chain to the return cavities of the tracks.

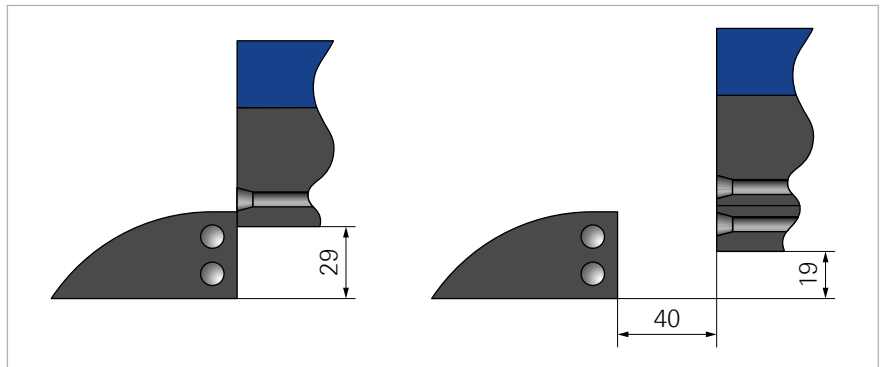

Code structure

POS 1	POS 2	POS 3-4	POS 5	POS 6	POS 7	POS 8-10	POS 11-12	POS 13	POS 14-15	POS 16	POS 17-18
T	E	16	D	T	T	- 90	- 1	T	- 0	0	- -
Type of track	Track series	Chain width*	Radius*	Lane type	Design	Angle (corner T)* Length (straight T)	Nr of lanes *	Material	Special radius	Tangents *	Special Features
T = Corner	B = C0770	16 = 3.25	C = 600	T = Top track	B = Bevel			T = TP40-C+FG		0 = No tangents	
S = Straight	E = C0880	23 = 4.50	D = 500	B = Bottom track (Magnetic)	T = Tab			R = PE10-B+RC		1 = 4" tangents both side	
	G = C0882	38 = 7.50	E = 650	or Bottom plate (Bevel)	M = Magnetic			U = PE40-W+FG		2 = 4" tangent infeed side	
	H = C1061	50 = 10.00	G = 750		S = Straight			N = PA6C-D+LF		3 = 4" tangent discharge side	
	I = C0800	60 = 12.00	H = 800					S = PE10-G+RC		4 = 50 mm tangent both side	
			I = 900					E = TP40-B+FE		5 = 50 mm tangent infeed side	
			J = 1000							6 = 50 mm tangent discharge side	
			M = 860							X = special tangents	
			R = 457 (18")								
			U = 610 (24")								

*: see Product Data Sheets for available materials, colors, dimensions and features.

Chain tracks

Magnetic Corner Tracks C0880 series

Chain Types: C0880M, C0881M.

Chain width: 3.25"/3.30", 4.50". (7.50" available on request).

Radii: 500 mm, 610 mm (24"). Centerline 1st lane

Angle: 30°, 45°, 60°, 90°

Standard materials:

T - TP40-C (Blue), carry track,

R - PE10-B (Black), carry + return track.

Standard lanes: 1 to 3. Lanes from 4 to 8 available on request.

Supplied as: Single track. For carry + return, order (A) + (B).

Part (A): Carry track, provided with assembled magnets.

Part (B): Return track, provided with stainless steel assembly screws.

Accessories on request: return shoes (see data sheet) and inserts.

Special configurations on request: tangents, special radii, special angles, mounting options. Other materials: PE40-W (Nat White), PA6C-D+LF (Grey).

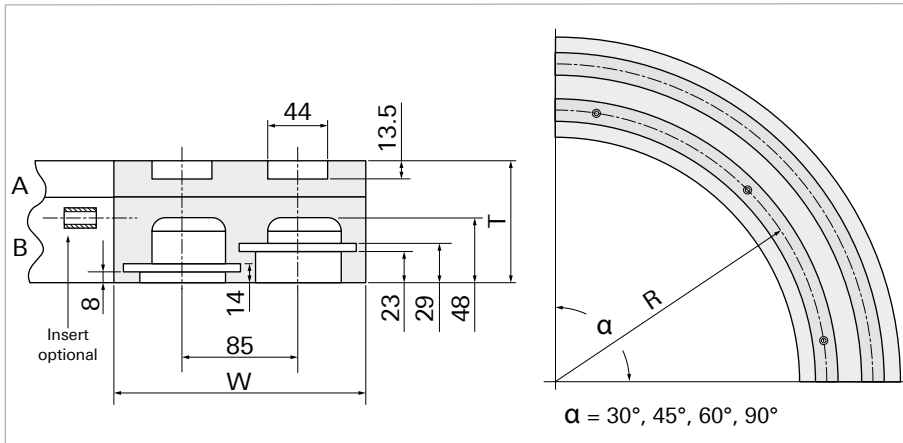
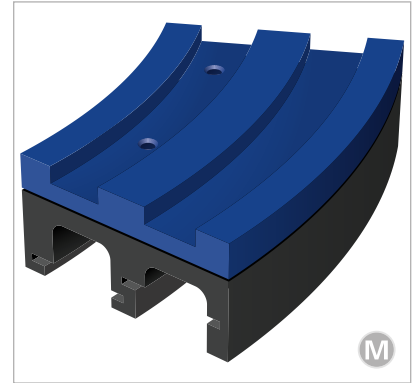

Application example



Data

Chain width	Lanes	Width W	Thickness T	Part	Radius 500 mm		Radius 610 mm (24")	
					TP40	PE10	TP40	PE10
3.25" / 3.30"	1	100	27	A	TE16DTM-##-1T-00	TE16DTM-##-1R-00	TE16UTM-##-1T-00	TE16UTM-##-1R-00
			55	B		TE16DBM-##-1R-00		TE16UBM-##-1R-00
	2	185	27	A	TE16DTM-##-2T-00	TE16DTM-##-2R-00	TE16UTM-##-2T-00	TE16UTM-##-2R-00
			63	B		TE16DBM-##-2R-00		TE16UBM-##-2R-00
	3	270	27	A	TE16DTM-##-3T-00	TE16DTM-##-3R-00	TE16UTM-##-3T-00	TE16UTM-##-3R-00
			63	B		TE16DBM-##-3R-00		TE16UBM-##-3R-00
4.50"	1	129	27	A	TE23DTM-##-1T-00	TE23DTM-##-1R-00	TE23UTM-##-1T-00	TE23UTM-##-1R-00
			55	B		TE23DBM-##-1R-00		TE23UBM-##-1R-00
	2	246	27	A	TE23DTM-##-2T-00	TE23DTM-##-2R-00	TE23UTM-##-2T-00	TE23UTM-##-2R-00
			63	B		TE23DBM-##-2R-00		TE23UBM-##-2R-00
	3	363	27	A	TE23DTM-##-3T-00	TE23DTM-##-3R-00	TE23UTM-##-3T-00	TE23UTM-##-3R-00
			63	B		TE23DBM-##-3R-00		TE23UBM-##-3R-00

Complete the product code by substituting ## with the chosen angle

Ex.: TE16DTM-90-1T-00 (90° corner track in TP40-C material).

Chain tracks

Magnetic Corner Tracks C1061 series

Chain Types: C1061M.

Chain width: 3.30".

Radii: 500 mm, 610 mm (24"). Centerline 1st lane.

Angle: 30°, 45°, 60°, 90°

Standard materials:

T - TP40-C (Blue), carry track,

R - PE10-B (Black), carry + return track.

Standard Lanes: 1 to 3. Lanes from 4 to 8 available on request.

Supplied as: Single track. For carry + return, order (A) + (B).

Part (A): Carry track, provided with assembled magnets.

Part (B): Return track, provided with stainless steel assembly screws.

Accessories on request: return shoes (see data sheet) and inserts.

Special configurations on request: tangents, special radii, special angles, mounting options. Other materials:

PE40-W (Nat White), PA6E-D+LF (Grey).

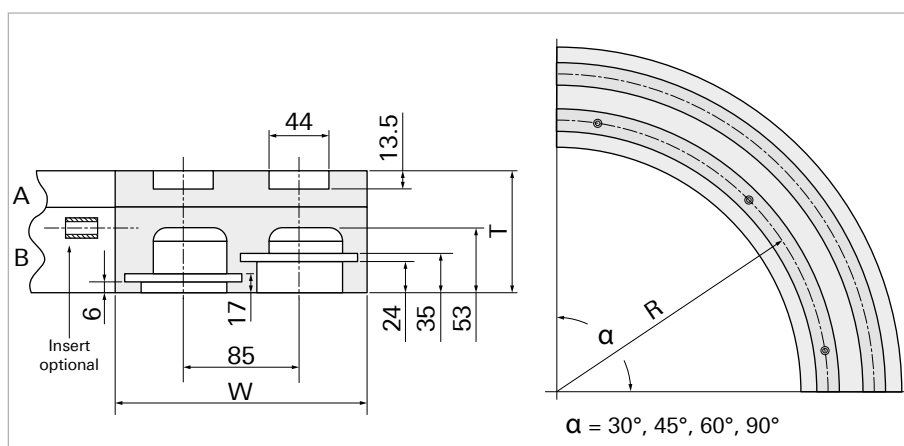
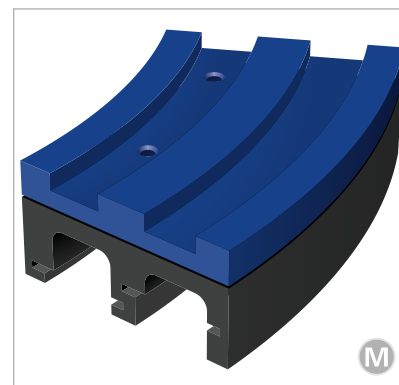

Application example



Data

Chain width	Lanes	Width W	Thickness T	Part	Radius 500 mm		Radius 610 mm (24")	
					TP40	PE10	TP40	PE10
3.25" / 3.30"	1	100	27	A	TH17DTM-##-1T-00	TH17DTM-##-1R-00	TH17UTM-##-1T-00	TH17UTM-##-1R-00
			55	B		TH17DBM-##-1R-00		TH17UBM-##-1R-00
	2	185	27	A	TH17DTM-##-2T-00	TH17DTM-##-2R-00	TH17UTM-##-2T-00	TH17UTM-##-2R-00
			63	B		TH17DBM-##-2R-00		TH17UBM-##-2R-00
	3	270	27	A	TH17DTM-##-3T-00	TH17DTM-##-3R-00	TH17UTM-##-3T-00	TH17UTM-##-3R-00
			63	B		TH17DBM-##-3R-00		TH17UBM-##-3R-00

Complete the product code by substituting ## with the chosen angle

Ex.: TH17DTM-**90**-1T-00 (90° corner track in TP40-C material).

Chain tracks

Tab Corner Tracks C0880 series

Chain Types: C0880T, C0879T, C1061T, C0881T & C8811T.

Also compatible: C0890T & C0770T.

Chain width: 3.25"/3.30", 4.50", 7.50"

Angle: 90°. Other angles on request.

Standard materials:

T - TP40-C (Blue),

R - PE10-B (Black).

Other materials on request: PE40-W (Nat White), PE05B (Black), PA6C-D+LF (Grey).

Lanes: 1, 2, 3. Additional lanes on request.

Supplied as: Single tracks. For carry + return, order 2 tracks.

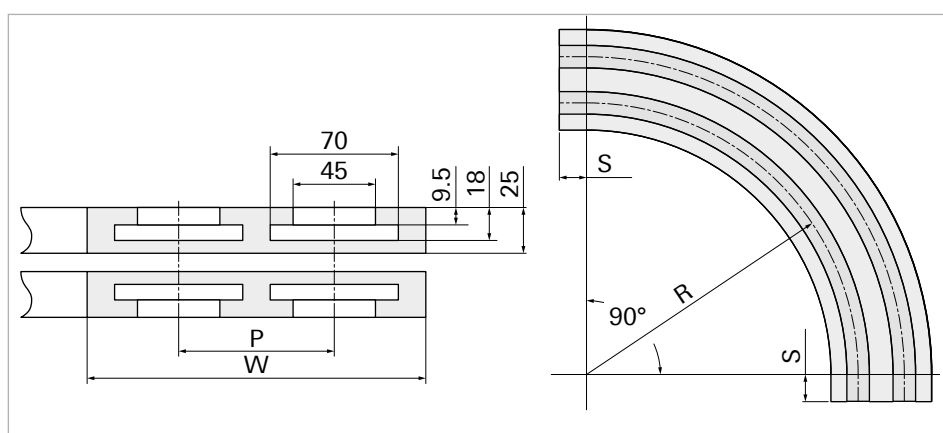
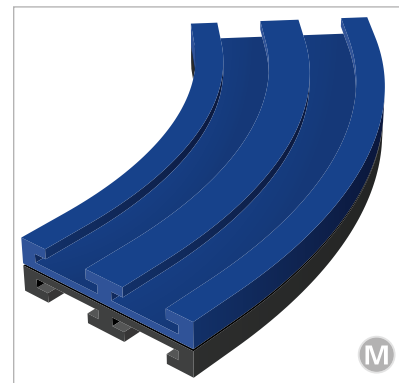

Data

Chain width	Lanes	Pitch P	Width W	Straight Tangents S	Radius R (Centreline 1st lane)			
					457 mm (18")*	500 mm	610 mm (24")	800 mm
3.25" 3.30"	1	-	100	-	TE16RTT-90-1#-00	-	TE16UTT-90-1#-00	-
	1	-	100	50	-	TE16DTT-90-1#-04	TE16UT-90-1#-04	-
	2	85	185	50	-	TE16DTT-90-2#-04	-	-
	3	85	270	50	-	TE16DTT-90-3#-04	-	-
4.50"	1	-	130	-	-	-	TE23UTT-90-1#-00	-
	1	-	130	50	-	-	TE23UTT-90-1#-04	TE23HTT-90-1#-04
	2	120	250	50	-	-	TE23UTT-90-2#-04	TE23HTT-90-2#-04
	3	120	370	50	-	-	TE23UTT-90-3#-04	-
7.50"	1	-	200	-	-	-	TE38UTT-90-1#-00	-
	1	-	200	50	-	-	TE38UTT-90-1#-04	TE38HTT-90-1#-04
	2	195	395	50	-	-	TE38UTT-90-2#-04	-
	3	195	590	50	-	-	TE38UTT-90-3#-04	-

Complete the product code by substituting # with the chosen material code
Ex.: TE23UTT-90-1**T**-00 (corner track in TP40-C Blue).

*not suitable for C1061T chain

Chain tracks

Tab Straight Tracks C0880 series

Chain Types: C0880T, C0879T, C1061T, C0881T & C8811T.

Also compatible: C0890T & C0770T.

Chain width: 3.25"/3.30", 4.50", 7.50".

Standard materials:

U - PE40-W (Nat White),

R - PE10-B (Black).

Other materials on request: TP40-C (Blue), PE05-B (Black).

Lanes: 1, Additional lanes on request.

Supplied as: Single lane. For carry + return, order 2 lines.

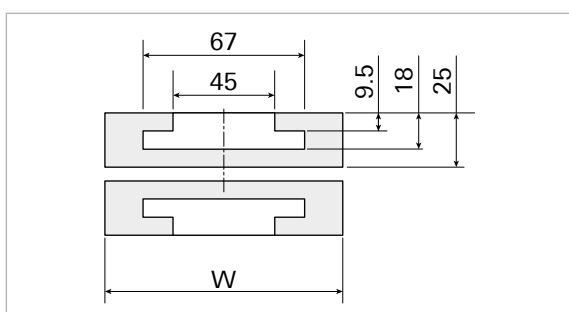
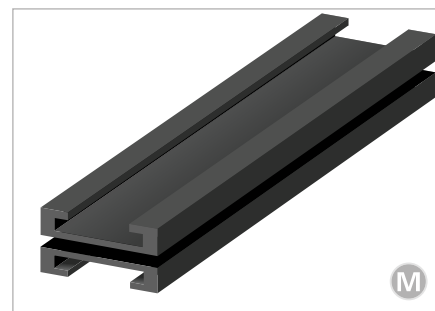

Application example

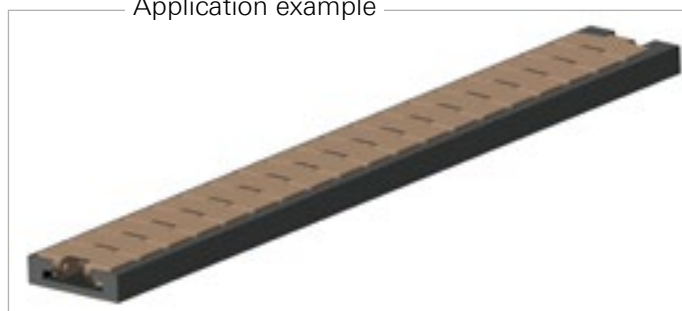

Data

Chain width	Lanes	Width W	Length 2m	Length 10ft
3.25"/3.30"	1	100	SE160TT200-1#-00	SE160TT305-1#-00
4.50"	1	130	SE230TT200-1#-00	SE230TT305-1#-00
7.50"	1	200	SE380TT200-1#-00	SE380TT305-1#-00

Complete the product code by substituting # with the chosen material code.

Ex.: SE160TT200-1**U**-00 (straight track in PE40-W)

Chain tracks

Tab Corner Tracks C0882 series

Chain Types: C0882T.

Chain width: 4.50", 7.50", 10", 12".

Angle: 90°. Other angles on request.

Standard materials:

T - TP40-C (Blue),

R - PE10-B (Black).

Other materials on request: PE40-W (Nat White),

PE05-B (Black), PA6C-D+LF (Grey).

Lanes: 1, 2, 3. Additional lanes on request.

Supplied as: single track.

For carry + return, order 2 tracks.

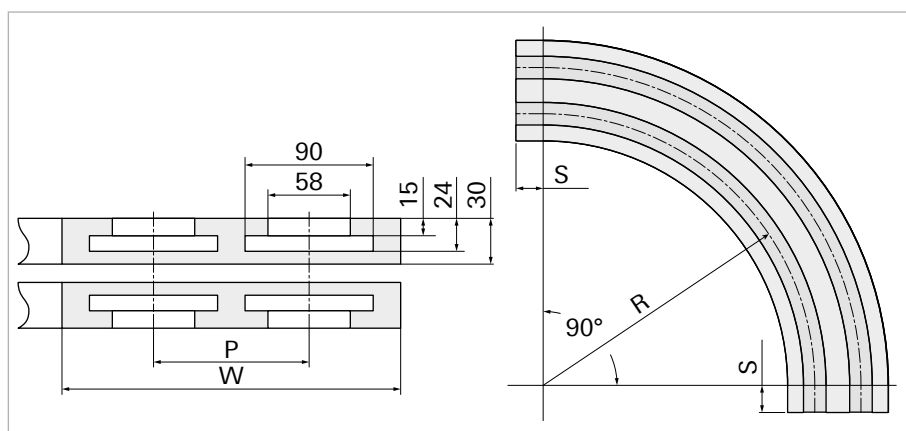
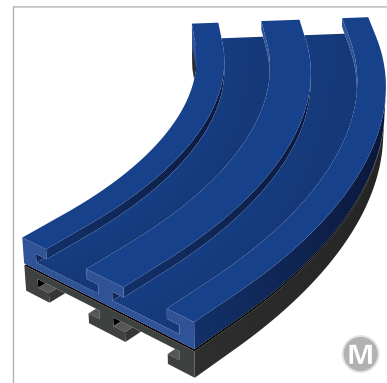

Application example



Data

Chain width	Lanes	Pitch P	Width W	Straight Tangents S	Radius R (Centreline 1st lane)			
					610 mm (24")	650 mm	800 mm	1000 mm
4.50"	1	-	130	-	TG23UTT-90-1#-00	-	-	-
	1	-	130	50	TG23UTT-90-1#-04	TG23ETT-90-1#-04	TG23HTT-90-1#-04	TG23JTT-90-1#-04
	2	120	250	50	TG23UTT-90-2#-04	-	-	-
	3	120	370	50	TG23UTT-90-3#-04	-	-	-
7.50"	1	-	200	-	TG38UTT-90-1#-00	-	-	-
	1	-	200	50	TG38UTT-90-1#-04	TG38ETT-90-1#-04	TG38HTT-90-1#-04	TG38JTT-90-1#-04
	2	195	395	50	TG38UTT-90-2#-04	-	-	-
	3	195	590	50	TG38UTT-90-3#-04	-	-	-
10"	1	-	270	-	TG50UTT-90-1#-00	-	-	-
	1	-	270	50	TG50UTT-90-1#-04	TG50ETT-90-1#-04	TG50HTT-90-1#-04	TG50JTT-90-1#-04
	2	260	530	50	TG50UTT-90-2#-04	-	-	-
	3	260	790	50	TG50UTT-90-3#-04	-	-	-
12"	1	-	320	-	TG60UTT-90-1#-00	-	-	-
	1	-	320	50	TG60UTT-90-1#-04	TG60ETT-90-1#-04	TG60HTT-90-1#-04	TG60JTT-90-1#-04
	2	310	630	50	TG60UTT-90-2#-04	-	-	-
	3	310	940	50	TG60UTT-90-3#-04	-	-	-

Complete the product code by substituting # with the chosen material code
 Ex.: TG23UTT-90-1**T**-00 (corner track in TP40-C).

Chain tracks

Tab Straight Tracks C0882 series

Chain Types: C0882T.

Chain width: 4.50", 7.50", 10", 12".

Standard materials:

U - PE40-W (Nat White),

R - PE10-B (Black).

Other materials on request: TP40-C (Blue), PE05-B (Black)

Lanes: 1, Additional lanes on request.

Supplied as: Single lane. For carry + return, order 2 lines.

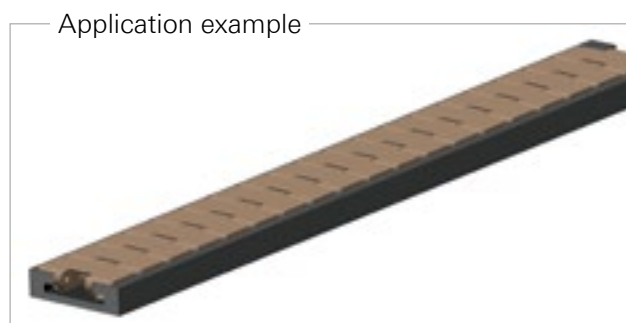
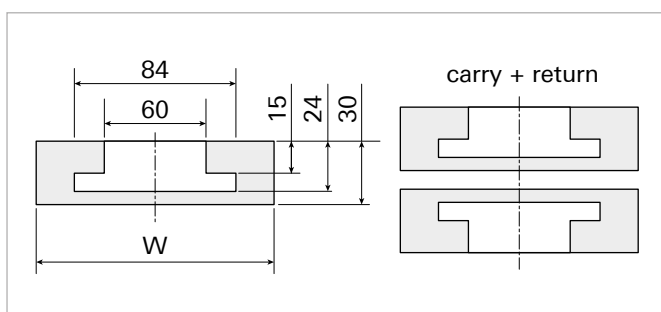
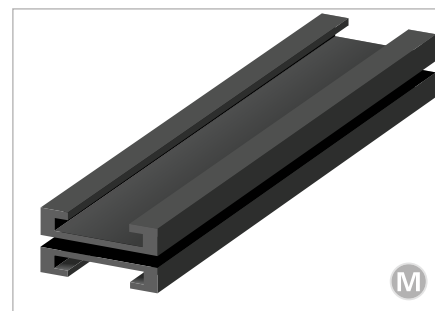

Data

Chain width	Lanes	Width W	Length 2m	Length 10ft
4.50"	1	130	SG230TT200-1#-00	SG230TT305-1#-00
7.50"	1	200	SG380TT200-1#-00	SG380TT305-1#-00
10"	1	270	SG500TT200-1#-00	SG500TT305-1#-00
12"	1	320	SG600TT200-1#-00	-

Complete the product code by substituting # with the chosen material code

Ex.: SG230TT200-1**U**-00 (straight track in PE40-W).

Chain tracks

Bevel Corner Tracks C0880 series

Chain Types: C0880B,C0879B,C1071B, C0881B & C8811B.

Chain width: 3.25"/3.30",4.50",7.50".

Angle: 90°. Other angles on request.

Standard materials:

T - TP40-C (Blue) chain track,

R - PE10-B (Black) chain track + support plate.

Other materials on request: PE40-W(Nat White),

PE05-B(Black), PA6C-D+LF (Grey).

Lanes: 1, 2, 3. Additional lanes on request.

Supplied as: Single track. Part (A): Chain track, Part (B): Support plate.

For carry + return, order 2 x (A) and 1 x (B).

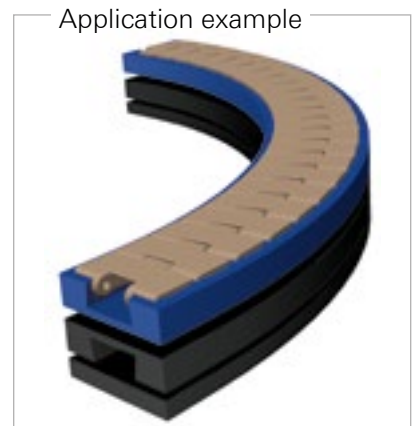
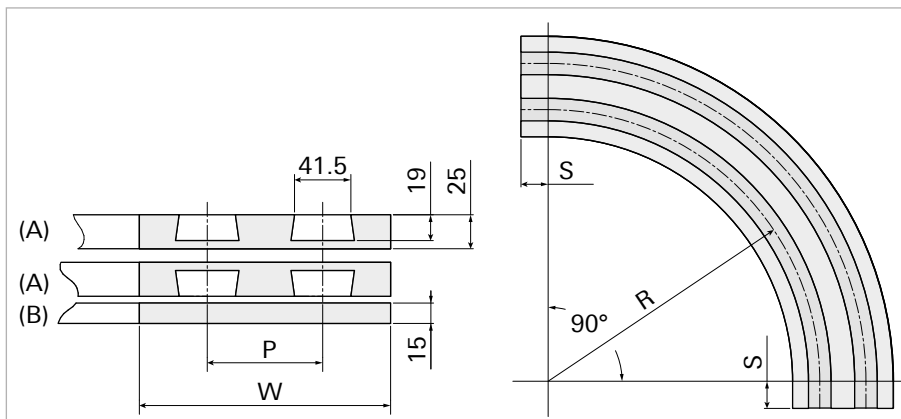
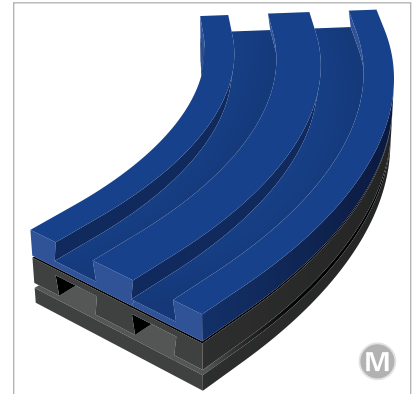

Data

Chain width	Lanes	Pitch P	Width W	Straight Tangents S	Part	Radius R (Centreline 1st lane)			
						457 mm (18")	500 mm	610 mm (24")	800 mm
3.25" 3.30"	1	-	100	-	A	TE16RTB-90-1#-00	-	TE16UTB-90-1#-00	-
				-	B	TE16RBB-90-1R-00	-	TE16UBB-90-1R-00	-
	2	85	185	50	A	-	TE16DTB-90-1#-04	TE16UTB-90-1#-04	-
				-	B	TE16DBB-90-1R-04	TE16UBB-90-1R-04	-	
				-	A	TE16DTB-90-2#-04	-	-	
				-	B	TE16DBB-90-2R-04	-	-	
3	85	270	50	A	TE16DTB-90-3#-04	-	-	-	
			-	B	TE16DBB-90-3R-04	-	-	-	
4.50"	1	-	130	-	A	-	-	TE23UTB-90-1#-00	-
				-	B	-	-	TE23UBB-90-1R-00	-
	2	120	250	50	A	-	-	TE23UTB-90-1#-04	TE23HTB-90-1#-04
				-	B	-	-	TE23UBB-90-1R-04	TE23HBB-90-1R-04
				-	A	TE23UTB-90-2#-04	TE23HTB-90-2#-04	-	
				-	B	TE23UBB-90-2R-04	TE23HBB-90-2R-04	-	
3	120	370	50	A	-	-	TE23UTB-90-3#-04	-	
			-	B	-	-	TE23UBB-90-3R-04	-	
7.50"	1	-	200	-	A	-	-	TE38UTB-90-1#-00	-
				-	B	-	-	TE38UBB-90-1R-00	-
	2	195	395	50	A	-	-	TE38UTB-90-1#-04	TE38HTB-90-1#-04
				-	B	-	-	TE38UBB-90-1R-04	TE38HBB-90-1R-04
				-	A	TE38UTB-90-2#-04	-	-	
				-	B	TE38UBB-90-2R-04	-	-	
3	195	590	50	A	-	-	TE38UTB-90-3#-04	-	
			-	B	-	-	TE38UBB-90-3R-04	-	

Complete the product code by substituting # with the chosen material code
 Ex.: TE23UTB-90-1**T**-00 (corner track in TP40-C).

Chain tracks

Bevel Straight Tracks C0880 series

Chain Types: C0880B,C0879B,C1071B, C0881B & C8811B.

Also compatible with C0820, C0828, C0831.

Chain width: 3.25"/3.30",4.50",7.50".

Standard materials:

U - PE40-W (Nat White),

R - PE10-B (Black).

Other materials on request: TP40-C (Blue), PE05-B(Black).

Lanes: 1, Additional lanes on request.

Supplied as: Single lane. Part (A): chain track, Part (B): support plate

For carry + return, order 2 x (A) and 1 x (B).

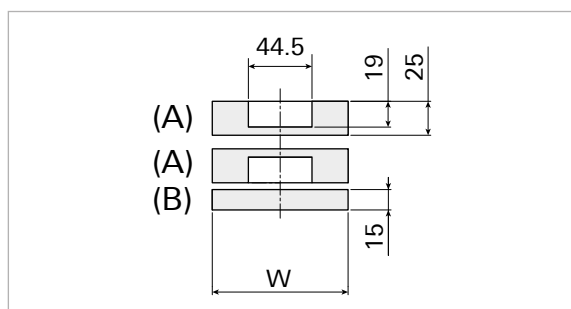
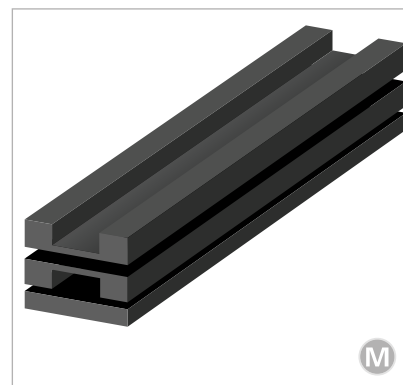

Application example

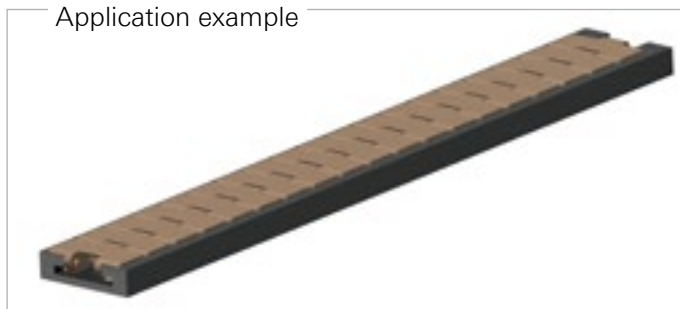

Data

Part	Chain width	Lanes	Width W	Length 2m	Length 10ft
A	3.25"/3.30"	1	100	SE160TB200-1#-00	SE160TB305-1#-00
	4.50"	1	130	SE230TB200-1#-00	SE230TB305-1#-00
	7.50"	1	200	SE380TB200-1#-00	SE380TB305-1#-00
B	3.25"/3.30"	1	100	SE160BB200-1#-00	SE160BB305-1#-00
	4.50"	1	130	SE230BB200-1#-00	SE230BB305-1#-00
	7.50"	1	200	SE380BB200-1#-00	SE380BB305-1#-00

Complete the product code by substituting # with the chosen material code

Ex.: SE160TB200-1**U**-00 (corner track in PE40-W).

Chain tracks

Bevel Corner Tracks C0882 series

Chain Types: C0882B.

Chain width: 4.50", 7.50", 10".

Angle: 90°. Other angles on request.

Standard materials:

T - TP40-C (Blue) chain track,

R - PE10-B (Black) chain track + support plate.

Other materials on request: PE40-W (Nat White),

PE05-B (Black), PA6C-D+LF (Grey).

Lanes: 1, 2, 3. Additional lanes on request.

Supplied as: Single track. Part (A): Chain track; Part (B): Support plate;

For carry + return, order 2 x (A) and 1 x (B), exception see (*).

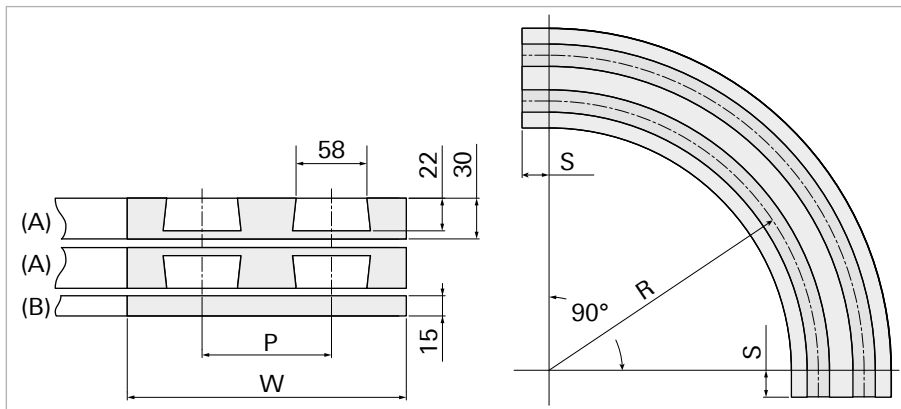
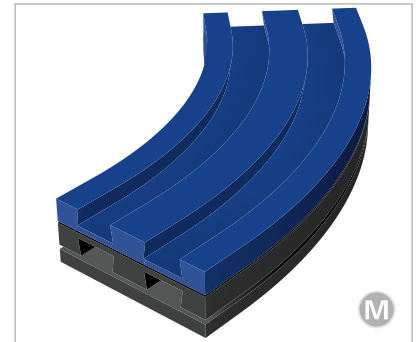

Application example

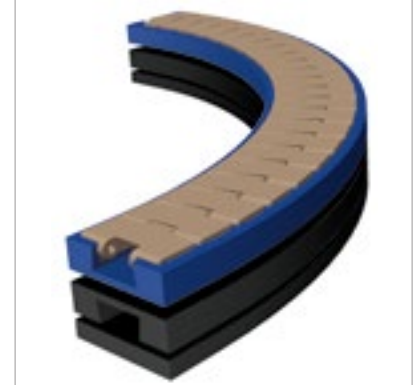

Data

Chain width	Lanes	Pitch P	Width W	Straight Tangents S	Part	Radius R (Centreline 1st lane)			
						610 mm (24")	650 mm	800 mm	1000 mm
4.50"	1	-	130	-	A	TG23UTB-90-1#-00	-	-	-
				-	B	TG23UBB-90-1R-00	-	-	-
	2	120	250	50	A	TG23UTB-90-1#-04	TG23ETB-90-1#-04	TG23HTB-90-1#-04	TG23JTB-90-1#-04
				50	B	TG23UBB-90-1R-04	TG23EBB-90-1R-04	TG23HBB-90-1R-04	TG23JBB-90-1R-04
				50	A	TG23UTB-90-2#-04	-	-	-
				50	B	TG23UBB-90-2R-04	-	-	-
3	120	370	50	A	TG23UTB-90-3#-04	-	-	-	
			50	B	TG23UBB-90-3R-04	-	-	-	
7.50"	1	-	200	-	A	TG38UTB-90-1#-00	-	-	-
				-	B	TG38UBB-90-1R-00	-	-	-
	2	195	395	50	A	TG38UTB-90-1#-04	TG38ETB-90-1#-04	TG38HTB-90-1#-04	TG38JTB-90-1#-04
				50	B	TG38UBB-90-1R-04	TG38EBB-90-1R-04	TG38HBB-90-1R-04	TG38JBB-90-1R-04
				50	A	TG38UTB-90-2#-04	-	-	-
				50	B	TG38UBB-90-2R-04	-	-	-
3	195	590	50	A	TG38UTB-90-3#-04	-	-	-	
			50	B	TG38UBB-90-3R-04	-	-	-	
10"	1	-	270	-	A	TG50UTB-90-1#-00	-	-	-
				-	B	TG50UBB-90-1R-00	-	-	-
	2	260	530	50	A	TG50UTB-90-1#-04	TG50ETB-90-1#-04	TG50HTB-90-1#-04	TG50JTB-90-1#-04
				50	B	TG50UBB-90-1R-04	TG50EBB-90-1R-04	TG50HBB-90-1R-04	TG50JBB-90-1R-04
				50	A	TG50UTB-90-2#-04	-	-	-
				50	B	TG50UBB-90-2R-04	-	-	-
3(*)	260	790	50	A (*)	TG50UTB-45-3#-04	-	-	-	
			50	B (*)	TG50UBB-45-3R-04	-	-	-	

(*) For 90°, 10" 3-lanes chain tracks order 4 times the 45° single chain track (A) and 2 times the 45° support plate (B). Complete the product code by substituting # with the chosen material code
 Ex.: TG23UTB-90-1**T**-00 (corner track in TP40-C Blue).

Chain tracks

Bevel Straight Tracks C0882 series

Chain Types: C0882B.

Chain width: 4.50", 7.50", 10".

Standard materials:

U - PE40-W (Nat White),

R - PE10-B (Black).

Other materials on request: TP40-C (Blue),

PE05-B (Black).

Lanes: 1, Additional lanes on request.

Supplied as: Single lane

Part (A): chain track

Part (B): support plate

For carry + return, order 2 x (A) and 1 x (B).

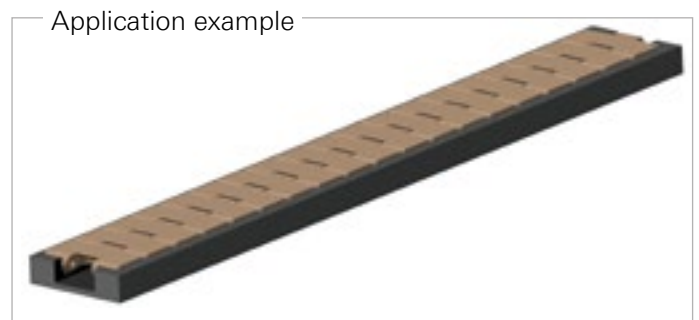
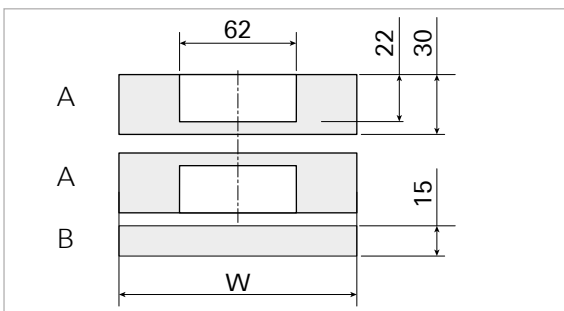
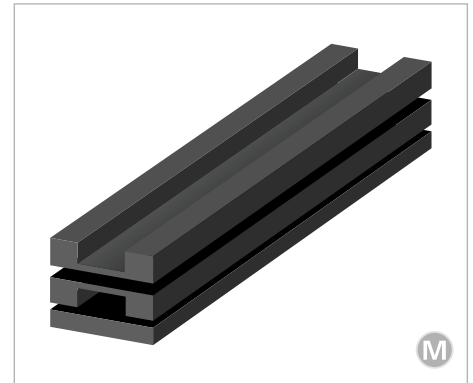

Data

Part	Chain width	Lanes	Width W	Length 2m	Length 10ft
A	4.50"	1	130	SG230TB200-1#-00	SG230TB305-1#-00
	7.50"	1	200	SG380TB200-1#-00	SG380TB305-1#-00
	10"	1	270	SG500TB200-1#-00	SG500TB305-1#-00
B	4.50"	1	130	SG230BB200-1#-00	SG230BB305-1#-00
	7.50"	1	200	SG380BB200-1#-00	SG380BB305-1#-00
	10"	1	270	SG500BB200-1#-00	SG500BB305-1#-00

Complete the product code by substituting # with the chosen material code

Ex.: SG230TB200-1**U**-00 (corner track in PE40-W).

Guides for timing belts

HabaSYNC® timing belts support conveying and linear movement applications where optimum performance requires precise product placement and component positioning. High-quality materials coupled with our state-of-the-art manufacturing process and years of experience ensure innovative solutions tailored to your needs. HabiPLAST™ timing belt support guides are designed to allow timing belts to run smoothly across a low-friction surface.

Our guides are manufactured in Ultra High Molecular Weight Polyethylene, which offers the following advantages:

- high chemical resistance
- corrosion resistance
- wear resistance
- low noise.

The product range fits standard HabaSYNC® belt widths and can be supplied with or without metallic profiles.

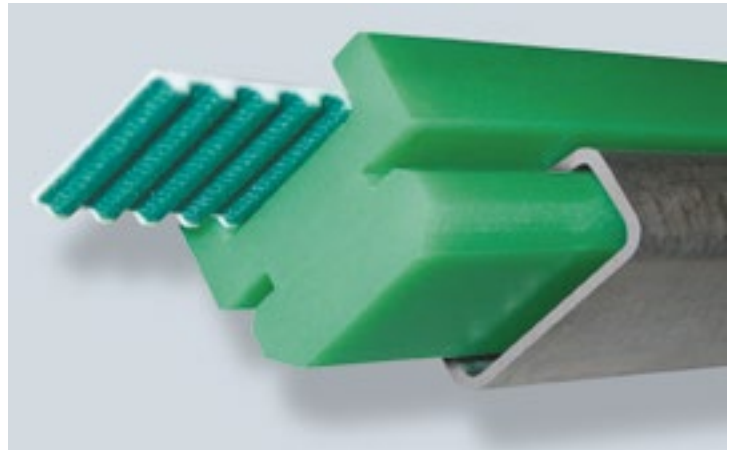

Guides for round belts, V-belts and roller chains

HabiPLAST™ profiles are the best solution for improving performances and reducing maintenance of V-belts, round belts, and roller chains.

- Excellent sliding of the chain/belt
- Great wear resistance
- Low coefficient of friction (less drive energy required)
- Low noise
- Good resistance to impacts also at low temperature
- High chemical resistance
- Easy and quick assembly
- Corrosion resistance



The standard material for guide profiles is HabiPLAST™ PE10 UHMW Polyethylene, green color. Other materials are available on request. Habasit offers a full range of standard guides and can produce any kind of profile according to customer's specifications.



Code structure

POS 1-2	POS 3	POS 4-5	POS 6	POS 7-10	POS 11	POS 12	POS 13-15	POS 16	POS 17-18			
T	1	-	1	5	-	P E 1 0	G	-	0 0 3	+	R	C
Product series (profile type)	Reference of the "CM" type suitable metal profile	Drawing identification (it identifies the belt/chain reference or the profile dimension).	-	Material	Color	-	Dimension (meters)	+	Special features			
	C = CM-03 E = CM-05 J = CM-09 K = CM-10 M = CM-11 P = CM-14/CM-15			PE03 - PE05 PE10 - PE40 PE80 - TP40 PA6E - PA6C PA66 POMC PP00 PTFE PVC0 PETC	B = black W = nat. white G = green C = cobalt blue T = blue D = grey Y = yellow R = red A = orange N = brown			FG = food grade EC = conductive FE = food grade + conductive RC = recycled RK = recycled confetti structure LF = low friction MO = MoS2 AR = antistatic recycled G1 = Glass fiber reinforced 10% G2 = Glass fiber reinforced 5% (US 13%) G3 = Glass fiber reinforced 20% G4 = Glass fiber reinforced 25% G5 = Glass fiber reinforced 30% (US 33%)				

*: see Product Data Sheets for available materials, colors, dimensions and features.

SF profile

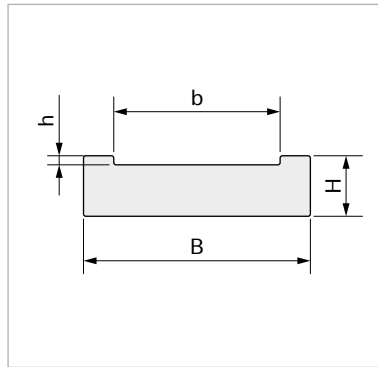
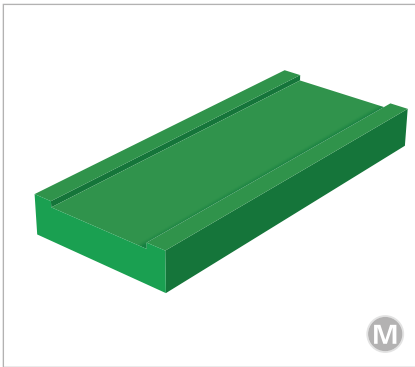

Application example

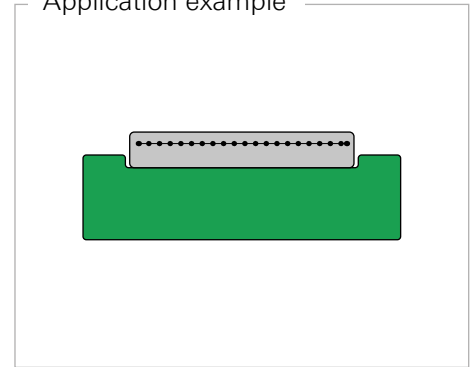

Habasit code	Belt types	B	H	b	h	Packaging unit	Total length
		mm	mm	mm	mm		m
SF-02-PE10G-003+RC	T5 16-AT5 16	25	10	17	1,8	bar	3
SF-03-PE10G-003+RC	T5 25-AT5 25	34	10	26	1,8	bar	3
SF-04-PE10G-003+RC	T5 32-AT5 32	41	10	33	1,8	bar	3
SF-05-PE10G-003+RC	T5 50-AT5 50	59	10	51	1,8	bar	3
SF-08-PE10G-003+RC	T10 16-AT10 16	25	15	17	3,8	bar	3
SF-09-PE10G-003+RC	T10 25-AT10 25	34	15	26	3,8	bar	3
SF-10-PE10G-003+RC	T10 32-AT10 32	41	15	33	3,8	bar	3
SF-11-PE10G-003+RC	T10 50-AT10 50	59	15	51	3,8	bar	3
SF-12-PE10G-003+RC	T10 75-AT10 75	84	15	76	3,8	bar	3
SF-13-PE10G-003+RC	T10 100-AT10 100	109	15	101	3,8	bar	3
SF-16-PE10G-003+RC	T20 25-AT20 25	34	20	26	7	bar	3
SF-17-PE10G-003+RC	T20 32-AT20 32	41	20	33	7	bar	3
SF-18-PE10G-003+RC	T20 50-AT20 50	59	20	51	7	bar	3
SF-19-PE10G-003+RC	T20 75-AT20 75	84	20	76	7	bar	3
SF-20-PE10G-003+RC	T20 100-AT20 100	109	20	101	7	bar	3

Material: PE UHMW Polyethylene, Green color

SF(X) profile

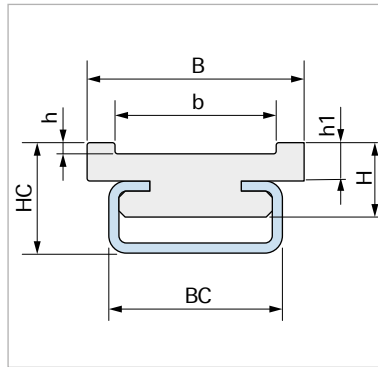
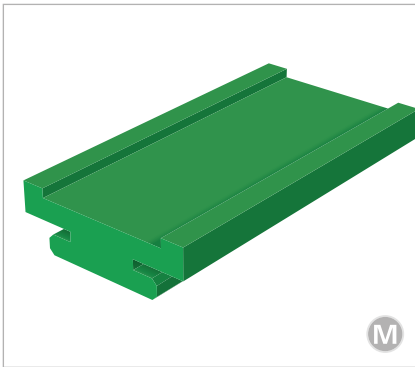

Application example

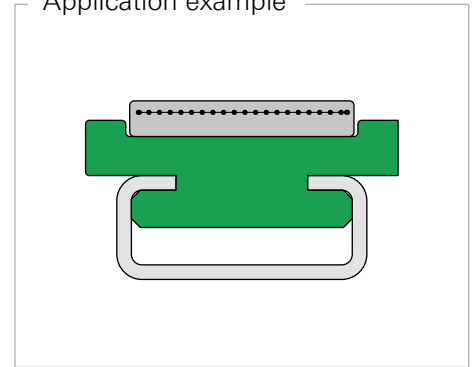

Habasit code	Belt types	B	H	BC	HC	h1	b	h	Suitable metal profile*	Packaging unit	Total length
		mm	mm	mm	mm	mm	mm	mm			m
SFE02-PE10G-003+RC	T5 16-AT5 16	25	15	28	19	7	17	1,8	CM-5	bar	3
SFE03-PE10G-003+RC	T5 25-AT5 25	34	15	28	19	7	26	1,8	CM-5	bar	3
SFJ04-PE10G-003+RC	T5 32-AT5 32	41	20	38	25	7	33	1,8	CM-9	bar	3
SFJ05-PE10G-003+RC	T5 50-AT5 50	59	20	38	25	7	51	1,8	CM-9	bar	3
SFE08-PE10G-003+RC	T10 16-AT10 16	25	17	28	21	9	17	3,8	CM-5	bar	3
SFE09-PE10G-003+RC	T10 25-AT10 25	34	17	28	21	9	26	3,8	CM-5	bar	3
SFJ10-PE10G-003+RC	T10 32-AT10 32	41	22	38	27	9	33	3,8	CM-9	bar	3
SFJ11-PE10G-003+RC	T10 50-AT10 50	59	22	38	27	9	51	3,8	CM-9	bar	3
SFJ12-PE10G-003+RC	T10 75-AT10 75	84	22	38	27	9	76	3,8	CM-9	bar	3
SFJ13-PE10G-003+RC	T10 100-AT10 100	109	22	38	27	9	101	3,8	CM-9	bar	3
SFE16-PE10G-003+RC	T20 25-AT20 25	34	20	28	24	12	26	7	CM-5	bar	3
SFJ17-PE10G-003+RC	T20 32-AT20 32	41	25	38	30	12	33	7	CM-9	bar	3
SFJ18-PE10G-003+RC	T20 50-AT20 50	59	25	38	30	12	51	7	CM-9	bar	3
SFJ19-PE10G-003+RC	T20 75-AT20 75	84	25	38	30	12	76	7	CM-9	bar	3
SFJ20-PE10G-003+RC	T20 100-AT20 100	109	25	38	30	12	101	7	CM-9	bar	3

Material: PE UHMW Polyethylene, Green color - * metal profile not included Suitable

SV profile

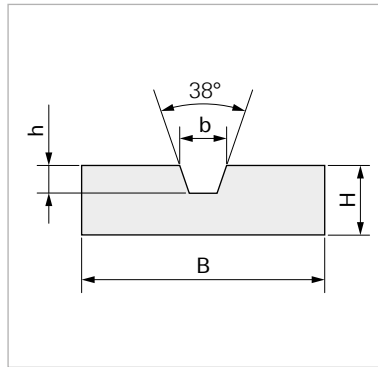
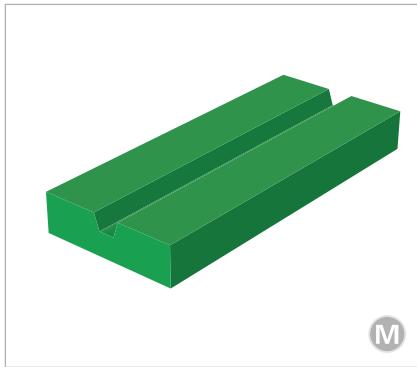

Application example

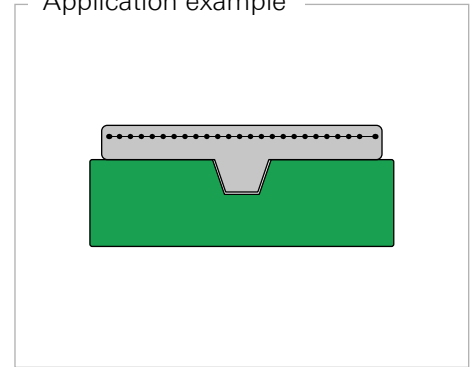

Habasit Code	Belt types	Track shape	B	H	b	h	Packaging unit	Total length
			mm	mm	mm	mm		m
SV-23-PE10G-003+RC	TG5 16-ATG5 16	G6	25	10	6	3,5	bar	3
SV-25-PE10G-003+RC	TG5 25-ATG5 25	G6	35	10	6	3,5	bar	3
SV-27-PE10G-003+RC	TG5 32-ATG5 32	G6	41	10	6	3,5	bar	3
SV-29-PE10G-003+RC	TG5 50-ATG5 50	G6	59	10	6	3,5	bar	3
SV-32-PE10G-003+RC	TG10 25-ATG10 25	G6	35	10	5,5	2,5	bar	3
SV-33-PE10G-003+RC	TG10 25-ATG10 25	G10	35	10	9,5	4,5	bar	3
SV-34-PE10G-003+RC	TG10 25-ATG10 25	G13	35	10	13	5	bar	3
SV-37-PE10G-003+RC	TG10 32-ATG10 32	G6	41	10	5,5	2,5	bar	3
SV-38-PE10G-003+RC	TG10 32-ATG10 32	G10	41	10	9,5	4,5	bar	3
SV-39-PE10G-003+RC	TG10 32-ATG10 32	G13	41	10	13	5	bar	3
SV-42-PE10G-003+RC	TG10 50-ATG10 50	G6	59	15	5,5	2,5	bar	3
SV-43-PE10G-003+RC	TG10 50-ATG10 50	G10	59	15	9,5	4,5	bar	3
SV-44-PE10G-003+RC	TG10 50-ATG10 50	G13	59	15	13	5	bar	3
SV-47-PE10G-003+RC	TG10 75-ATG10 75	G6	84	15	5,5	2,5	bar	3
SV-48-PE10G-003+RC	TG10 75-ATG10 75	G10	84	15	9,5	4,5	bar	3
SV-49-PE10G-003+RC	TG10 75-ATG10 75	G13	84	15	13	5	bar	3
SV-52-PE10G-003+RC	TG10 100-ATG10 100	G6	109	15	5,5	2,5	bar	3
SV-53-PE10G-003+RC	TG10 100-ATG10 100	G10	109	15	9,8	4,5	bar	3
SV-54-PE10G-003+RC	TG10 100-ATG10 100	G13	109	15	13	5	bar	3
SV-58-PE10G-003+RC	TG20 32-ATG20 32	G13	41	20	11,5	2,5	bar	3
SV-61-PE10G-003+RC	TG20 50-ATG20 50	G13	59	20	11,5	2,5	bar	3
SV-62-PE10G-003+RC	TG20 50-ATG20 50	G17	59	20	16	4	bar	3
SV-65-PE10G-003+RC	TG20 75-ATG20 75	G13	84	20	11,5	2,5	bar	3
SV-66-PE10G-003+RC	TG20 75-ATG20 75	G17	84	20	16	4	bar	3
SV-69-PE10G-003+RC	TG20 100-ATG20 100	G13	109	20	11,5	2,5	bar	3
SV-70-PE10G-003+RC	TG20 100-ATG20 100	G17	109	20	16	4	bar	3

Material: PE UHMW Polyethylene, Green color

SV(X) profile

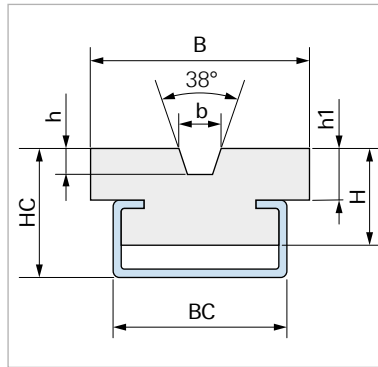
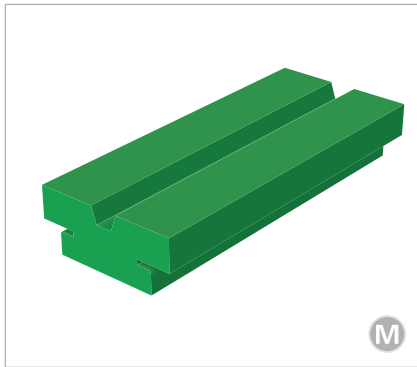

Application example

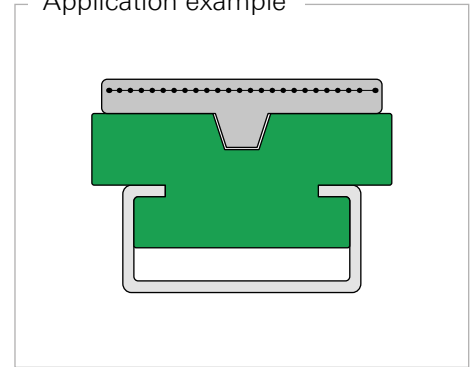

Habasit Code	Belt types	Track shape	B	H	BC	HC	h1	b	h	Suitable metal profile*	Packaging unit	Total length
			mm	mm	mm	mm	mm	mm	mm			m
SVE23-PE10G-003+RC	TG5 16-ATG5 16	G6	25	15	28	19	7	6	3,5	CM-5	bar	3
SVE25-PE10G-003+RC	TG5 25-ATG5 25	G6	35	15	28	19	7	6	3,5	CM-5	bar	3
SVJ27-PE10G-003+RC	TG5 32-ATG5 32	G6	41	20	38	25	7	6	3,5	CM-9	bar	3
SVJ29-PE10G-003+RC	TG5 50-ATG5 50	G6	59	20	38	25	7	6	3,5	CM-9	bar	3
SVE32-PE10G-003+RC	TG10 25-ATG10 25	G6	35	17	28	21	9	5,5	2,5	CM-5	bar	3
SVE33-PE10G-003+RC	TG10 25-ATG10 25	G10	35	17	28	21	9	9,5	4,5	CM-5	bar	3
SVE34-PE10G-003+RC	TG10 25-ATG10 25	G13	35	17	28	21	9	13	5	CM-5	bar	3
SVJ37-PE10G-003+RC	TG10 32-ATG10 32	G6	41	22	38	27	9	5,5	2,5	CM-9	bar	3
SVJ38-PE10G-003+RC	TG10 32-ATG10 32	G10	41	22	38	27	9	9,5	4,5	CM-9	bar	3
SVJ39-PE10G-003+RC	TG10 32-ATG10 32	G13	41	22	38	27	9	13	5	CM-9	bar	3
SVJ42-PE10G-003+RC	TG10 50-ATG10 50	G6	59	22	38	27	9	5,5	2,5	CM-9	bar	3
SVJ43-PE10G-003+RC	TG10 50-ATG10 50	G10	59	22	38	27	9	9,5	4,5	CM-9	bar	3
SVJ44-PE10G-003+RC	TG10 50-ATG10 50	G13	59	22	38	27	9	13	5	CM-9	bar	3
SVJ47-PE10G-003+RC	TG10 75-ATG10 75	G6	84	22	38	27	9	5,5	2,5	CM-9	bar	3
SVJ48-PE10G-003+RC	TG10 75-ATG10 75	G10	84	22	38	27	9	9,5	4,5	CM-9	bar	3
SVJ49-PE10G-003+RC	TG10 75-ATG10 75	G13	84	22	38	27	9	13	5	CM-9	bar	3
SVJ52-PE10G-003+RC	TG10 100-ATG10 100	G6	109	22	38	27	9	5,5	2,5	CM-9	bar	3
SVJ53-PE10G-003+RC	TG10 100-ATG10 100	G10	109	22	38	27	9	9,5	4,5	CM-9	bar	3
SVJ54-PE10G-003+RC	TG10 100-ATG10 100	G13	109	22	38	27	9	13	5	CM-9	bar	3
SVJ58-PE10G-003+RC	TG20 32-ATG20 32	G13	41	25	38	30	12	11,5	2,5	CM-9	bar	3
SVJ61-PE10G-003+RC	TG20 50-ATG20 50	G13	59	25	38	30	12	11,5	2,5	CM-9	bar	3
SVJ62-PE10G-003+RC	TG20 50-ATG20 50	G17	59	25	38	30	12	16	4	CM-9	bar	3
SVJ65-PE10G-003+RC	TG20 75-ATG20 75	G13	84	25	38	30	12	11,5	2,5	CM-9	bar	3
SVJ66-PE10G-003+RC	TG20 75-ATG20 75	G17	84	25	38	30	12	16	4	CM-9	bar	3
SVJ69-PE10G-003+RC	TG20 100-ATG20 100	G13	109	25	38	30	12	11,5	2,5	CM-9	bar	3
SVJ70-PE10G-003+RC	TG20 100-ATG20 100	G17	109	25	38	30	12	16	4	CM-9	bar	3

Material: PE UHMW Polyethylene, Green color - *metal profile not included

R1 profile

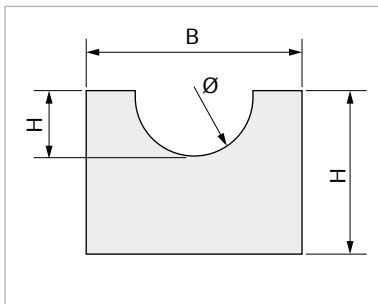
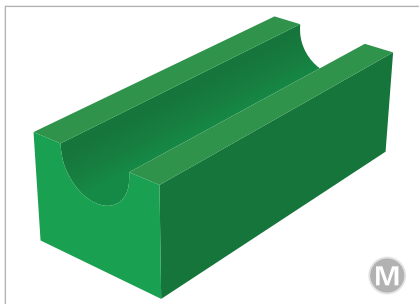

Application example

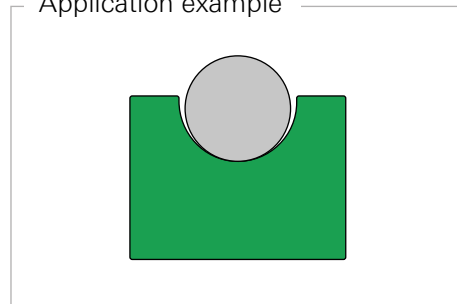

Habasit code	B	H	h	Ø	Packaging unit	Total length
	mm	mm	mm	mm		m
R1-04-PE10G-003+RC	15	10	2	4	bar	3
R1-05-PE10G-003+RC	15	10	2,5	5	bar	3
R1-06-PE10G-003+RC	20	10	3	6	bar	3
R1-08-PE10G-003+RC	20	10	4	8	bar	3
R1-10-PE10G-003+RC	25	12	5	10	bar	3
R1-12-PE10G-003+RC	25	12	6	12	bar	3
R1-15-PE10G-003+RC	25	15	7,5	15	bar	3

Material: PE UHMW Polyethylene, Green color

R1(X) profile

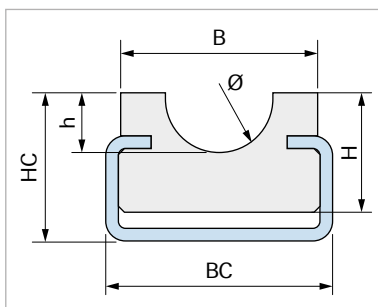
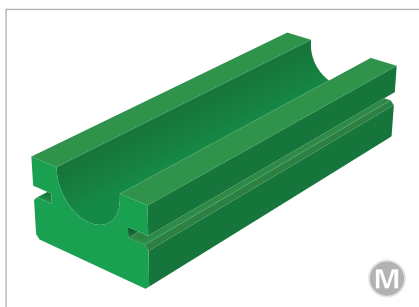

Application example

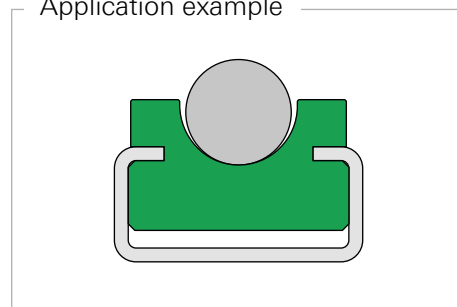

Habasit code	Code	B	H	BC	HC	h	Ø	Suitable metal profile*	Packaging unit	Total length
		mm	mm	mm	mm	mm	mm			m
R1C04-PE10G-003+RC	RC-02	20	10	20	14	2	4	CM-3	bar	3
R1C05-PE10G-003+RC	RC-04	20	10	20	14	2,5	5	CM-3	bar	3
R1C06-PE10G-003+RC	RC-06	20	10	20	14	3	6	CM-3	bar	3
R1C08-PE10G-003+RC	RC-08	20	10	20	14	4	8	CM-3	bar	3
R1E10-PE10G-003+RC	RC-10	25	15	28	18	5	10	CM-5	bar	3
R1E12-PE10G-003+RC	RC-12	25	15	28	18	6	12	CM-5	bar	3
R1E15-PE10G-003+RC	RC-14	25	15	28	20	7,5	15	CM-5	bar	3
R1E20-PE10G-003+RC	RC-16	28	20	28	24	10	20	CM-5	bar	3

Material: PE UHMW Polyethylene, Green color - *metal profile not included

V1 profile

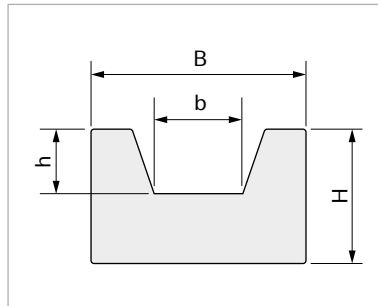
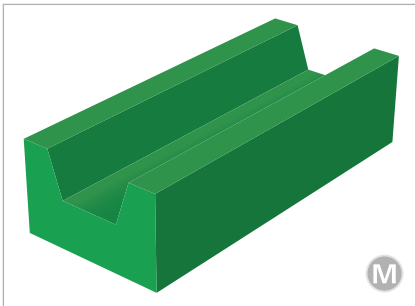

Application example

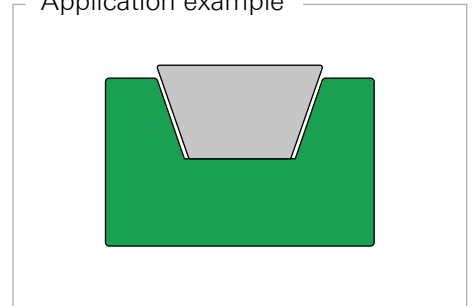

Habasit code	V-belt	B	H	b	h	Packaging unit	Total length
		mm	mm	mm	mm		m
V1-01-PE10G-003+RC	Z	20	10	6,5	3	bar	3
V1-04-PE10G-003+RC	A	20	12	8	5	bar	3
V1-05-PE10G-003+RC	SPB	25	12	9,5	5	bar	3
V1-08-PE10G-003+RC	B	30	15	10,5	8	bar	3
V1-09-PE10G-003+RC	C	35	20	13,5	11	bar	3
V1-11-PE10G-003+RC	D	40	25	19	13	bar	3

Material: PE UHMW Polyethylene, Green color

V1(X) profile

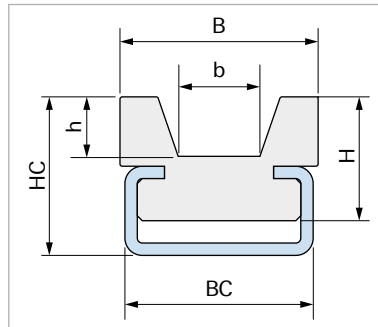
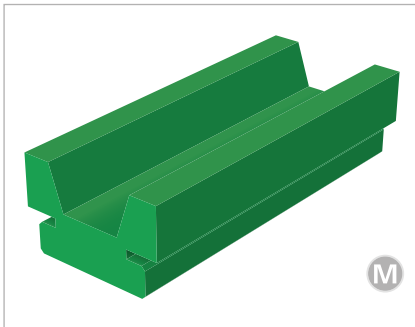

Application example

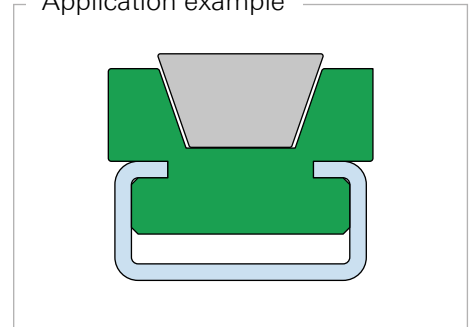

Habasit code	V-belt	B	H	BC	HC	b	h	Suitable metal profile*	Packaging unit	Total length
		mm	mm	mm	mm	mm	mm			m
V1C01-PE10G-003+RC	Z	20	15	20	17	6,5	3	CM-3	bar	3
V1C04-PE10G-003+RC	A	20	15	20	17	8	5	CM-3	bar	3
V1E05-PE10G-003+RC	SPB	25	20	28	24	9,5	5	CM-5	bar	3
V1E08-PE10G-002+RC	B	30	20	28	24	10,5	8	CM-5	bar	3
V1E08-PE10G-003+RC	B	30	20	28	24	10,5	8	CM-5	bar	3
V1J09-PE10G-003+RC	C	35	25	38	32	13,5	11	CM-9	bar	3
V1J11-PE10G-003+RC	D	40	25	38	35	19	13	CM-9	bar	3

Material: PE UHMW Polyethylene, Green color - *metal profile not included

T1 profile

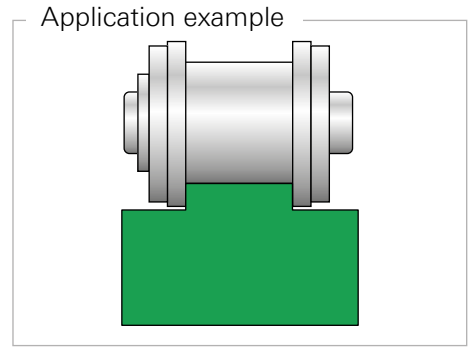
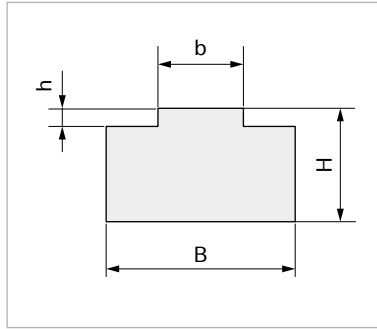
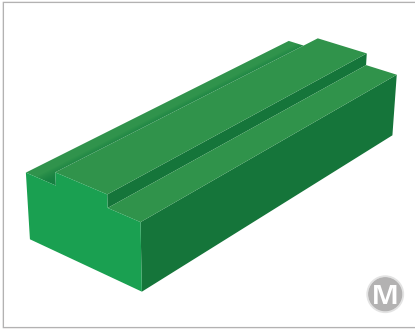

Habasit Code	Chain	ISO606	B	H	b	h	Packaging unit	Total length
		(DIN8187)	mm	mm	mm	mm		m
T1-01-PE10G-003+RC	3/8"x7/32"	06 B-1	15	10	5,4	1,5	bar	3
T1-05-PE10G-003+RC	1/2"x5/16"	08 B-1	20	10	7,4	2,2	bar	3
T1-06-PE10G-003+RC	1/2"x5/16"	08 B-1	20	15	7,4	2,2	bar	3
T1-07-PE10G-003+RC	1/2"x5/16"	08 B-1	20	20	7,4	2,2	bar	3
T1-09-PE10G-003+RC	5/8"x3/8"	10 B-1	20	10	9,2	2,6	bar	3
T1-10-PE10G-003+RC	5/8"x3/8"	10 B-1	20	15	9,2	2,6	bar	3
T1-11-PE10G-003+RC	5/8"x3/8"	10 B-1	20	20	9,2	2,6	bar	3
T1-13-PE10G-003+RC	3/4"x7/16"	12 B-1	25	10	11,3	2,4	bar	3
T1-14-PE10G-003+RC	3/4"x7/16"	12 B-1	25	15	11,3	2,4	bar	3
T1-15-PE10G-003+RC	3/4"x7/16"	12 B-1	25	20	11,3	2,4	bar	3
T1-18-PE10G-003+RC	1"x17mm	16 B-1	40	15	16,5	3,5	bar	3
T1-19-PE10G-003+RC	1"x17mm	16 B-1	40	20	16,5	3,5	bar	3
T1-21-PE10G-003+RC	1 1/4"x3/4"	20 B-1	45	15	19	4,3	bar	3
T1-22-PE10G-003+RC	1 1/4"x3/4"	20 B-1	45	20	19	4,3	bar	3
T1-24-PE10G-003+RC	1 1/2"x1"	24 B-1	60	15	24,6	5,6	bar	3
T1-25-PE10G-003+RC	1 1/2"x1"	24 B-1	60	20	24,6	5,6	bar	3
T1-27-PE10G-003+RC	1 3/4"x31mm	28 B-1	75	20	30	6,9	bar	3
T1-30-PE10G-003+RC	2"x31mm	32 B-1	80	20	30	7,8	bar	3

Habasit Code	Chain	ASA	B	H	b	h	Packaging unit	Total length
		(DIN 8188)	mm	mm	mm	mm		m
T1-51-PE10G-003+RC	3/8"x3/16"	06 A-1	15	10	4	2,2	bar	3
T1-54-PE10G-003+RC	1/2"x5/16"	08 A-1	20	10	7,1	2,3	bar	3
T1-55-PE10G-003+RC	1/2"x5/16"	08 A-1	20	15	7,1	2,3	bar	3
T1-56-PE10G-003+RC	1/2"x5/16"	08 A-1	20	20	7,1	2,3	bar	3
T1-58-PE10G-003+RC	5/8"x3/8"	10 A-1	20	10	8,6	2,7	bar	3
T1-59-PE10G-003+RC	5/8"x3/8"	10 A-1	20	15	8,6	2,7	bar	3
T1-60-PE10G-003+RC	5/8"x3/8"	10 A-1	20	20	8,6	2,7	bar	3
T1-62-PE10G-003+RC	3/4"x1/2"	12 A-1	25	10	11,9	3,4	bar	3
T1-63-PE10G-003+RC	3/4"x1/2"	12 A-1	25	15	11,9	3,4	bar	3
T1-64-PE10G-003+RC	3/4"x1/2"	12 A-1	25	20	11,9	3,4	bar	3
T1-67-PE10G-003+RC	1"x5/8"	16 A-1	40	15	15,1	4,5	bar	3
T1-68-PE10G-003+RC	1"x5/8"	16 A-1	40	20	15,1	4,5	bar	3

Material: PE UHMW Polyethylene, Green color

T1(X) profile

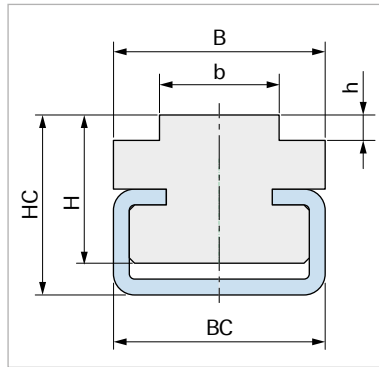
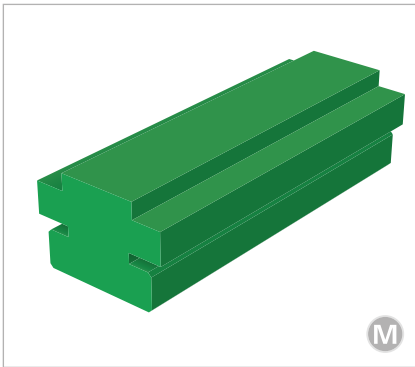

Application example

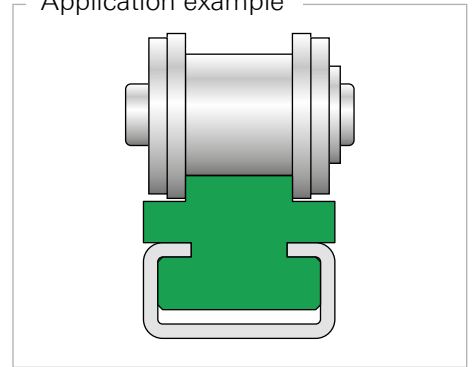

Habasit code	Chain	ISO 606	B	H	BC	HC	b	h	Suitable metal profile*	Packaging unit	Total length
		(DIN 8187)	mm	mm	mm	mm	mm	mm			m
T1C02-PE10G-003+RC	3/8"x7/32"	06 B-1	20	15	20	17	5,4	1,5	CM-3	bar	3
T1C06-PE10G-003+RC	1/2"x5/16"	08 B-1	20	15	20	17	7,4	2,2	CM-3	bar	3
T1C10-PE10G-003+RC	5/8"x3/8"	10 B-1	20	15	20	17	9,2	2,6	CM-3	bar	3
T1C14-PE10G-003+RC	3/4"x7/16"	12 B-1	20	15	20	17	11,3	2,4	CM-3	bar	3
T1E18-PE10G-003+RC	1"x17mm	16 B-1	28	15	28	18	16,5	3,5	CM-5	bar	3
T1J13-PE10G-003+RC	1 1/4"x3/4"	20 B-1	38	20	38	27	19	4,3	CM-9	bar	3

Material: PE UHMW Polyethylene, Green color - *metal profile not included

T2 profile

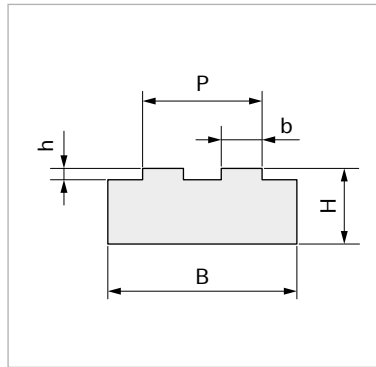
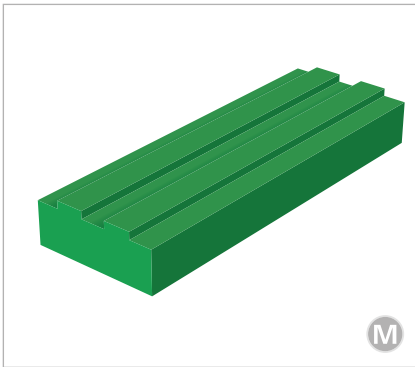

Application example

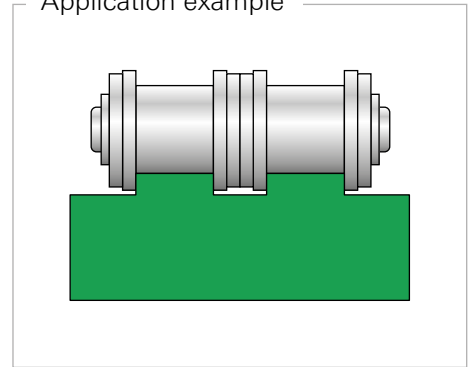

Habasit Code	Chain	ISO 606	B	H	b	h	P	Packaging unit	Total length
		(DIN8187)							mm
T2-01-PE10G-003+RC	3/8"x7/32"	06 B-2	25	10	5,4	1,5	15,8	bar	3
T2-05-PE10G-003+RC	1/2"x5/16"	08 B-2	35	10	7,4	2,2	21,4	bar	3
T2-06-PE10G-003+RC	1/2"x5/16"	08 B-2	35	15	7,4	2,2	21,4	bar	3
T2-07-PE10G-003+RC	1/2"x5/16"	08 B-2	35	20	7,4	2,2	21,4	bar	3
T2-09-PE10G-003+RC	5/8"x3/8"	10 B-2	40	10	9,2	2,6	25,8	bar	3
T2-10-PE10G-003+RC	5/8"x3/8"	10 B-2	40	15	9,2	2,6	25,8	bar	3
T2-11-PE10G-003+RC	5/8"x3/8"	10 B-2	40	20	9,2	2,6	25,8	bar	3
T2-13-PE10G-003+RC	3/4"x7/16"	12 B-2	45	10	11,3	2,4	30,8	bar	3
T2-14-PE10G-003+RC	3/4"x7/16"	12 B-2	45	15	11,3	2,4	30,8	bar	3
T2-15-PE10G-003+RC	3/4"x7/16"	12 B-2	45	20	11,3	2,4	30,8	bar	3
T2-18-PE10G-003+RC	1"x17mm	16 B-2	65	15	16,5	3,5	48,4	bar	3
T2-19-PE10G-003+RC	1"x17mm	16 B-2	65	20	16,5	3,5	48,4	bar	3
T2-21-PE10G-003+RC	1 1/4"x3/4"	20 B-2	70	15	19	4,3	54,5	bar	3
T2-22-PE10G-003+RC	1 1/4"x3/4"	20 B-2	70	20	19	4,3	54,5	bar	3
T2-25-PE10G-003+RC	1 1/2"x1"	24 B-2	88	20	24,6	5,6	73	bar	3
T2-28-PE10G-003+RC	1 3/4"x31mm	28 B-2	105	25	30	6,9	89,6	bar	3
T2-32-PE10G-003+RC	2"x31mm	32 B-2	105	30	30	7,8	88,7	bar	3

Habasit Code	Chain	ASA	B	H	b	h	P	Packaging unit	Total length
		(DIN 8188)							mm
T2-51-PE10G-003+RC	3/8"x3/16"	06 A-2	25	10	4	2,2	14,1	bar	3
T2-54-PE10G-003+RC	1/2"x5/16"	08 A-2	35	10	7,1	2,3	21,5	bar	3
T2-55-PE10G-003+RC	1/2"x5/16"	08 A-2	35	15	7,1	2,3	21,5	bar	3
T2-56-PE10G-003+RC	1/2"x5/16"	08 A-2	35	20	7,1	2,3	21,5	bar	3
T2-58-PE10G-003+RC	5/8"x3/8"	10 A-2	40	10	8,6	2,7	26,7	bar	3
T2-59-PE10G-003+RC	5/8"x3/8"	10 A-2	40	15	8,6	2,7	26,7	bar	3
T2-60-PE10G-003+RC	5/8"x3/8"	10 A-2	40	20	8,6	2,7	26,7	bar	3
T2-62-PE10G-003+RC	3/4"x1/2"	12 A-2	45	10	11,9	3,4	34,7	bar	3
T2-63-PE10G-003+RC	3/4"x1/2"	12 A-2	45	15	11,9	3,4	34,7	bar	3
T2-64-PE10G-003+RC	3/4"x1/2"	12 A-2	45	20	11,9	3,4	34,7	bar	3
T2-67-PE10G-003+RC	1"x5/8"	16 A-2	55	15	15,1	4,5	44,4	bar	3
T2-68-PE10G-003+RC	1"x5/8"	16 A-2	55	20	15,1	4,5	44,4	bar	3

Material: PE UHMW Polyethylene, Green color

T2(X) profile

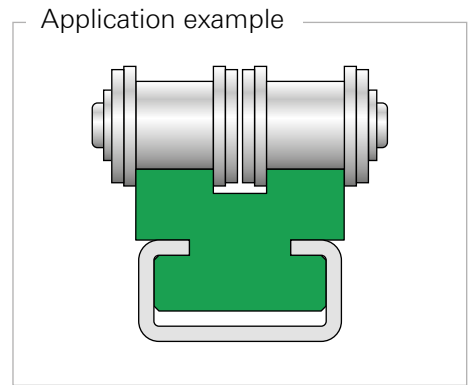
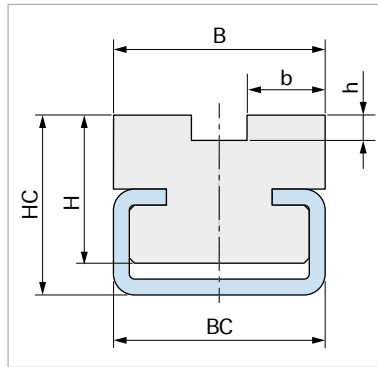
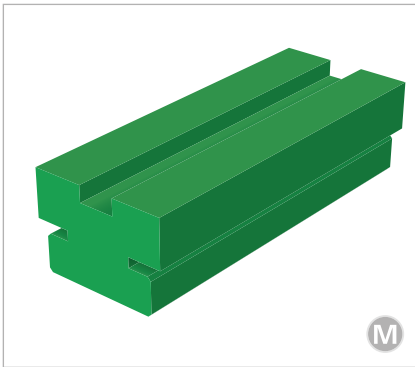

Habasit code	Chain	ISO 606	B	H	BC	HC	b	h	Suitable metal profile*	Packaging unit	Total length
		(DIN 8187)	mm	mm	mm	mm	mm	mm			m
T2C02-PE10G-003+RC	3/8"x7/32"	06 B-2	15,7	15	20	17	5,4	1,5	CM-3	bar	3
T2C06-PE10G-003+RC	1/2"x5/16"	08 B-2	21,4	15	20	17	7,4	2,2	CM-3	bar	3
T2E10-PE10G-003+RC	5/8"x3/8"	10 B-2	25,9	15	28	19	9,2	2,6	CM-5	bar	3
T2E14-PE10G-003+RC	3/4"x7/16"	12 B-2	30,7	15	28	19	11,3	2,4	CM-5	bar	3
T2J19-PE10G-003+RC	1"x17mm	16 B-2	48,3	20	38	27	16,5	3,5	CM-9	bar	3

Material: PE UHMW Polyethylene, Green color - *metal profile not included

T3 profile

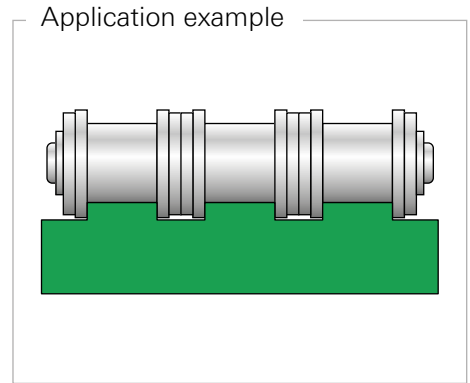
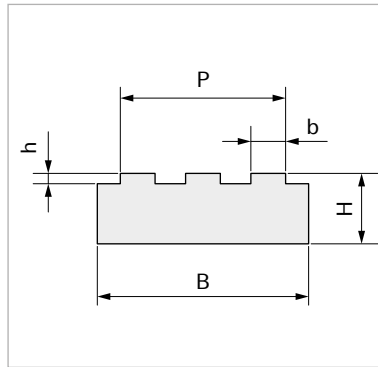
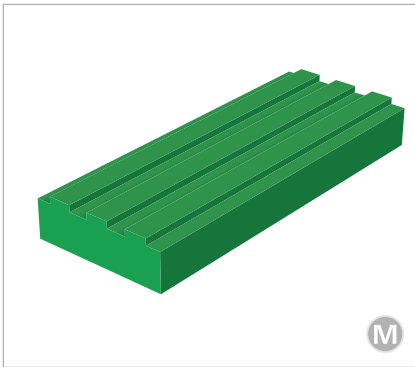

Habasit code	Chain	ISO 606	B	H	b	h	P	Packaging unit	Total length
		(DIN 8187)	mm	mm	mm	mm	mm		m
T3-01-PE10G-003+RC	3/8"x7/32"	06 B-3	35	10	5,4	1,5	25,9	bar	3
T3-05-PE10G-003+RC	1/2"x5/16"	08 B-3	45	10	7,4	2,2	35,2	bar	3
T3-26-PE10G-003+RC	1/2"x5/16"	08 B-3	45	15	7,4	2,2	35,2	bar	3
T3-07-PE10G-003+RC	1/2"x5/16"	08 B-3	45	20	7,4	2,2	35,2	bar	3
T3-09-PE10G-003+RC	5/8"x3/8"	10 B-3	55	10	9,2	2,6	42,4	bar	3
T3C10-PE10G-003+RC	5/8"x3/8"	10 B-3	55	15	9,2	2,6	42,4	bar	3
T3C11-PE10G-003+RC	5/8"x3/8"	10 B-3	55	20	9,2	2,6	42,4	bar	3
T3-14-PE10G-003+RC	3/4"x7/16"	12 B-3	60	15	11,3	2,4	50,2	bar	3
T3-15-PE10G-003+RC	3/4"x7/16"	12 B-3	60	20	11,3	2,4	50,2	bar	3
T3-19-PE10G-003+RC	1"x17mm	16 B-3	95	20	16,5	3,5	80,3	bar	3

Material: PE UHMW Polyethylene, Green color

E1 profile

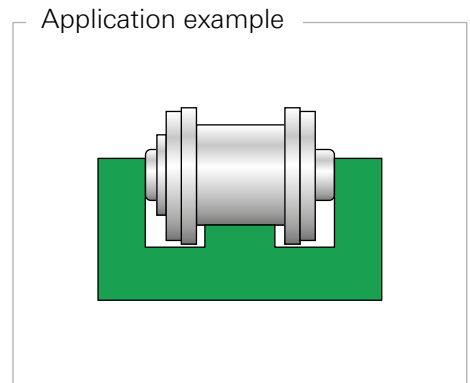
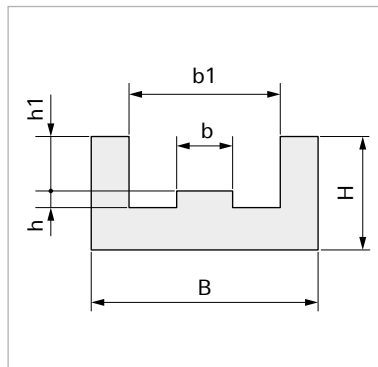
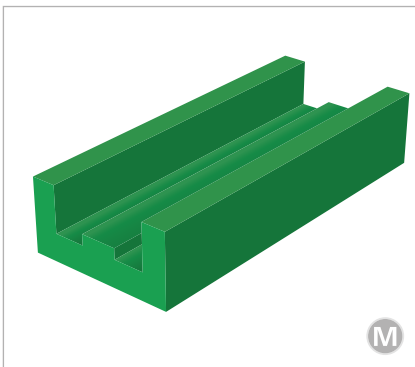

Habasit code	Chain	ISO 606	B	H	b1	h1	b	h	Packaging unit	Total length
		(DIN 8187)	mm	mm	mm	mm	mm	mm		m
E1-01-PE10G-003+RC	3/8"x7/32"	06 B-1	25	10	15	4,4	5,4	1,5	bar	3
E1-06-PE10G-003+RC	1/2"x5/16"	08 B-1	30	15	20	7,2	7,4	2,2	bar	3
E1-09-PE10G-003+RC	5/8"x3/8"	10 B-1	33	20	23	9,5	9,2	2,6	bar	3
E1-13-PE10G-003+RC	3/4"x7/16"	12 B-1	38	20	28	11,1	11,3	2,4	bar	3
E1-17-PE10G-003+RC	1"x17mm	16 B-1	51	25	41	16,5	16,5	3,5	bar	3

Material: PE UHMW Polyethylene, Green color

E1(X) profile

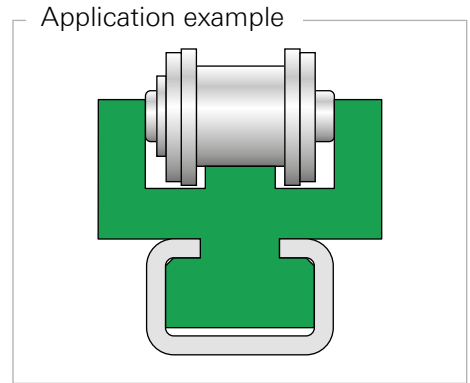
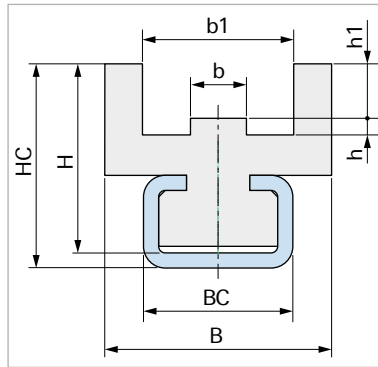
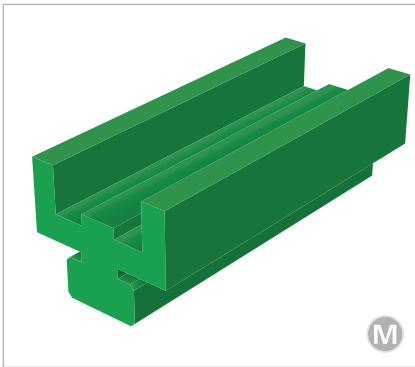

Habasit code	Chain	ISO606	B	H	BC	HC	b1	h1	b	h	Suitable metal profile*	Packaging unit	Total length
		(DIN8187)	mm	mm	mm	mm	mm	mm	mm	mm			m
E1C01-PE10G-003+RC	3/8"x7/32"	06 B-1	25	18	20	20	15	4,4	5,4	1,5	CM-3	bar	3
E1C08-PE10G-003+RC	1/2"x5/16"	08 B-1	30	25	20	27	20	7,2	7,4	2,2	CM-3	bar	3
E1E09-PE10G-003+RC	5/8"x3/8"	10 B-1	33	30	28	32	23	9,5	9,2	2,6	CM-5	bar	3
E1J13-PE10G-003+RC	3/4"x7/16"	12 B-1	38	35	38	38,5	28	11,1	11,3	2,4	CM-9	bar	3
E1J17-PE10G-003+RC	1"x17mm	16 B-1	51	40	38	43,5	41	16,5	16,5	3,5	CM-9	bar	3

Material: PE UHMW Polyethylene, Green color - *metal profile not included

E2 profile

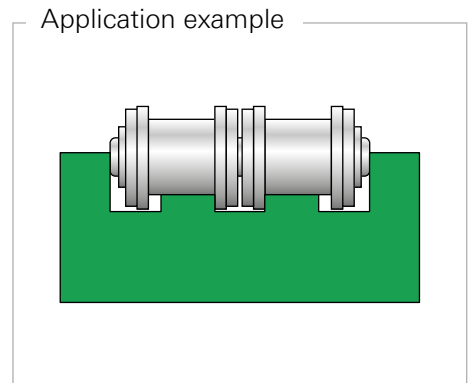
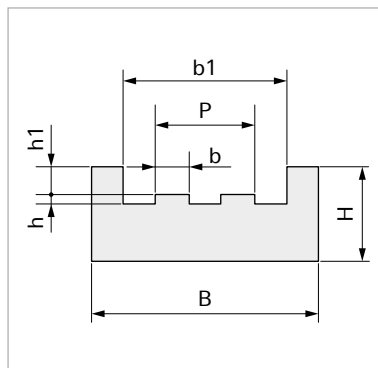
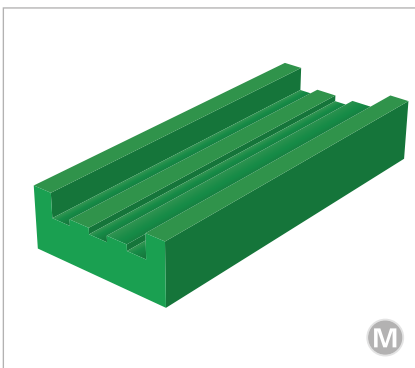

Habasit code	Chain	ISO 606	B	H	b1	h1	b	h	P	Packaging unit	Total length
		(DIN 8187)	mm	mm	mm	mm	mm	mm	mm		m
E2-01-PE10G-003+RC	3/8"x7/32"	06 B-2	36	15	26	4,4	5,4	1,5	15,8	bar	3
E2-07-PE10G-003+RC	1/2"x5/16"	08 B-2	45	20	35	7,2	7,4	2,2	21,4	bar	3
E2-09-PE10G-003+RC	5/8"x3/8"	10 B-2	50	25	40	9,5	9,2	2,6	25,8	bar	3
E2-13-PE10G-003+RC	3/4"x7/16"	12 B-2	56	25	46	11,1	11,3	2,4	30,8	bar	3
E2-17-PE10G-003+RC	1"x17mm	16 B-2	85	30	75	16,5	16,5	3,5	48,8	bar	3

Material: PE UHMW Polyethylene, Green color

E2(X) profile

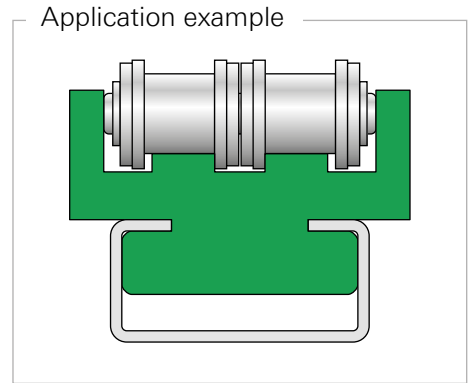
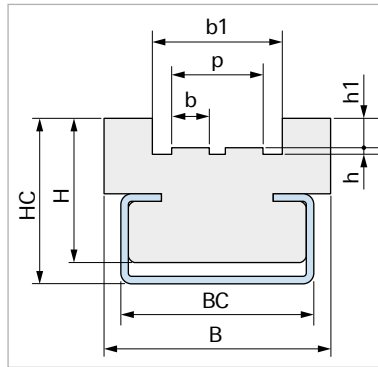
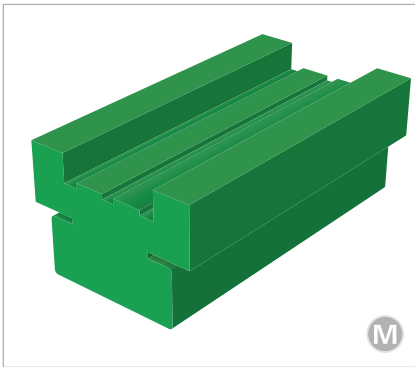

Habasit code	Chain	ISO606	B	H	BC	HC	b1	h1	b	h	P	Suitable metal profile*	Packaging unit	Total length
		(DIN8187)												
E2E01-PE10G-003+RC	3/8"x7/32"	06 B-1	36	18	28	22	26	4,4	5,4	1,5	15,8	CM-5	bar	3
E2J08-PE10G-003+RC	1/2"x5/16"	08 B-1	45	25	38	33	35	7,2	7,4	2,2	21,4	CM-9	bar	3
E2J09-PE10G-003+RC	5/8"x3/8"	10 B-1	50	30	38	37	40	9,5	9,2	2,6	25,8	CM-9	bar	3
E2J13-PE10G-003+RC	3/4"x7/16"	12 B-1	56	35	38	38,5	46	11,1	11,3	2,4	30,8	CM-9	bar	3
E2J17-PE10G-003+RC	1"x17mm	16 B-1	85	40	38	43,5	75	16,5	16,5	3,5	48,4	CM-9	bar	3

Material: PE UHMW Polyethylene, Green color - *metal profile not included

ET(X) profile

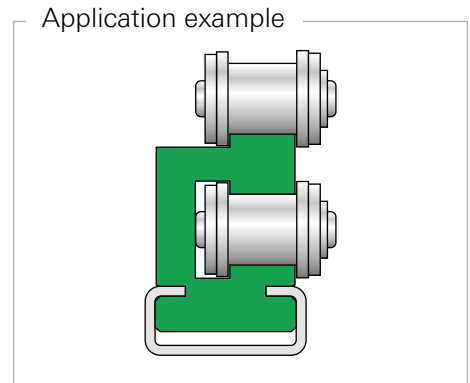
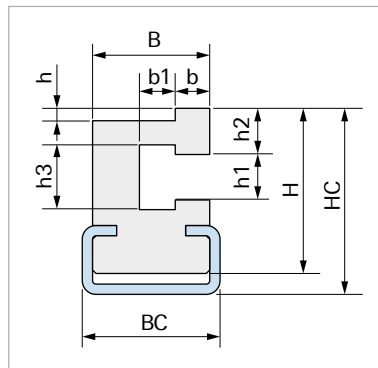
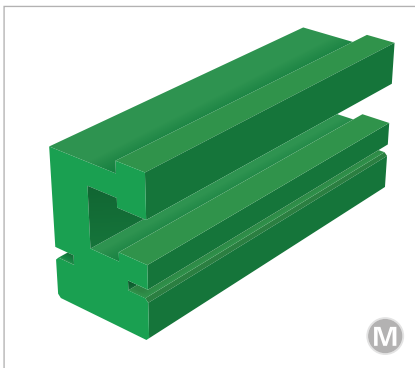

Habasit code	Chain	ISO606	B	H	BC	HC	b1	h1	h2	h3	b	h	Suitable metal profile*	Packaging unit	Total length
		(DIN8187)													
ETC01-PE10G-003+RC	3/8"x7/32"	06 B-1	20	26,4	20	28,7	4,4	6,6	5,5	9,3	5,4	1,4	CM-3	bar	3
ETC05-PE10G-003+RC	1/2"x5/16"	08 B-1	20	28	20	30,5	5,9	8,7	7,3	12,8	7,4	2	CM-3	bar	3
ETC09-PE10G-003+RC	5/8"x3/8"	10 B-1	20	34,1	20	36	5,3	10,7	9,5	15,4	9,2	2,5	CM-3	bar	3
ETE13-PE10G-003+RC	3/4"x7/16"	12 B-1	24	38,5	28	41,5	6	12,3	10,5	16,9	11,3	2,3	CM-5	bar	3
ETJ17-PE10G-003+RC	1"x17mm	16 B-1	33,5	52,4	38	61,5	10,7	16,1	18,3	24,4	16,5	4,1	CM-9	bar	3

Material: PE UHMW Polyethylene, Green color - *metal profile not included

U1 profile

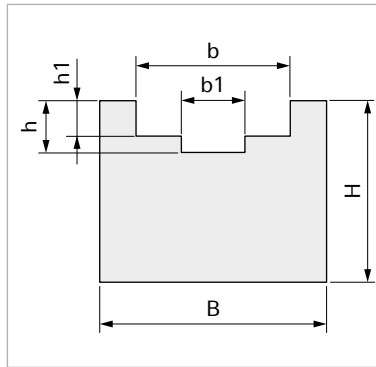
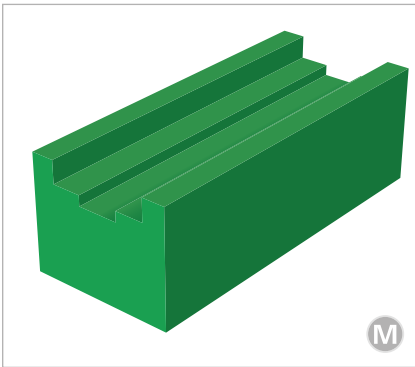

Application example

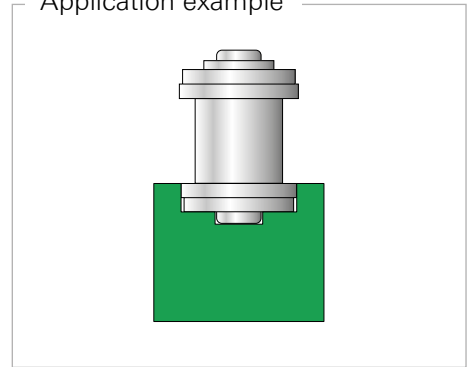

Habasit code	Chain	ISO606	B	H	b	b1	h	h1	Packaging unit	Total length
		(DIN8187)	mm	mm	mm	mm	mm	mm		m
U1-01-PE10G-003+RC	3/8"x7/32"	06 B-1	20	15	9,2	4	4,2	2,8	bar	3
U1-06-PE10G-003+RC	1/2"x5/16"	08 B-1	25	15	12,7	5	4,8	3,5	bar	3
U1-09-PE10G-003+RC	5/8"x3/8"	10 B-1	25	15	15,2	6	5,1	3,6	bar	3
U1-13-PE10G-003+RC	3/4"x7/16"	12 B-1	25	20	16,7	7	5,7	3,9	bar	3
U1-17-PE10G-003+RC	1"x17mm	16 B-1	35	25	24,2	9	10	8,4	bar	3

Material: PE UHMW Polyethylene, Green color

U1(X) profile

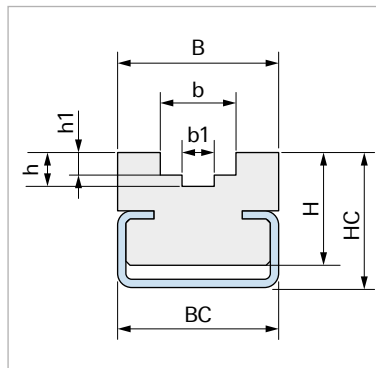
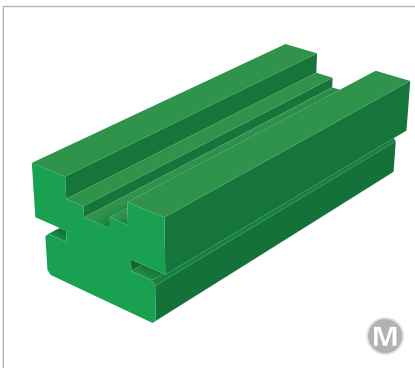

Application example

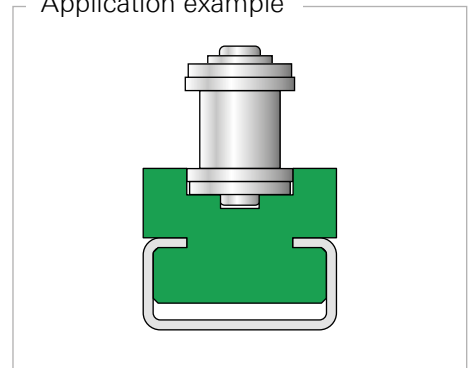

Habasit code	Chain	ISO606	B	H	BC	HC	b1	h1	b	h	Suitable metal profile*	Packaging unit	Total length
		(DIN8187)	mm	mm	mm	mm	mm	mm	mm	mm	mm		m
U1C06-PE10G-003+RC	1/2"x5/16"	08 B-1	20	15	20	18	5	3,5	12,7	4,8	CM-3	bar	3
U1C09-PE10G-003+RC	5/8"x3/8"	10 B-1	23	15	20	18	6	3,6	15,2	5,1	CM-3	bar	3
U1C13-PE10G-003+RC	3/4"x7/16"	12 B-1	23	20	20	23	7	3,9	16,7	5,7	CM-3	bar	3
U1E17-PE10G-003+RC	1"x17mm	16 B-1	32	25	28	28	8	8,4	24,4	10	CM-3	bar	3

Material: PE UHMW Polyethylene, Green color - *metal profile not included

B1 profile

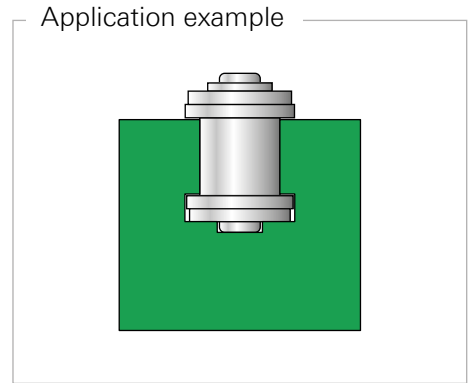
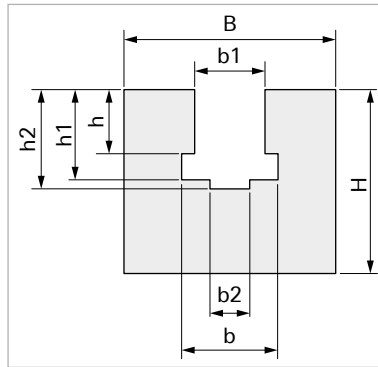
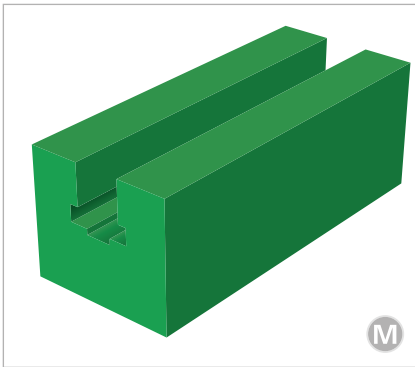

Habasit code	Chain	ISO606	B	H	b1	b2	h1	h2	b	h	Packaging unit	Total length
		(DIN8187)	mm	mm	mm	mm	mm	mm	mm	mm		m
B1-01-PE10G-003+RC	3/8"x7/32"	06 B-1	20	25	6,6	4	8,7	10	9,3	5,6	bar	3
B1-05-PE10G-003+RC	1/2"x5/16"	08 B-1	24	30	8,7	5	11,5	13,5	12,8	7,6	bar	3
B1-09-PE10G-003+RC	5/8"x3/8"	10 B-1	30	35	10,4	6	13,5	14,8	15,4	9,5	bar	3
B1-13-PE10G-003+RC	3/4"x7/16"	12 B-1	40	35	12,3	7	15,9	17,5	16,9	11,5	bar	3
B1-17-PE10G-003+RC	1"x17mm	16 B-1	40	45	16,1	9	25,7	26,8	24,4	16,1	bar	3
B1-20-PE10G-003+RC	1 1/4"x3/4"	20 B-1	50	50	19,3	11	29,3	31,2	27,5	19,4	bar	3
B1-24-PE10G-003+RC	1 1/2"x1"	24 B-1	60	60	25,7	16	38,2	40,1	36,5	25,2	bar	3
B1-26-PE10G-003+RC	1 3/4"x31mm	28 B-1	60	70	28,3	17	46,9	48,9	41,5	30,8	bar	3
B1-30-PE10G-003+RC	2"x31mm	32 B-1	70	75	29,6	19	47,3	53	44,5	30,8	bar	3

Material: PE UHMW Polyethylene, Green color

B1(X) profile

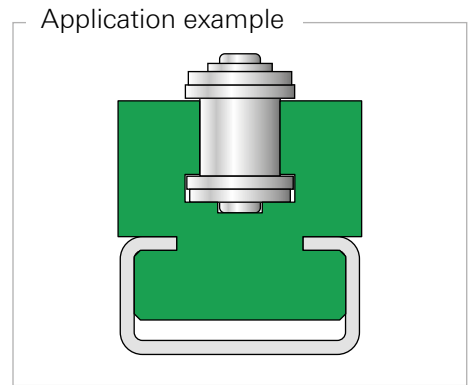
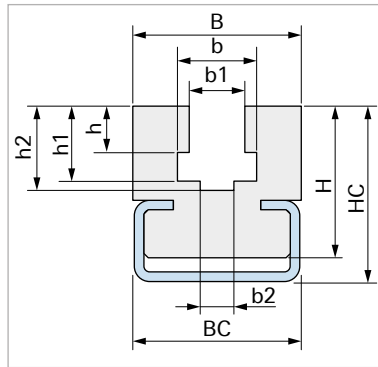
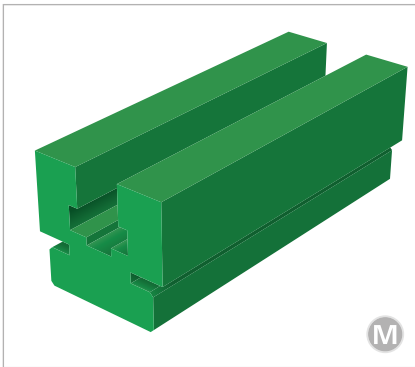

Habasit code	Chain	ISO606	B	H	BC	HC	b1	b2	h1	h2	b	h	Suitable metal profile*	Packaging unit	Total length
		(DIN8187)	mm	mm	mm	mm	mm	mm	mm	mm	mm	mm			m
B1C01-PE10G-003+RC	3/8"x7/32"	06 B-1	20	17,5	20	21	6,6	4	8,7	10	9,3	5,6	CM-3	bar	3
B1E05-PE10G-003+RC	1/2"x5/16"	08 B-1	24	27,5	28	32	8,7	5	11,5	13,5	12,8	7,6	CM-5	bar	3
B1E09-PE10G-003+RC	5/8"x3/8"	10 B-1	24	27,5	28	32	10,4	6	13,5	14,8	15,4	9,5	CM-5	bar	3
B1J13-PE10G-003+RC	3/4"x7/16"	12 B-1	33	34	38	42	12,3	7	15,9	17,5	16,9	11,5	CM-9	bar	3
B1K17-PE10G-003+RC	1"x17mm	16 B-1	38	40	38	50	16,1	9	25,7	26,8	24,4	16,1	CM-9	bar	3

Material: PE UHMW Polyethylene, Green color - *metal profile not included

K1(X) profile

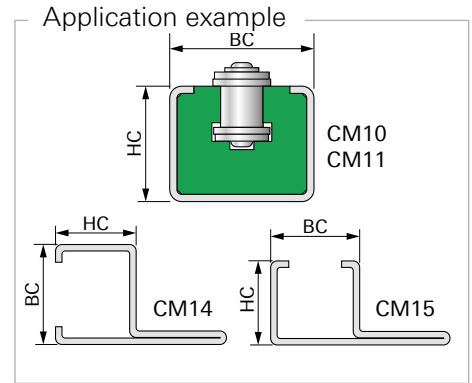
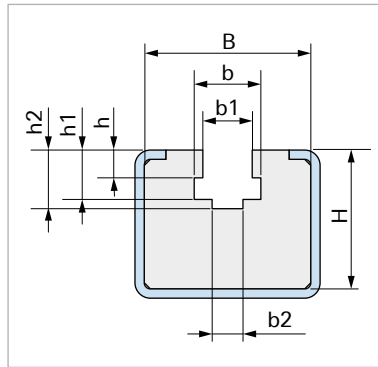
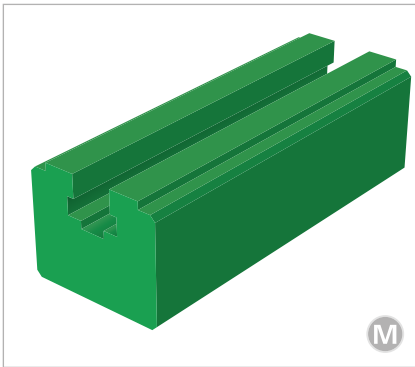

Habasit code	Chain	ISO606	B	H	BC	HC	b1	b2	h1	h2	b	h	Suitable metal profile*	Packaging unit	Total length
		(DIN8187)													
K1P01-PE10G-003+RC	3/8"x7/32"	06 B-1	27	23	31	25	6,6	4	8,7	10	9,3	5,6	CM-14/ CM-15	bar	3
K1P05-PE10G-003+RC	1/2"x5/16"	08 B-1	27	23	31	25	8,7	5	11,5	13,5	12,8	7,6	CM-14/ CM-15	bar	3
K1P09-PE10G-003+RC	5/8"x3/8"	10 B-1	27	23	31	25	10,4	6	13,5	14,8	15,4	9,5	CM-14/ CM-15	bar	3
K1P13-PE10G-003+RC	3/4"x7/16"	12 B-1	27	23	31	25	12,3	7	15,9	17,5	16,9	11,5	CM-14/ CM-15	bar	3
K1K01-PE10G-003+RC	3/8"x7/32"	6 B-1	27	22,5	30	24	6,6	4	8,7	10	9,3	5,6	CM-10	bar	3
K1K05-PE10G-003+RC	1/2"x5/16"	8 B-1	27	22,5	30	24	8,7	5	11,5	13,5	12,8	7,6	CM-10	bar	3
K1K09-PE10G-003+RC	5/8"x3/8"	10 B-1	27	22,5	30	24	10,4	6	13,5	14,8	15,4	9,5	CM-10	bar	3
K1K13-PE10G-003+RC	3/4"x7/16"	12 B-1	27	22,5	30	24	12,3	7	15,9	17,5	16,9	11,5	CM-10	bar	3
K1M17-PE10G-003+RC	1"x17mm	16 B-1	42	38,5	45	40	16,1	9	25,7	26,8	24,4	16,1	CM-11	bar	3
K1M20-PE10G-003+RC	1 1/4"x3/4"	20 B-1	42	38,5	45	40	19,3	11	29,3	31,2	27,5	19,5	CM-11	bar	3

Material: PE UHMW Polyethylene, Green color - *metal profile not included

CM3-CM5-CM9 Metallic profiles

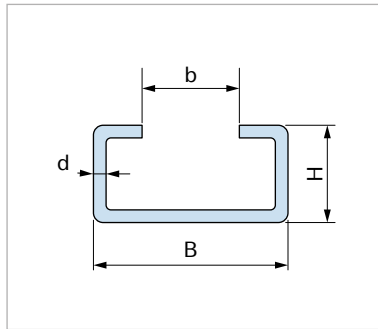
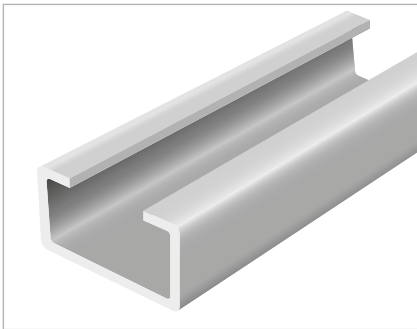

Application example

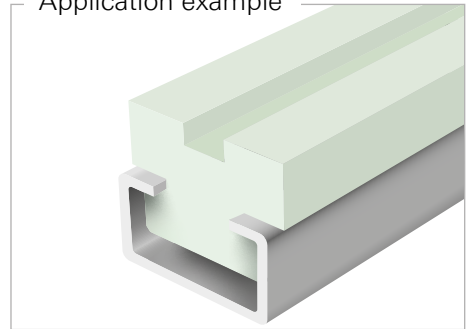

Habasit code	B	H	b	d	Material	Packaging unit	Total Length	Weight
	mm	mm	mm	mm			m	kg/m
CM-03-GALVX-003	20	10	10	1,5	Galvanized steel	bar	3	0,43
CM-03-GALVX-006	20	10	10	1,5	Galvanized steel	bar	6	0,43
CM-03-A304X-003	20	10	10	1,5	AISI 304 Stainless steel	bar	3	0,43
CM-03-A304X-006	20	10	10	1,5	AISI 304 Stainless steel	bar	6	0,43
CM-05-GALVX-003	28	12	14	1,5	Galvanized steel	bar	3	0,85
CM-05-GALVX-006	28	12	14	1,5	Galvanized steel	bar	6	0,85
CM-05-A304X-003	28	12	14	1,5	AISI 304 Stainless steel	bar	3	0,85
CM-05-A304X-006	28	12	14	1,5	AISI 304 Stainless steel	bar	6	0,85
CM-09-GALVX-003	38	18	22	1,5	Galvanized steel	bar	3	0,98
CM-09-GALVX-006	38	18	22	1,5	Galvanized steel	bar	6	0,98
CM-09-A304X-003	38	18	22	1,5	AISI 304 Stainless steel	bar	3	0,98
CM-09-A304X-006	38	18	22	1,5	AISI 304 Stainless steel	bar	6	0,98

CM10-CM11 Metallic profiles

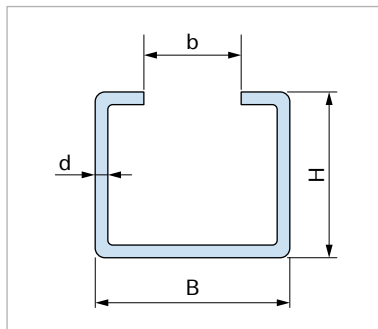
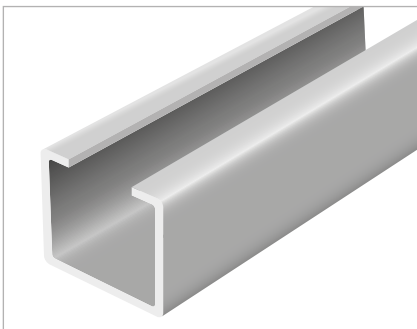

Application example

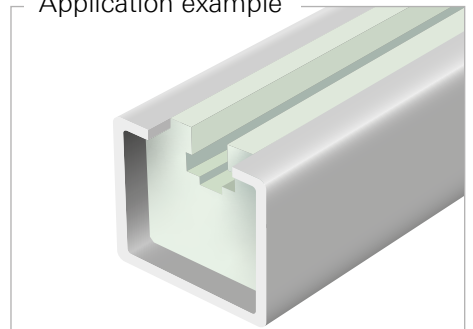

Habasit code	B	H	b	d	Material	Packaging unit	Total Length	Weight
	mm	mm	mm	mm			m	kg/m
CM-10-GALVX-003	30	24	20	1,5	Galvanized steel	bar	3	0,94
CM-10-GALVX-006	30	24	20	1,5	Galvanized steel	bar	6	0,94
CM-10-A304X-003	30	24	20	1,5	AISI 304 Stainless steel	bar	3	0,94
CM-10-A304X-006	30	24	20	1,5	AISI 304 Stainless steel	bar	6	0,94
CM-11-GALVX-003	45	40	31	1,5	Galvanized steel	bar	3	2,05
CM-11-GALVX-006	45	40	31	1,5	Galvanized steel	bar	6	2,05
CM-11-A304X-003	45	40	31	1,5	AISI 304 Stainless steel	bar	3	2,05
CM-11-A304X-006	45	40	31	1,5	AISI 304 Stainless steel	bar	6	2,05

CM14 Metallic profiles

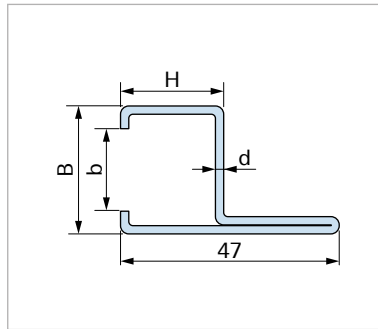
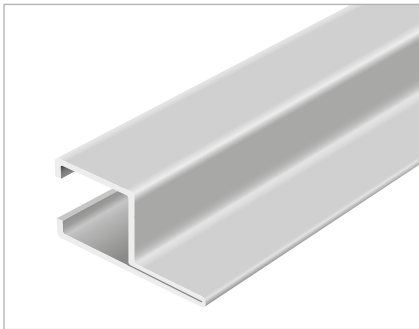

Application example

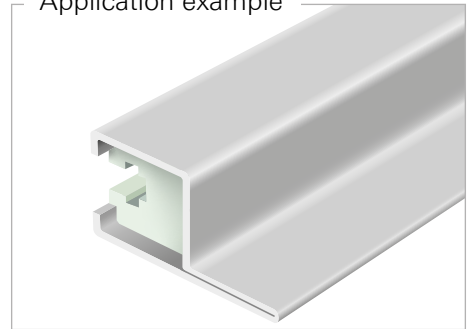

Habasit code	B	H	b	d	Material	Packaging unit	Total Length	Weight
	mm	mm	mm	mm			m	kg/m
CM-14-GALVX-003	31	25	20	2	Galvanized steel	bar	3	1,2
CM-14-GALVX-006	31	25	20	2	Galvanized steel	bar	6	1,2
CM-14-A304X-003	31	25	20	2	AISI 304 Stainless steel	bar	3	1,2
CM-14-A304X-006	31	25	20	2	AISI 304 Stainless steel	bar	6	1,2

CM15 Metallic profiles

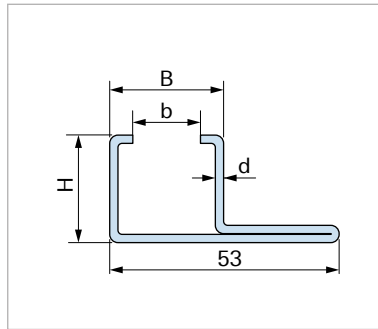
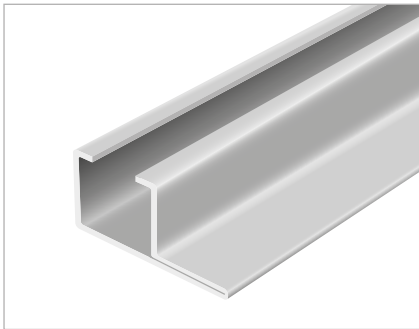

Application example

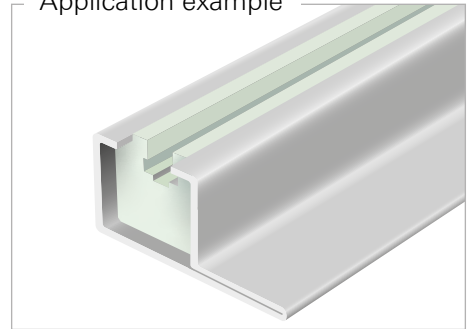

Habasit code	B	H	b	d	Material	Packaging unit	Total Length	Weight
	mm	mm	mm	mm			m	kg/m
CM-15-GALVX-003	31	25	20	2	Galvanized steel	bar	3	1,2
CM-15-GALVX-006	31	25	20	2	Galvanized steel	bar	6	1,2
CM-15-A304X-003	31	25	20	2	AISI 304 Stainless steel	bar	3	1,2
CM-15-A304X-006	31	25	20	2	AISI 304 Stainless steel	bar	6	1,2
CM-15-ALUMX-005	31	25	20	2,5	Aluminum	bar	5,05	0,83

Standard holes for CM14 / CM15

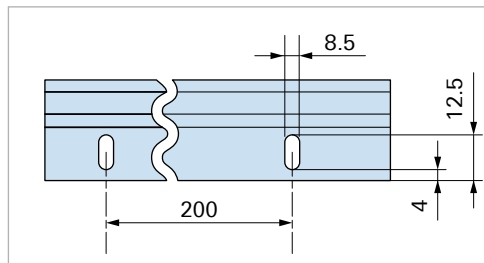

CM16 Metallic profiles

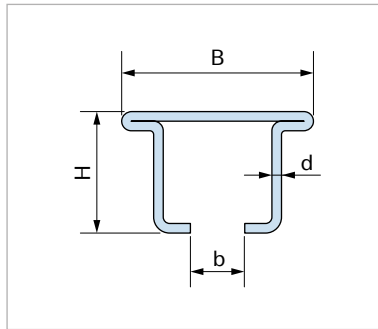
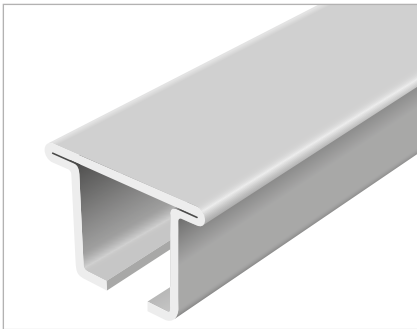

Application example

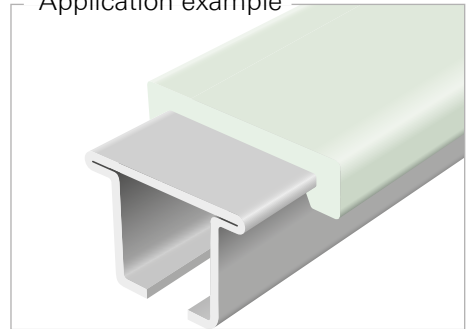

Habasit code	B	H	b	d	Material	Packaging unit	Total Length	Weight
	mm	mm	mm	mm			m	kg/m
CM-16-A304X-003	29,8	19	8,8	1,5	AISI 304 Stainless steel	bar	3	0,9
CM-16-A304X-006	29,8	19	8,8	1,5	AISI 304 Stainless steel	bar	6	0,9
CM-16-A430X-003	29,8	19	8,8	1,5	AISI 430 Stainless steel	bar	3	0,9
CM-16-A430X-006	29,8	19	8,8	1,5	AISI 430 Stainless steel	bar	6	0,9

FC-20 fixing clamps

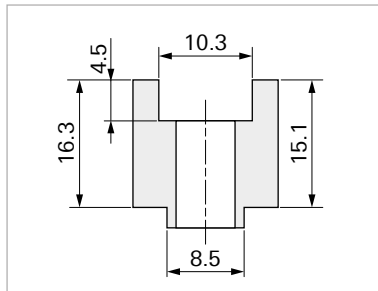
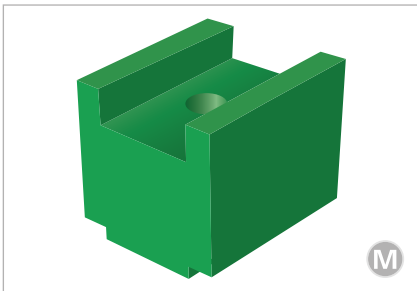

Application example

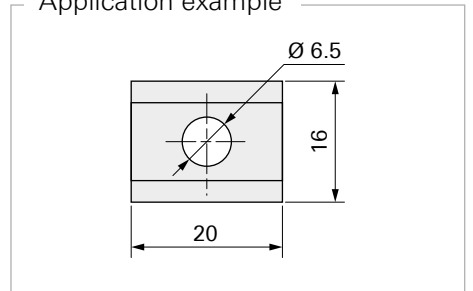

FC-50 fixing clamps

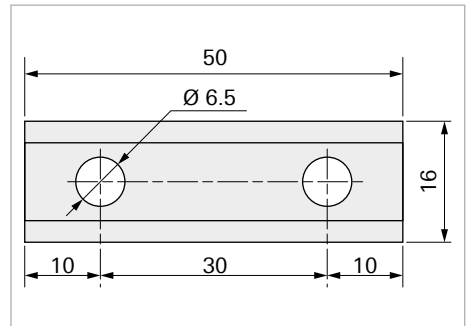
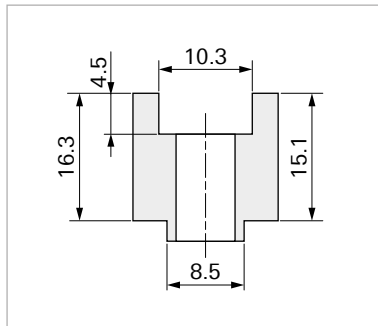
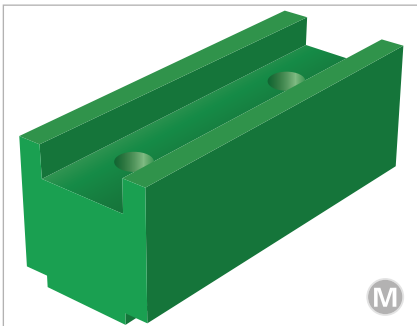

FC-20 data

Habasit code	Material	Color	Nr of clamps per box
FC-20-PE05W+FG	PE05	white <input type="checkbox"/>	200
FC-20-PE10B+RC	PE10	black <input type="checkbox"/>	200
FC-20-PE10G+RC	PE10	green <input type="checkbox"/>	200
FC-20-PA6GW	PA6	white <input type="checkbox"/>	200
FC-20-PA6GB	PA6	black <input type="checkbox"/>	200
FC-20-POMCW+FG	POM	white <input type="checkbox"/>	200
FC-20-POMCB	POM	black <input type="checkbox"/>	200

FC-50 data

Habasit code	Material	Color	Nr of clamps per box
FC-50-PE05W+FG	PE05	white <input type="checkbox"/>	100
FC-50-PE10B+RC	PE10	black <input type="checkbox"/>	100
FC-50-PE10G+RC	PE10	green <input type="checkbox"/>	100
FC-50-PA6GW	PA6	white <input type="checkbox"/>	100
FC-50-PA6GB	PA6	black <input type="checkbox"/>	100
FC-50-POMCW+FG	POM	white <input type="checkbox"/>	100
FC-50-POMCB	POM	black <input type="checkbox"/>	100







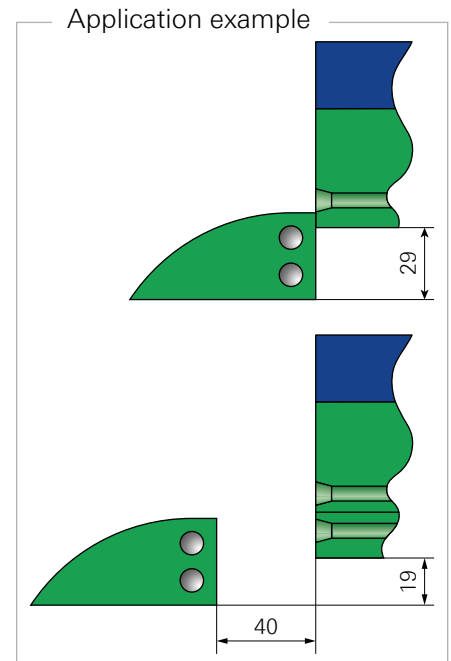
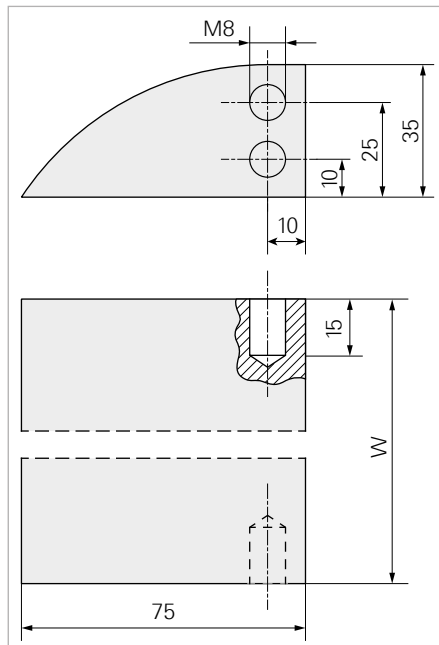
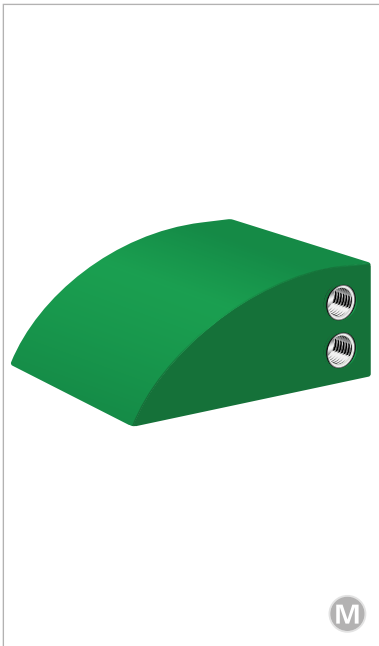







Extruded Machined

Black (non Food Grade) Natural white Green Cobalt blue

Return shoes



Habasit code	Chain	Nr of lanes	Material	Color	W
					mm
HP-RS-000001-PE40G	C880M/C1061 3.25"/3.30"	1	PE40G/Stainless steel	green ■	100
HP-RS-000002-PE40G	C880M 4.50"	1	PE40G/Stainless steel	green ■	129
HP-RS-000003-PE40G	C880M/C1061 3.25"/3.30"	2	PE40G/Stainless steel	green ■	185
HP-RS-000004-PE40G	C880M 4.50"	2	PE40G/Stainless steel	green ■	246

Condensed Material features	Extended material features	Old name	Habasisit material name (DoC)	Color	Sheets FOOD compliancy	Round Bars availability	Round Bars FOOD compliancy
PE Polyethylene HabiPLAST™							
High density PE (~300.000 molecular weight)	PEHD with a molecular weight in the range of 300'000 g/mol. Good performance with HabasisitLINK and HabaCHAIN materials in low demanding applications. Excellent chemical resistance. White and green limited resistance against UV light.	HabiPLAST HE/M	HabiPLAST-PE03-natwh	white 		X	
			HabiPLAST-PE03-black	black 		X	
			HabiPLAST-PE03-green	green 		X	
High density PE (~500.000 molecular weight)	PEHMW with a molecular weight in the range of 500'000 g/mol. Good performance with HabasisitLINK and HabaCHAIN materials. Excellent chemical resistance. Limited resistance against UV light.	HabiPLAST H/SA	HabiPLAST-PE05-natwh+FG	white 	YES		
			HabiPLAST-PE05-blue+FG	blue 	YES		
High density PE (~500.000 molecular weight), recycled	Recycled PEHMW with a molecular weight in the range of 500'000 g/mol. Should not be used for sliding applications with HabasisitLINK and HabaCHAIN materials.		HabiPLAST-PE05-black+RC	black 			
Ultra high molecular weight PE (~1.000.000), recycled, antistatic	Recycled PEUHMW with a molecular weight in the range of 1'000'000 g/mol and antistatic properties. Good performance with HabasisitLINK and HabaCHAIN materials.	HabiPLAST UHR/S	HabiPLAST-PE10-black+AR	black 		X	
Ultra high molecular weight PE (~1.000.000), recycled	Recycled PEUHMW with a molecular weight in the range of 1'000'000 g/mol. Good performance with HabasisitLINK and HabaCHAIN materials.	HabiPLAST UHR/S	HabiPLAST-PE10-green+RC	green 			
Ultra high molecular weight PE (min 4.000.000)	PEUHMW with a molecular weight higher than 4'000'000 g/mol. Sintered materials with good wear and friction properties. Suitable for high demanding applications. Good performance with HabasisitLINK and HabaCHAIN materials. Excellent chemical resistance. White and green limited resistance against UV light.	HabiPLAST UHV/S	HabiPLAST-PE40-black	black 			
			HabiPLAST-PE40-green	green 			
			HabiPLAST-PE40-natwh+FG	white 	YES	X	YES
Ultra high molecular weight PE (min 4.000.000), electroconductive	PEUHMW with a molecular weight higher than 4'000'000 g/mol. Conductive material with low friction values on conductive HabasisitLINK and HabaCHAIN materials.	HabiPLAST UHV/S-B NERA EL	HabiPLAST-PE40-black+EC	black 			
Ultra high molecular weight PE (min 4.000.000), with Molybdenum disulphide	PEUHMW with a molecular weight higher than 4'000'000 g/mol. Molybdenum filled material with good wear resistance against steel in wet and dry environment.	HabiPLAST UHV/S MOS2	HabiPLAST-PE40-black+MO	black 			
Ultra high molecular weight PE (min 8.000.000), low friction	PEUHMW with a molecular weight higher than 8'000'000 g/mol. Sintered materials with excellent wear resistance. Modified to have very low friction against steel. Excellent chemical resistance. Limited resistance against UV light.	HabiPLAST UHV/S S.PLUS	HabiPLAST-PE80-coblu+LF	coblu 			
Ultra high molecular weight PE (min 8.000.000), with glass balls	PEUHMW with a molecular weight higher than 8'000'000 g/mol. Glass balls reinforcement. Mainly used for high speed PET bottling guides.	HabiPLAST UHV/S PT	HabiPLAST-PE80-black+GB	black 			



Condensed Material features	Extended material features	Old name	Habasisit material name (DoC)	Color	Sheets FOOD compliance	Round Bars availability	Round Bars FOOD compliance
PE Polyethylene HabiPLAST™							
Ultra high molecular weight PE (min 8.000.000), electroconductive	PEUHMW with a molecular weight higher than 8'000'000 g/mol. For demanding applications where a low conductivity is needed.	HabiPLAST UHV/S PLUS-EL	HabiPLAST-PE80-black+EC	black 			
TP Polyethylene special Habasisit formulation TriboPlus®							
Ultra high molecular weight PE, low friction, low wear	Modified PEUHMW with very low friction and lowest wear rate with HabasisitLINK and HabaCHAIN materials in not abrasive applications.	TriboPlus	TriboPlus-TP40-coblue+FG	coblue 	YES		
Ultra high molecular weight PE, low friction, low wear, electroconductive	Modified PEUHMW with very low friction and lowest wear rate with HabasisitLINK and HabaCHAIN materials in not abrasive applications. With conductive properties.	TriboPlus FE	TriboPlus-TP40-black+FE	black 	YES		
PA Polyamide Habilon							
Extruded PA6	Extruded PA6 . Mainly used for machined parts like sprockets.	Habilon PA6/E	Habilon-PA6E-natwh	white 		X	
Cast PA6	Cast PA6 . Mainly used for machined parts like sprockets.	Habilon PA6/C	Habilon-PA6C-natwh	white 			
Cast PA6 heat stabilized	Modified cast PA6 , resistant to higher temperatures (Max 120 °C).	Habilon PA6 STABCAL	Habilon-PA6C-black+ET	black 		X	
Cast PA6, with Molybdenum disulphide	Molybdenum filled cast PA6 with good wear resistance against steel in dry environment.	Habilon PA6/C-MOS2	Habilon-PA6C-black+MO	black 			
Cast PA6, self-lubricating	Modified cast PA6 with very low friction and lowest wear rate with HabasisitLINK and HabaCHAIN materials in demanding applications.		Habilon-PA6C-gray+LF	gray 			
PA66, + 30% glass fibre	Glassfiber reinforced PA66 with high stiffness, high strength and high temperature resistance.	Habilon PA66/E-GF30	Habilon-PA66-black+G5	black 			
PET Polyethylene terephthalate Habipet							
PET	Very hard thermoplastic material, good performance with HabasisitLINK and HabaCHAIN materials in abrasive and wet applications.	Habipet PET	Habipet-PET-black	black 			
			Habipet-PET-natwh+FG	white 	YES	X	YES
PET low friction	Modified PET with very low friction and lowest wear rate. Very hard thermoplastic material, good performance with HabasisitLINK and HabaCHAIN materials in abrasive and wet applications.	Habipet PET CLS	Habipet-PET-gray+LF	gray 			
POM Polyoxymethylene Habital							
POM	Hard thermoplastic material for machined parts like sprockets. Squeaking in combination with POM belts	Habital POM	Habital-POM-black	black 			
			Habital-POM-natwh+FG	white 	YES	X	YES
			Habital-POM-coblue+FG	coblue 	YES		

Condensed Material features	Extended material features	Old name	Habasisit material name (DoC)	Color	Sheets FOOD compliance	Round Bars availability	Round Bars FOOD compliance
PP Polypropylene Habilene							
PP	Good hot water and chemical resistance.	Habilene PP	Habilene-PP-natwh	white <input type="checkbox"/>			
PTFE Polytetrafluorethylene Habiflour							
PTFE	Extreme good chemical resistance, none sticking properties.	Habiflour PTFE	Habiflour-PTFE-natwh+FG	white <input type="checkbox"/>	YES	X	YES
PTFE 25% glass fibre	Reinforced material with very good chemical resistance, none sticking properties, slightly improved wear resistance versus unfilled material.	HABIFLUOR PTFE+GF25	Habiflour-PTFE-natwh+G4	white <input type="checkbox"/>			
PVC Polyvinylchloride Habivit							
PVC	Good chemical resistance.	Habivit PVC/E	Habivit-PVC-natwh	white <input type="checkbox"/>		X	
			Habivit-PVC-gray	gray <input type="checkbox"/>		X	
			Habivit-PVC-black	black <input type="checkbox"/>			

Materials for machined parts							
Brand		HabiPLAST™					
Grade		PE05+RK	PE05+RC	PE40+MO	PE80+EC	PE80+GB	PE80+LF
Base		PEHMW		PEUHMW			
Density	g/cm ³	0,94	0,94	0,95	0,93	0,96	0,93
Thermal Nominal values							
Temperature range	°C	-150 to +80	-150 to +80	-70 to +65	-70 to +65	-70 to +65	-70 to +65
	°F	-238 to 176	-238 to 176	-94 to 150	-94 to 150	-94 to 150	-94 to 150
Coeff. of linear thermal expansion α	mm/(m×K)	0,2	0,2	0,2	0,2	0,2	0,2
	in/(ft×°F)	0,00133	0,00133	0,00133	0,00133	0,00133	0,00133
Mechanical Nominal values							
Tensile modulus	MPa	750	750	580	900	750	
Tensile strength	MPa	19	19	18	20	18	20
Tensile elongation	%	200	200	200	200	50	200
Charpy notched impact resistance	mJ/mm ²	90		120			
Ball hardness	MPa	34	34	40	42	33	30
Electrical Nominal values							
Volume resistivity	Ohm×cm			≥10 ¹²	≤10 ⁴	≥10 ¹⁴	≥10 ¹⁴
Surface resistivity	Ohm			≥10 ¹²	≤10 ⁴	≥10 ¹²	≥10 ¹³

Materials for machined parts											
Brand		Habilon					Habiflour		Habital	Habilen	Habitit
Grade		PA6E	PA6C	PA6C +ET	PA6C +MO	PA66 +GF	PTFE	PTFE +GF	POM	PP	PVC
Base		Polyamide / Nylon					PTFE		POM	PP	PVC
Density	g/cm ³	1,14	1,15	1,15	1,15	1,3	2,15	2,23	1,41	0,91	1,44
Thermal Nominal values											
Temperature range	°C	-30 to +100	-30 to +90	-30 to +120	-40 to +100	-20 to +110	-200 to +260	-200 to +260	-50 to +100	-18 to +105	0 to +60
	°F	-22 to +212	-22 to +194	-22 to +248	-40 to +212	-4 to +212	-238 to +500	-238 to +500	-58 to +212	0 to +221	32 to +140
Coeff. of linear thermal expansion α	mm(m×K)	0,12	0,08	0,08	0,11	0,05	0,13	0,1	0,12	0,16	0,2
	in/(ft×°F)	0,00080	0,00053	0,00053	0,00073	0,00033	0,00087	0,00067	0,00080	0,00107	0,00133
Mechanical Nominal values											
Tensile modulus	MPa	3300 (dry)	3600 (dry)	3500 (dry)	3200 (dry)	5000 (dry)		600	2800	1400	3300
Tensile strength	MPa	79 (dry)	88 (dry)	86 (dry)	82 (dry)	85 (dry)	24	17	66	32	58
Tensile elongation	%	130 (dry)	25 (dry)	25 (dry)	55 (dry)	5 (dry)	250	230	50	8	4
Charpy notched impact resistance	mJ/mm ²			3,5 (dry)		6 (dry)				7	
Ball hardness	MPa	155 (dry)	165 (dry)	165 (dry)	170 (dry)	165 (dry)			140	70	82
Electrical Nominal values											
Volume resistivity	Ohm×cm	≥10 ¹⁴	≥10 ¹⁴	≥10 ¹⁴	≥10 ¹⁴	≥10 ¹⁴	≥10 ¹⁸	≥10 ¹⁵	≥10 ¹⁴	≥10 ¹⁴	≥10 ¹³
Surface resistivity	Ohm	≥10 ¹⁴	≥10 ¹³	≥10 ¹³	≥10 ¹⁴	≥10 ¹³	≥10 ¹⁷	≥10 ¹⁵	≥10 ¹³	≥10 ¹⁴	≥10 ¹³

		HabasitLINK				HabaCHAIN			Steel Chains	HabiPLAST Belt support
		Modules	Rods	Sprocket		Chain	Sprocket			
				molded	machined		molded	machined		
Standard	General use	PP	PA	POM	POM	DP	GS	PA	carbon steel	PE40 PE10+RC
	General use, wet	PP	POM	POM	POM	DP	GS	PA	stainless	PE40 PE10+RC
	Chemical resistance	PP	PP	PP	PE40	PP		PE40	stainless	PE40 PE10+RC
	Impact, low temperature	PE	PE	POM	POM					PE40 TP40
	High load, dry	POM+JM	PA	PA	PA	LF	GS	PA		TP40 PA6C+LF
	High load, wet	POM+JM	PBT	POM	PA	LF	GS	PA		PE40 TP40
	High speed, dry	POM+LF	PA	PA	PA	NG, TS	ND	PA		TP40 PA6C+LF
	High speed, lubricated	POM	PBT	POM	PA	LF	ND	PA		PE40
	ESD (electrostatic dissipative)	POM+EC PP+EC PP+FC	PA	PA	PA	EC	GS	PA		TP40+FE PE40+EC
Specifically for meat	General use	PE POM	PE	POM	POM					PE40
	Cutting, low temperature	POM+IM POM+JM	PE	POM	POM					PE40 PET
Abrasive environment	Wet, up to 60 °C (140 °F)	PP	PBT, WHI Steel	PA, TPU	PA, PE40	PK	GS	PA		Steel
	Wet, up to 60 °C (140 °F), high load	POM	PBT, WHI Steel	PA, TPU	PA	PK	GS	PA		Steel
	Dry	PP	PA, Steel	PA, TPU	PA, PE40	WR	GS	PA		PA6C+LF
	Dry, high load	POM	PA, Steel	PA, TPU	PA	WR	GS	PA		PA6C+LF Steel
High temperatures	Wet, 60 °C to 105 °C (140 °F to 220 °F)	PP	PP	PP	Steel	PP	GS			Steel
	Dry, high load up to 93°C (200 °F)	POM	PA	PA	PA+GF Steel	LF	GS			PA6C+LF
	Elevated temperatures up to 130 °C (266 °F)	PA	PA	PA	PA+GF Steel	HT	CI			Steel
	Food contact and temperatures up to 145 °C (293 °F)	PA+GF	ST/Steel	ST	Steel	SS	CI			Steel
	Temperatures up to 170 °C (338 °F)	PA+HT	ST/Steel	ST	Steel	CS	CI			Steel
	Food contact and Temperatures up to 200 °C (392 °F)	ST	ST/Steel	ST	Steel	SS/SH/ SA	CI			Steel
Special	Fryer up to 205°C	ST	ST/Steel	ST	Steel					Steel
	Microwave unfreezing -30 to 40°C	PE	PE	POM	POM					PE40 / Steel
	Microwave cooking up to 100°C	PP	PP	POM	POM					PE40 / Steel
	Microwave baking 140 - 160°C	ST	ST	ST	Steel					Steel

		Cleandrive			Timing Belt			Extruded round belts, profiles and flat belts	HabiPLAST Belt support
		Belt	Sprocket		Belt		Sprocket		
			molded	machined	material	cord			
Standard	General use	TPU	POM	POM PE40	TPU 01	Steel	Aluminium	PVC, TPU	PE40 POM
	General use, wet	TPU	POM	POM PE40	TPU 05	Aramid	Aluminium	PVC, TPU-H	PE40 POM
	Chemical resistance	TPU	POM	POM PE40	TPU 04	Steel	Aluminium	PVC (TPU)	PE40 TP40
	Impact, low temperature	TPU	POM	POM PE40	TPU 01	Steel	Aluminium	TPU	PE40 TP40
	High load, dry	TPU	POM	POM PE40	TPU 01	Power steel	Aluminium	TPU	POM PA6C+LF
	High load, wet	TPU	POM	POM PE40	TPU 01	Power SS	Aluminium	TPU	POM
	High speed, dry	TPU	POM	POM PE40	TPU 01 + PA fabric	Aramid	Aluminium	TPU	TP40 PA6C+LF
	High speed, lubricated	TPU	POM	POM PE40	TPU 01	Aramid	Aluminium	TPU	PE40
	ESD (electrostatic dissipative)	TPU	POM	POM PE40	TPU 01+ antistatic fabric	Steel	Aluminium	TPU	TP40+FE PE40+EC
Specifically for meat	General use							TPU	PE40
Abrasive environment	Wet, up to 60 °C (140 °F)	TPU	POM	POM PE40	TPU 01 H	SS	Aluminium	TPU-H	POM
	Wet, up to 60 °C (140 °F), high load				TPU 01 H	Power SS	Aluminium	TPU-H	POM
	Dry	TPU	POM	POM PE40	TPU 01 H + PA fabric	Steel	Aluminium	TPU	PA6C+LF Steel sheet / round steel bars
	Dry, high load				TPU 01 H	Power steel	Aluminium	TPU	PA6C+LF Steel
High temperatures	Wet, 60 °C to 80 °C (140 °F to 176 °F)	TPU		PP					Round steel bars
	Dry, up to 80°C	TPU	POM	POM					PA6C+LF
	Elevated temperatures up to 130 °C (266 °F)				TPU 01 with heatmate cover	Steel	Aluminium		Steel

Brand	HabiPLAST™										Stainless Steel			
	PE03 PEHD		PE05 PEHMW		PE10+RC PE10+AR		PE40 PEUHMW		TP40+EC TP40			Habilon	Habipet	
Grade	PE03	PE05	PE10+RC	PE10+AR	PE40	PEUHMW	TP40+EC	TP40	TP40+FE	PA6C+LF	PETC	1,4301		
Base	PEHD	PEHMW			PEUHMW					Cast Nylon	PET			
Density	0,95	0,95	0,94	0,94	0,93	0,93	0,93	0,93	0,93	1,14	1,39			
Thermal														
Temperature range	-70 to +65	-70 to +65	-70 to +65	-70 to +65	-70 to +65	-70 to +65	-70 to +65	-70 to +65	-70 to +65	-30 to +90	-20 to +100			
	-94 to +150	-94 to +150	-94 to +150	-94 to +150	-94 to +150	-94 to +150	-94 to +150	-94 to +150	-94 to +150	-22 to +194	-4 to +212			
Coef. of linear thermal expansion α	0,2	0,2	0,2	0,2	0,2	0,2	0,2	0,2	0,2	0,08	0,07			
	in/(ft×°F)	0,00133	0,00133	0,00133	0,00133	0,00133	0,00133	0,00133	0,00133	0,00053	0,00047			
Mechanical														
Tensile modulus	1300	600	600	600	700	700	700	600	600	3150 (dry)	3500			
Tensile strength	23	27	17	17	18	18	18	24	24	80 (dry)	90			
Tensile elongation	50	200	200	200	200	200	200	140	140	25 (dry)	15			
Charpy notched impact resistance	105		80	80	170	140	140	260	260	4	2			
Ball hardness		45	38	37	38	38	38	30	150	170				
Electrical														
Volume resistivity	$\geq 10^{16}$	$\geq 10^{14}$	$\geq 10^{14}$	$\geq 10^{14}$	$\geq 10^{14}$	$\geq 10^{14}$	$\geq 10^{14}$	$\geq 10^{14}$	$\leq 10^6$	$\geq 10^{14}$	$\geq 10^{14}$	$\geq 10^{14}$		
Surface resistivity	$\geq 10^{13}$	$\geq 10^{13}$	$\geq 10^{13}$	$\geq 10^{13}$	$\geq 10^{13}$	$\geq 10^{13}$	$\geq 10^{13}$	$\geq 10^{13}$	$\leq 10^6$	$\geq 10^{12}$	$\geq 10^{13}$	$\geq 10^{13}$		
Coefficient of friction and wear rate (dry and clean)														
HabasitLINK® PBT HabaCHAIN® NP	dry				0,24	B	A+	0,25	A++	0,15	A++	0,25	0,76	0,5
	wear rate ²													C
HabasitLINK® POM HabasitLINK® POM+AS HabaCHAIN® DP	dry	0,26		0,24	0,24	B	A	0,22	A++	0,19	A++	0,18	0,27	0,39
	wear rate ²	B												B
	wet					0,15	A++	0,15	A++	0,12	A++			0,31
	wear rate ²					A++	A+	A++	A++	A++	A++			C
HabasitLINK® POM+DX HabasitLINK® POM+EC HabaCHAIN® EC	wet					0,23	B	0,22	B	0,22				0,34
	wear rate ²					B								C
	dry					0,33	A	0,24	A++	0,19			0,47	0,64
	wear rate ²					A							C	C
HabasitLINK® POM+LF HabaCHAIN® LF	dry				0,22		A+	0,22	A++	0,21	0,22	0,22	0,23	0,44
	wear rate ²													C
	wet													0,32
	wear rate ²													C
HabasitLINK® POM+PK HabaCHAIN® PK	dry				0,25	A++	A++	0,24	A++	0,17				0,33
	wear rate ²													C
	wet					0,22	A++	0,22	A++	0,15	0,15			0,22
	wear rate ²													B
HabasitLINK® PP HabasitLINK® PP+AS	wet					0,23	A++	0,23	A++	0,16				0,23
	wear rate ²					A+								B
	dry	0,21		0,24	0,24	A	A++	0,25	0,16	0,22	0,29	0,39	0,6	
	wear rate ²					A	A++	A++	A++	A++	C	C	C	



HabiPLAST™ materials for sliding / tribological applications



Coefficient of friction and wear rate (dry and clean)		Nominal values				
HabasitLINK® PP	wet friction ³		0,21		0,16	
	abrasive wear rate ²		B		A+	0,30
HabasitLINK® PP+AS	wet friction ¹					
	abrasive wear rate ²					
HabasitLINK® PP+EC	dry wear rate ¹		0,24	0,21		0,58
	dry wear rate ²			A+	A++	B
HabasitLINK® PP+FC	dry wear rate ¹			0,24		0,51
	dry wear rate ²			A+	A++	C
HabasitLINK® PP+FR	dry friction ¹		0,23	0,25	0,18	0,37
	dry wear rate ²			A	A++	B
HabasitLINK® PA	dry friction ¹	0,32	0,32	0,31	0,18	0,55
	dry wear rate ²			A+	A++	C
HabaCHAIN® NY	wet friction ³		0,14		0,14	0,45
	abrasive wear rate ²		B		A	C
HabasitLINK® PA+FRF	dry friction ¹		0,33		0,22	0,48
	dry wear rate ²		A++		A++	C
HabasitLINK® PA+GF	wet friction ³		0,14			0,27
	wet wear rate ²		A++			C
HabasitLINK® PE	abrasive wear rate ²		0,16		0,16	0,34
	dry friction ¹		A		B	C
HabasitLINK® WHI	dry wear rate ²		0,28		0,19	0,45
	wet friction ³		A		A+	B
HabaCHAIN® PT	abrasive wear rate ²		0,13			0,33
	dry friction ¹		A			C
HabaCHAIN® TS	wet wear rate ²		0,38		0,25	0,24
	dry friction ¹		C		B	C
HabaCHAIN® NG	dry wear rate ²		0,21	0,15	0,12	0,84
	wet friction ³		A	A++	A+	C
HabaCHAIN® PP	wet wear rate ²		0,15	0,15	0,13	0,40
	dry friction ¹		A++	A++	A++	C
HabaCHAIN® HT	wet friction ³		0,20		0,19	0,42
	abrasive wear rate ²		B		B	C
Stainless Steel 1.4301	dry friction ¹		0,25	0,17	0,17	
	wet wear rate ²		B	A+	A++	
Stainless Steel 1.4301	dry friction ¹		0,23	0,15	0,15	
	wet wear rate ²		C	A++	A++	
Stainless Steel 1.4301	dry friction ¹		0,24	0,18	0,18	
	wet wear rate ²		A	A++	A++	
Stainless Steel 1.4301	dry friction ¹		0,23	0,25	0,16	0,6
	wet wear rate ²		C	A++	C	C
Stainless Steel 1.4301	dry friction ¹		0,28	0,19	0,19	0,45
	wet wear rate ²		A	A++	C	B
Stainless Steel 1.4301	dry friction ¹		0,27	0,13	0,13	
	wet wear rate ²		A+	A++	A++	

¹measured on a test conveyor with 1500 kg/m² load, speed range 5 – 15 m/min, test distance 800 km

²measured on a pin on disk test, total wear rate of pin and disk together

³measured on a pin on disk test during wear test

Wear rate

A++ = Best performance

A+ = Good Performance

A = Standard combination

B = Acceptable but not recommended

C = Bad solution - do not use

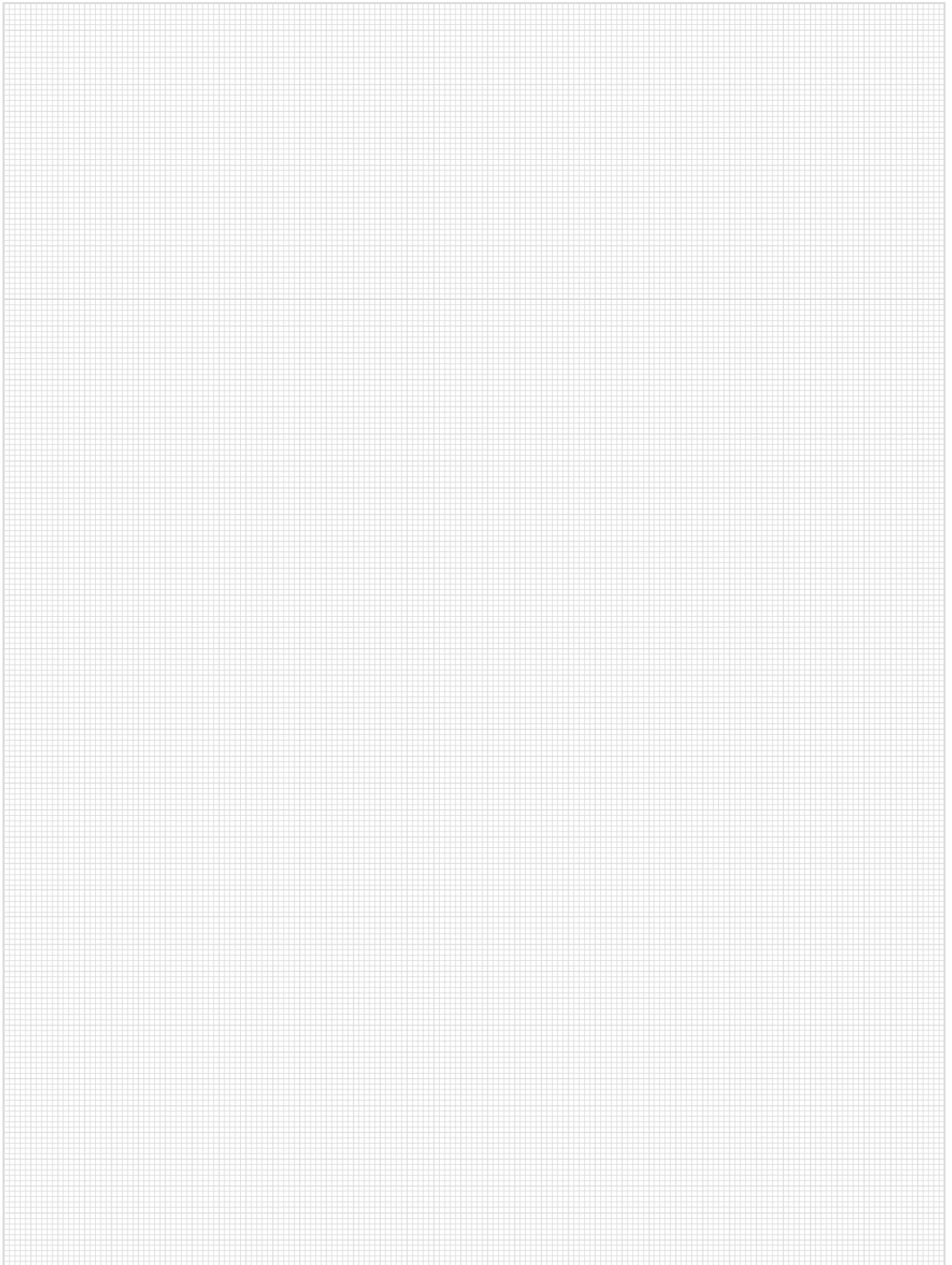

Customers first

Your success is our goal. This why we don't just offer products, we provide solutions. As committed partners to our customers, we are dedicated to sharing our knowledge and delivering full support.

Since our foundation in 1946, Habasit has been finding ways to meet each customer's specific needs in every application. This is what differentiates us as the No. 1 worldwide belting provider in the industry today.



Comprehensive consulting and technical support

Profit from the best consulting and technical support in the lightweight belting industry. Local experts are always available to assist you with your belting needs. The Habasit team is proud to provide the highest level of support, together with top-quality products that have led the global market for decades.



Belt selection and calculation assistance

We are always glad to help you select the most suitable belt for any application. We now also provide the free online tool 'SeleCalc' that makes it easy to make selections and calculations yourself. Simply register online at selecalc.habasit.com.



Fabrication, assembly and local installation services

As a full-service belting provider, we offer joining and assembly services either at our own locations or directly on your equipment.



Habasit has over 30 affiliates worldwide, each with its own inventory, fabrication, assembly and service facilities.

Together with representative offices and numerous qualified distributors, we can react quickly and efficiently to meet all your needs.



Customer training programs

To ensure the optimal performance and maximum lifespan of all our products, we offer training programs and various support tools. These include procedures for fabrication, installation, assembly, maintenance and belt repair, all of which take place at a Habasit site or at your location.



Belt monitoring, inspections, analyses and process optimization proposals

We organize and handle belt maintenance, inspections, analyses and surveys at customer sites. Upon request, we are ready to develop optimization proposals to ensure you're getting maximum value from your machinery and process output.

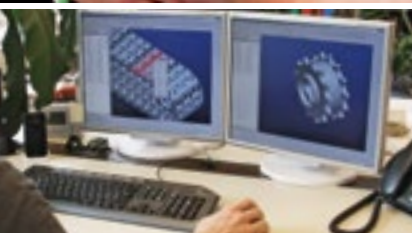

Design assistance for customized solutions

Habasit believes in building partnerships with our customers. Our engineering team will work closely with your engineers on joint design developments from initial design to final implementation. This expert service can be invaluable for projects involving new technologies or large-scale modifications and adaptations.

Australia

Habasisit Australia Pty Ltd.
Silverwater, Sydney
Phone: +61 1300 945 455
www.habasisit.com.au

Austria

Habasisit GmbH, Wiener Neudorf
Phone: +43 1 690 66
www.habasisit.at

Belgium & Luxembourg

Habasisit Belgium N.V., Zaventem
Phone: +32 27 250 430
www.habasisit.be | habasisit.lu

Brazil

Habasisit do Brasil, Barueri - SP
Phone: +55 11 4789 9022
www.habasisit.com.br

Canada

Habasisit Canada Ltd., Oakville
Phone: +1 905 827 41 31
www.habasisit.ca

China

Habasisit East Asia Ltd.
Fotan, Shatin, N.T., Hong Kong
Phone: +852 2145 0150
www.habasisit.com.hk

Habasisit (Shanghai) Co. Ltd.
Shanghai
Phone: +8621 5488 1218
www.habasisit.com.cn

France

Habasisit France SAS, Mulhouse
Phone: +33 3 89 33 89 03
www.habasisit.fr

Germany

Habasisit GmbH, Eppertshausen
Phone: +49 6071 969 0
www.habasisit.de

India

Habasisit India, Coimbatore
Phone: +91 422 666 78 00
www.habasisit.in

Italy

Habasisit Italiana SpA
Customer Care: 0438 911333
For int. calls: +39 0438 911444
www.habasisit.it

Japan

Habasisit Nippon Co., Ltd., Tokyo
Phone: +81 120 07 6339
www.habasisit.co.jp

Korea (Republic of)

Habasisit Korea Ltd., Seongnam
Phone: +82 31 737 9370
www.habasisit.co.kr

Mexico

Habasisit Rocua, Zapopan
Phone: +52 33 3824 2358
www.habasisitrocua.mx

Netherlands

Habasisit Netherlands BV, Nijkerk
Phone: +31 332 472 030
www.habasisit.nl

New Zealand

Habasisit New Zealand Pty Ltd.
Auckland
Phone: 0800 000 070
www.habasisit.co.nz

Nordic countries

Habasisit AB, Hindås, Sweden
Phone: +46 301 226 00
www.habasisit.se

Poland

Habasisit Polska Sp. z o.o.
Dąbrowa Górnicza
Phone: +48 32 639 02 40
www.habasisit.pl

Russia

OOO Habasisit Ltd.
Moscow Region
Phone: +7 495 966 1566
www.habasisit.ru

Singapore

Habasisit Far East Pte Ltd.
Singapore
Phone: +65 6862 5566
www.habasisit.com.sg

South Africa

Habasisit South Africa Pty Ltd.
Gauteng
Phone: +27 10 001 6770
www.habasisit.co.za

Spain

Habasisit Hispánica S.A.
Barberá del Vallés
Phone: +34 937 191 912
www.habasisit.es

Switzerland

Habasisit GmbH, Reinach
Phone: +41 61 577 51 00
www.habasisit.ch

Taiwan

Habasisit (Taiwan) Ltd.
New Taipei City
Phone: +886 2 2267 0538
www.habasisit.com.tw

Turkey

Habasisit Kayis San.
Ve Tic. Ltd. Sti., Istanbul
Phone: +90 444 70 43
www.habasisit.com.tr

Ukraine

Habasisit Ukraine LLC., Kyiv
Phone: +38 044 290 88 99
www.habasisit.ua

United Kingdom & Ireland

Habasisit UK Ltd., Elland
Phone: +44 333 207 6570
www.habasisit.co.uk

USA

Habasisit America
Suwanee, Georgia
Phone: +1 800 458 6431
www.habasisitamerica.com

Habasisit International AG

Römerstrasse 1
CH-4153 Reinach, Switzerland
Phone +41 61 715 15 15
Fax +41 61 715 15 55
www.habasisit.com

Registered trademarks
Copyright Habasisit International AG
Subject to alterations
4097BRO.VPR-en0621HQ

This **disclaimer** is made by and on behalf of Habasisit and its affiliated companies, directors, employees, agents and contractors (hereinafter collectively "HABASIT") with respect to the products referred to herein (the "Products").

SAFETY WARNINGS SHOULD BE READ CAREFULLY AND ANY RECOMMENDED SAFETY PRECAUTIONS BE FOLLOWED STRICTLY! Please refer to the Safety Warnings herein, in the Habasisit catalogue as well as installation and operating manuals.

All indications / information as to the application, use and performance of the Products are recommendations provided with due diligence and care, but no representations or warranties of any kind are made as to their completeness, accuracy or suitability for a particular purpose. The data provided herein are based on laboratory application with small-scale test equipment, running at standard conditions, and do not necessarily match product performance in industrial use. New knowledge and experience may lead to re-assessments and modifications within a short period of time and without prior notice.

EXCEPT AS EXPLICITLY WARRANTED BY HABASIT, WHICH WARRANTIES ARE EXCLUSIVE AND IN LIEU OF ALL OTHER WARRANTIES, EXPRESS OR IMPLIED, THE PRODUCTS ARE PROVIDED "AS IS". HABASIT DISCLAIMS ALL OTHER WARRANTIES, EITHER EXPRESS OR IMPLIED, INCLUDING, BUT NOT LIMITED TO, IMPLIED WARRANTIES OF MERCHANTABILITY, FITNESS FOR A PARTICULAR PURPOSE, NON-INFRINGEMENT, OR ARISING FROM A COURSE OF DEALING, USAGE, OR TRADE PRACTICE, ALL OF WHICH ARE HEREBY EXCLUDED TO THE EXTENT ALLOWED BY APPLICABLE LAW. BECAUSE CONDITIONS OF USE IN INDUSTRIAL APPLICATION ARE OUTSIDE OF HABASIT'S CONTROL, HABASIT DOES NOT ASSUME ANY LIABILITY CONCERNING THE SUITABILITY AND PROCESS ABILITY OF THE PRODUCTS, INCLUDING INDICATIONS ON PROCESS RESULTS AND OUTPUT.