

HabaCHAIN® Engineering Guide

Habasit – Solutions in motion

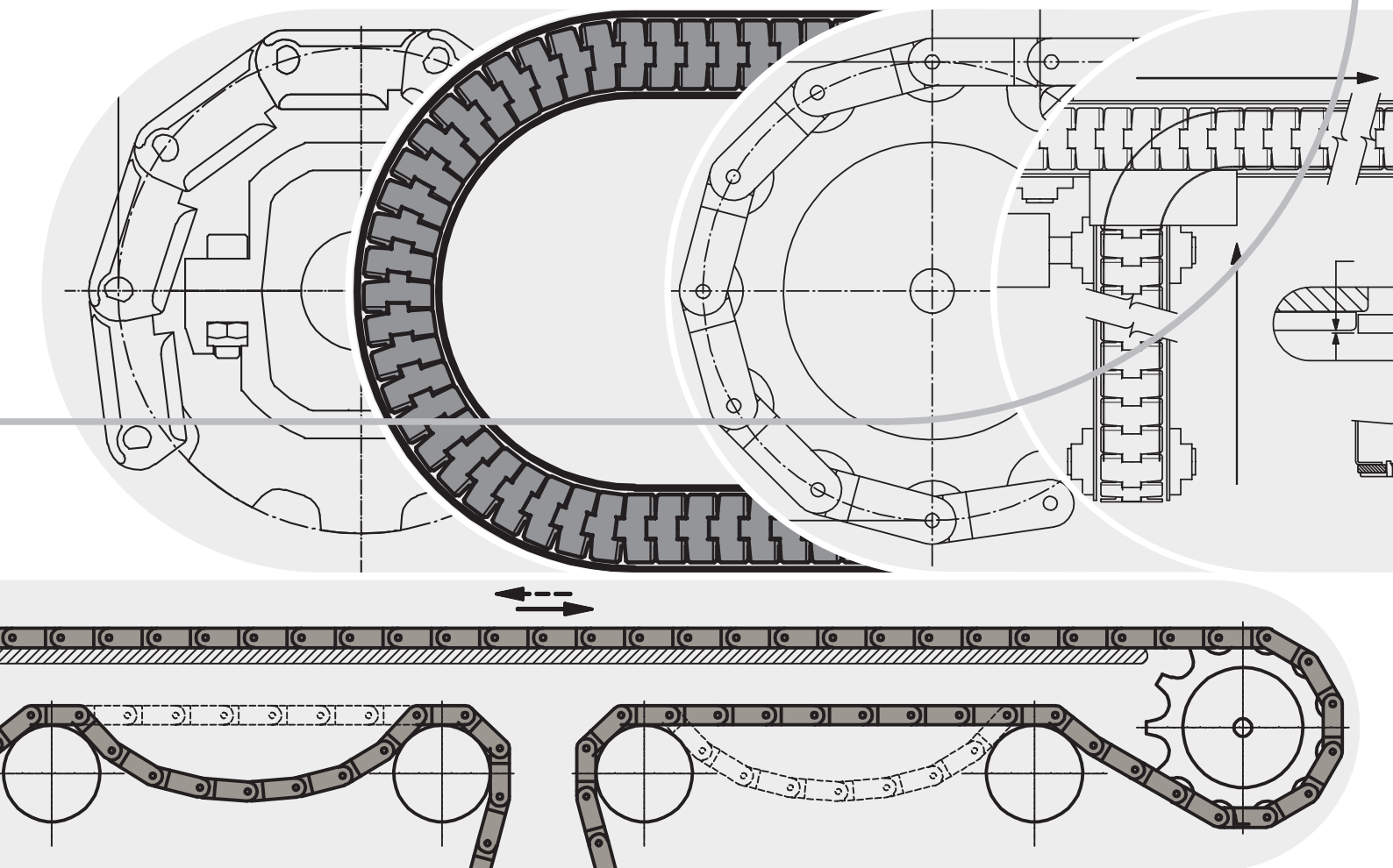

This **disclaimer** is made by and on behalf of Habasit and its affiliated companies, directors, employees, agents and contractors (hereinafter collectively "HABASIT") with respect to the products referred to herein (the "Products"). SAFETY WARNINGS SHOULD BE READ CAREFULLY AND ANY RECOMMENDED SAFETY PRECAUTIONS BE FOLLOWED STRICTLY! Please refer to the Safety Warnings herein, in the Habasit catalogue as well as installation and operating manuals. All indications/information as to the application, use and performance of the Products are recommendations provided with due diligence and care, but no representations or warranties of any kind are made as to their completeness, accuracy or suitability for a particular purpose. The data provided herein are based on laboratory application with small-scale test equipment, running at standard conditions, and do not necessarily match product performance in industrial use. New knowledge and experience may lead to re-assessments and modifications within a short period of time and without prior notice.

EXCEPT AS EXPLICITLY WARRANTED BY HABASIT, WHICH WARRANTIES ARE EXCLUSIVE AND IN LIEU OF ALL OTHER WARRANTIES, EXPRESS OR IMPLIED, THE PRODUCTS ARE PROVIDED "AS IS." HABASIT DISCLAIMS ALL OTHER WARRANTIES, EITHER EXPRESS OR IMPLIED, INCLUDING, BUT NOT LIMITED TO, IMPLIED WARRANTIES OF MERCHANTABILITY, FITNESS FOR A PARTICULAR PURPOSE, NON-INFRINGEMENT, OR ARISING FROM A COURSE OF DEALING, USAGE, OR TRADE PRACTICE, ALL OF WHICH ARE HEREBY EXCLUDED TO THE EXTENT ALLOWED BY APPLICABLE LAW. BECAUSE CONDITIONS OF USE IN INDUSTRIAL APPLICATION ARE OUTSIDE OF HABASIT'S CONTROL, HABASIT DOES NOT ASSUME ANY LIABILITY CONCERNING THE SUITABILITY AND PROCESS ABILITY OF THE PRODUCTS, INCLUDING INDICATIONS ON PROCESS RESULTS AND OUTPUT.

Warning

Habasit belts and chains are made of various plastics that WILL BURN if exposed to sparks, incendiaries, open flame or excessive heat. NEVER expose plastic belts and chains to a potential source of ignition. Flames resulting from burning plastics may emit TOXIC SMOKE and gases as well as cause SERIOUS INJURIES and PROPERTY DAMAGE.

Introduction			
The features of Habachain®	4	Habachain® with Habiplast™ profiles	42
Product range information	5	• Wear strip suitability evaluation	44
Your benefits at a glance	6	• Steel profile thickness	46
Product range overview		• Wear strip suitability of chain type	47
• Slat Top chains (plastic)	7	• Wear strip fixation	48
• Low back pressure chains LBP	7	• Wear strip length	50
• Slat Top chains (steel)	7	• Materials	51
• Flexi chains	8	Chain calculation procedure	52
• Snap-on chains	8	Appendix	
• Multiflex chains	8	List of abbreviations	53
• Case chains	9	Conversion of units metric / imperial	55
• Sprockets and idlers	9	Material properties – coefficient of friction	56
Material overview	10	Material properties – coefficient of thermal expansion	58
Design guide		Glossary of terms	59
Habachain® conveyor components	15	Trouble shooting guide	61
Conveyor layout	17	Chemical resistance	
• Straight running configuration	17	• Plastics	64
• Radius configuration	17	• Steel	69
• Conveyor length	18	Safety information	70
• Elevating conveyors	19	Index	71
• Transfers	20	The Habasit solution	73
• Specialty conveyors	23	Contacts	74
Mechanical design	25		
• Sprocket and idler positioning	25		
• Roller chain sprockets	30		
• Drive and tensioning construction	31		
• Transport side	34		
• Return side	39		

Introduction

The features of HabaCHAIN®

Wide product range meeting industrial requirements

The HabaCHAIN® range provides optimum solutions with its wide choice of product types. The range includes:

- Slat Top plastic and steel
- Low Back Pressure (LBP)
- Flexi
- Snap-on
- Multiflex
- Case Chains
- Accessories and attachments to enhance the product range

State-of-art materials

Habasisit's understanding of the industry has developed a full material portfolio to meet most industrial requirements. The range includes a series of POM (acetal) materials embracing standard POM (DP) and low friction POM (LF) and (PT). Extra low friction material (TS) and (NG) are available as well. A full range of specialty materials to meet demanding applications are also available and listed in the material overview starting on page 10.

Multi-Hub sprockets and idlers

Habasisit developed a new system of split sprockets and idlers called Multi-Hub. Interchangeable hub inserts in various diameters with or without keyway and sprocket, or idler rims in two different materials reduce the inventory needed by our customers. With this innovative Multi-Hub system it is possible to combine a noise dampening sprocket rim with a stiff and wear resistant hub. The customized choice of

materials and high fabrication accuracy ensure long lifetime and well as optimized power transmission.

Low Back Pressure (LBP) chains

In order to provide a solution for accumulation applications in packaging and material handling industries, Habasisit introduced a series of chains with patented low back pressure rollers. This chain design enables easy replacement or cleaning of rollers as well as an option to use sliding blocks in between rollers as a cost efficient measure.

HabiPLAST™ profiles, guide, and corner tracks

Complementing the HabaCHAIN® product range, Habasisit offers a range of HabiPLAST™ profiles, guides, wear strips and corner tracks manufactured in a highly modern plant with proprietary technology. This range of products offers great wear resistance, low coefficient of friction, low noise, good impact resistance, high chemical and corrosion resistance as well as easy assembly, along with possibility to offer customized solutions. We offer magnetic corner tracks for use with special chains designed for running in them and lifting out for easy maintenance.

Introduction

Product range information

Product information on www.habasisit.com

Please visit our website for in-depth and always up-to-date information on products and applications and for detailed technical data.

Product information in brochures

HabaCHAIN® slat and conveyor chains are produced to the highest standards. The range comprises more than 65 chain types, with new types constantly under development to always ensure the most advanced offer. For detailed product information about our chains refer to the related brochures:
4122 HabaCHAIN Product Overview
4185 HabaCHAIN Product Guide

Features and benefits



Key features	Your benefits
<ul style="list-style-type: none"> • High tensile strength 	<ul style="list-style-type: none"> → Less downtime, maximize conveyor line layouts
<ul style="list-style-type: none"> • Low friction materials 	<ul style="list-style-type: none"> → Excellent for high speed applications
<ul style="list-style-type: none"> • Bevel edges 	<ul style="list-style-type: none"> → Product stability over multiple strand conveyance
<ul style="list-style-type: none"> • High friction inserts 	<ul style="list-style-type: none"> → Unique product conveying solutions
<ul style="list-style-type: none"> • Wide range of specialty materials 	<ul style="list-style-type: none"> → Total coverage for all your application needs

Innovative patented products

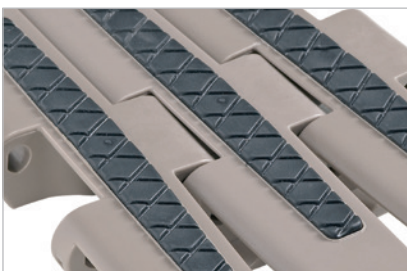

We offer	You get
<ul style="list-style-type: none"> • Multi-hub sprockets and idler design 	<ul style="list-style-type: none"> → Unique design concept allows for separating the tooth segment from the hub/bore insert → This provides flexibility to optimize inventory while reducing carrying cost
<ul style="list-style-type: none"> • C7100 chain design 	<ul style="list-style-type: none"> → Increased versatility through a two-piece chain
<ul style="list-style-type: none"> • Low-backline pressure (LBP) solution 	<ul style="list-style-type: none"> → Reduced back pressure → Noise reduction → Better load stability → Reduced vibration.
<ul style="list-style-type: none"> • Insert of special sliding block for LBPs in place of the intermediate shaft 	<ul style="list-style-type: none"> → Better stability → Noise reduction → Low product residual push
<ul style="list-style-type: none"> • Unique magnetic solution for improved tracking 	<ul style="list-style-type: none"> → Noise reduction → Better cleanability

Slat Top chains (plastic)



770T (radius)



820 (straight)

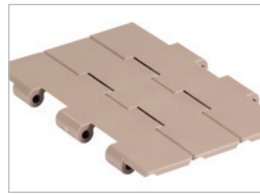

821 (straight)



828 (straight)



831 (straight)

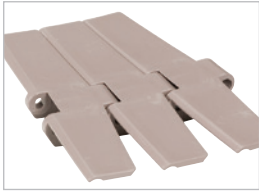

879B (radius)



879T (radius)



880B (radius)



880LJ (radius)



880J (radius)



880T (radius)



880M (radius)



882B (radius)



882T (radius)



882TG (radius)



890T (radius)



1061M (radius)



1061T (radius)



1071B (radius)

Low back pressure chains LBP



LBP 821 (straight)



LBP 821 SB (straight)



LBP 882T (radius)



LBP 882T SB (radius)

Slat Top chains (steel)



800 (straight)



810 (straight)



881B (radius)



881T (radius)

Flexi chains



7100HA

Snap-on chains



843 (straight)



843C (straight)

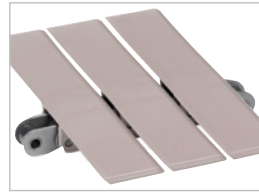

863 (straight)

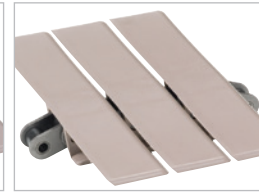

863T (straight)



963 (straight)



963T (straight)



1843T (radius)



1873T (radius)



1873T-T (straight)



1873-D1 (radius)

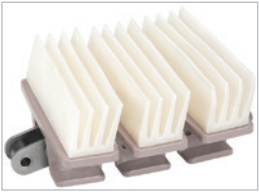

1873-L4 (radius)



1874T (radius)



3873T (radius)

Multiflex chains



1700 (radius)



1701T (radius)



1702 (radius)

Case chains



40P (straight)



60P (straight)



600 (radius)



601 (radius)



610T (radius)



611T (radius)



611TE (radius)



1100 (straight)



1110T (radius)



1150 (straight)



1151T (radius)



1200 (straight)



1201AB (straight)



1210T (radius)



1211TB (radius)



1250 (straight)



1251T (radius)



1400 (radius)



1410T (radius)



3200 (straight)



3210T (radius)



NH78 (straight)

Sprockets and idlers



Split sprockets
Machined split sprockets



Retainer rings
For lateral fixation of sprockets and idlers on round and square shafts.



Multi-Hub sprockets and idlers
Different split sprockets or idlers can be combined with different hub inserts.



Solid sprockets and idlers
Machined or molded solid sprockets and idlers. Made of plastics or steel.

Plastic chains

HabaCHAIN® products are made of high quality plastics from the best raw material producers. Habasit's program of studying material applications ensures the most suitable plastic type material for the particular conditions, as listed below:

Plastic chains – Standard chain materials				
Material	Description	Density [g/cm ³]	Temperature range	Standard color
DP	Standard POM (Acetal) ¹⁾ with good strength and good coefficient of friction. Entry level material for standard or low speed applications.	1.42	Dry conditions: -40 °C to +93 °C (-40 °F to +200 °F) Wet conditions: -40 °C to +60 °C (-40 °F to +140 °F)	Gray
LF	Low-friction POM (Acetal) ¹⁾ with high strength and good abrasion resistance. Suitable for high speed applications. Food contact approved.	1.42	Dry conditions: -40 °C to +93 °C (-40 °F to +200 °F) Wet conditions: -40 °C to +60 °C (-40 °F to +140 °F)	Light brown for Flexi Chains: White
PT	Low-friction POM (Acetal) ¹⁾ The material shows a low coefficient of friction, high strength and good abrasion resistance. Suitable for high speed applications with reduced lubrication	1.43	Dry conditions: -40 °C to +93 °C (-40 °F to +200 °F) Wet conditions: -40 °C to +60 °C (-40 °F to +140 °F)	Gray-brown for Flexi Chains: White
TS	Extra low-friction POM (Acetal) ¹⁾ with special self-lubricating agents. This material has the lowest friction values and highest PxV (load and speed) limit.	1.43	Dry conditions: -40 °C to +93 °C (-40 °F to +200 °F) Wet conditions: -40 °C to +60 °C (-40 °F to +140 °F)	Silver
NG	Extra low friction PBT material with good strength and very good abrasion resistance. Suitable for high speed, dry running applications. Should be used in combination with a high performance corner track.	1.34	Dry conditions: -40 °C to +120 °C (-40 °F to +248 °F) Wet conditions: -40 °C to +50 °C (-40 °F to +122 °F)	Gray

Plastic chains – Special chain materials				
Material	Description	Density [g/cm ³]	Temperature range	Standard color
For special materials, strength reduction and dimensional variation to be expected. Please consult with Habasit Engineering.				
PK	Extra wear-resistant aramidic fiber-filled POM (Acetal) ¹⁾ . The special formulation ensures good wear resistance and a low coefficient of friction, especially for abrasive, wet or dry running applications.	1.41	Dry conditions: -40 °C to +93 °C (-40 °F to +200 °F) Wet conditions: -40 °C to +66 °C (-40 °F to +151 °F)	Dark gray
EC	POM (Acetal) ¹⁾ with an electrical surface resistivity below 50.000 Ohm/sq (DIN/EN 1637). Material has high strength and a good coefficient of friction. Especially for applications where chain charge-up must be avoided. To be used with a conductive wear strip.	1.42	Dry conditions: -40 °C to +93 °C (-40 °F to +200 °F)	Black

¹⁾ POM (Acetal) generally shows good resistance to oil and alkalines and has a cut-resistant surface.

Plastic chains – Special chain materials				
Material	Description	Density [g/cm ³]	Temperature range	Standard color
DE	POM (Acetal) ¹⁾ with a special additive to ensure the material is detectable for metal and X-ray systems.	1.67	Dry conditions: -40 °C to +93 °C (-40 °F to +200 °F) Wet conditions: -40 °C to +66 °C (-40 °F to +151 °F)	Blue
NY	PA with high strength and abrasion resistance. Material has very good long-term heat resistance. Suitable for high load, dry conditions and elevated temperatures. Flammability rating UL94 V2	1.14	Dry conditions: -46 °C to +118 °C short-term +135 °C (-50 °F to +245 °F short-term +275 °F) Wet conditions: not recommended	Dark gray
WR	Extra wear-resistant PA for dry and abrasive applications (glass). Higher wear resistance than NY with a low coefficient of friction. When using this material, it is necessary to use a synthetic lubricating agent (no water).	1.35	Dry conditions: -18 °C to +82 °C (0 °F to +180 °F) Wet conditions: not recommended	Black
HT	Reinforced PA with very high strength and toughness. Suitable for high loads, dry conditions, at elevated temperatures. Flammability rating UL94 HB.	1.37	Dry conditions: -40 °C to +145 °C short-term +175 °C (-40 °F to +293 °F short-term +347 °F) Wet conditions: not recommended	Black
NP	PBT with good strength and low coefficient of friction. Developed for conveying applications in the tobacco industry.	1.30	Dry conditions: -40 °C to +120 °C (-40 °F to +248 °F) Wet conditions: -40 °C to +50 °C (-40 °F to +122 °F)	Natural white
PP	Glass fiber reinforced PP designed for demanding applications where a high level of chemical resistance is required.	1.13	+5 °C to +105 °C (+40 °F to +220 °F)	Natural white
CR	Extremely chemical resistant fluorinated thermoplastic material. Good strength, low friction and good abrasion resistance. Especially for applications with high demands for chemical or hot water resistance.	1.78	Dry conditions: +5 °C to +115 °C (+40 °F to +239 °F) Wet conditions: +5 °C to +115 °C (+40 °F to +239 °F)	White

Steel chains				
Material	Description	Density [g/cm ³]	Temperature range	Standard color
CS	Carbon steel – 43 HRC	7.85	Wet conditions: not recommended Dry conditions: -40 °C to +180 °C (-40 °F to +355 °F)	Black
SS	Inox for standard applications – Ferritic stainless steel, magnetic qualities, and good chemical resistance. Suitable for most applications and environments.	7.90	Dry conditions: -40 °C to +260 °C (-40 °F to +500 °F) Wet conditions: -40 °C to +120 °C (-40 °F to +248 °F)	Gray
SH	Hard Inox for high strength applications – Martensitic stainless steel, magnetic qualities, better mechanical resistance and less chemical resistance, Ra < 0.3	7.70	Dry conditions: -40 °C to +260 °C (-40 °F to + 500 °F) Wet conditions: -40 °C to +120 °C (-40 °F to +248 °F)	Gray
SA	18/8 SS with high chemical resistance – Austenitic stainless steel, non-magnetic, with better chemical resistance and wear resistance, but less mechanical strength. Used in tough environments or for esthetic reasons.	7.90	Dry conditions: -40 °C to +400 °C (-40 °F to +752 °F) Wet conditions: -40 °C to +120 °C (-40 °F to +248 °F)	Gray

Pins				
Material	Description	Density [g/cm ³]	Temperature range	Standard color
J	Case hardened carbon steel (steel chains only)	7.85	Wet conditions: not recommended Dry conditions: -40 °C to +180 °C (-40 °F to +355 °F)	Gray
K	Standard applications - Ferritic stainless steel, magnetic qualities, and good chemical resistance. Suitable for most applications and environments. Standard pin for plastic and steel chains. AISI 430 for plastic chains, and AISI 431 for steel chains (Previous code SS).	7.90	Dry conditions: -40 °C to +260 °C (-40 °F to +500 °F) Wet conditions: -40 °C to +120 °C (-40 °F to +248 °F)	Gray
P	High chemical resistance - Austenitic stainless steel, non-magnetic, with better chemical resistance and wear resistance, but less mechanical strength. Used in tough environments or for esthetic reasons. AISI 304 (Previous code SA)	7.90	Dry conditions: -40 °C to +400 °C (-40 °F to +752 °F) Wet conditions: -40 °C to +120 °C (-40 °F to +248 °F)	Gray
Q	High chemical resistance - Austenitic stainless steel, non-magnetic with increased resistance to chloride corrosion. AISI 316 (Previous code IN)	7.90	Dry conditions: -40 °C to +400 °C (-40 °F to +752 °F) Wet conditions: -40 °C to +120 °C (-40 °F to +248 °F)	Gray

Pins				
Material	Description	Density [g/cm ³]	Temperature range	Standard color
L	Wear and fatigue resistant highly reinforced Polyamide. Easy to recycle option for plastic chains. (Previous code PA)	1.55	Dry conditions: -40° C to +145 °C short-term +175 °C (-40°F to +293 °F short-term +347 °F) Wet conditions: not recommended	Natural beige
N	Extra low friction PBT material with good strength and very good abrasion resistance. Easy to recycle for selected plastic chains. (Previous code NG)	1.30	Dry conditions: -40 °C to +120 °C (-40 °F to +248 °F) Wet conditions: -40 °C to +50 °C (-40 °F to +122 °F)	Natural white

Sprockets				
Material	Description	Density [g/cm ³]	Temperature range	Standard color
GS	Reinforced polyamide with high strength and wear resistance for long life Multi-Hub sprockets.	1.37	Dry conditions: -46 °C to +118 °C (-50 °F to +245 °F) Wet conditions: -40 °C to +50 °C (-40 °F to +122 °F)	Black
ND	Tough, wear resistant and noise dampening material for Multi-Hub sprockets.	1.24	-20 °C to +50 °C (-4 °F to + 120 °F)	Dark gray
PE	Tough, wear resistant and noise dampening UHMWPE. Not suitable for abrasive applications. For machined sprockets.	0.94	-70 °C to +65 °C (-94 °F to +150 °F)	Natural white
NY	High heat resistant, good abrasion resistant polyamide sprocket material. For machined sprockets.	1.14	Dry conditions: -46 °C to +118 °C short-term +135 °C (-50 °F to +245 °F short-term +275 °F) Wet conditions: not recommended	Natural white
L	Extra low friction POM (Acetal) with self-lubricating agent for Multi-Hub idler and molded sprockets.	1.41	Dry conditions: -40 °C to +93 °C (-40 °F to +200 °F) Wet conditions: -40 °C to +60 °C (-40 °F to +140 °F)	Black
CI	Cast iron for solid sprockets. Suitable in non-corrosive, abrasive environments, such as glass conveying.	7.85	Dry conditions: -40 °C to +180 °C (-40 °F to +355 °F) Wet conditions: not recommended	Black

Introduction

Material overview

Accessories				
Material	Description	Density [g/cm ³]	Temperature range	Standard color
G	For GripTop inserts on Slat Top Plastic Chains	1.16	-40 °C to +60 °C (-40 °F to +140 °F)	Black or White
PL	For GripTop inserts on Slat Top Plastic and Snap-on Chains	1.14	-40 °C to +80 °C (-40 °F to +176 °F)	Black or White
HY	For GripTop inserts on Slat Top Plastic and Snap-on Chains	1.20	-40 °C to +110 °C (-40 °F to +230 °F)	Black or white
PP	Polypropylene glass fiber reinforced, for retainer rings	1.13	+5 °C to +105 °C (+40 °F to +220 °F)	Blue

Characteristics	Plastics																	
	DP	LF	PT	TS	NG	PK	EC	DE	NY	WR	HT	PP	CR	PA	GS	ND	PE	L
Impact resistance																•	•	
Wear resistance						•				•	•				•	•	•	
Chemical resistance												•					•	
Chemical resistance (high requirements)													•					
Low friction		•	•	•	•								•					•
Suitability in wet environments	•	•	•	•	•	•		•				•	•		•	•	•	•
Electrically conductive							•											
Direct food contact		•																
Magnetic																		
Noise dampening																•	•	

Characteristics	Plastics		
	G	PL	HY
Impact resistance	•	•	•
Wear resistance	•	•	•
Chemical resistance			
Chemical resistance (high requirements)			
Low friction			
Suitability in wet environments	•	•	•
Electrically conductive			
Direct food contact			
Magnetic			
Noise dampening	•	•	•

Steel					
CS	CI	SS	SH	SA	IN
•	•	•	•	•	•
•	•	•	•	•	•
		•	•		
				•	•
					•
		•	•	•	
•	•	•	•	•	•
		•	•	•	•
•	•		•		

A typical chain conveyor consists of the components shown below.

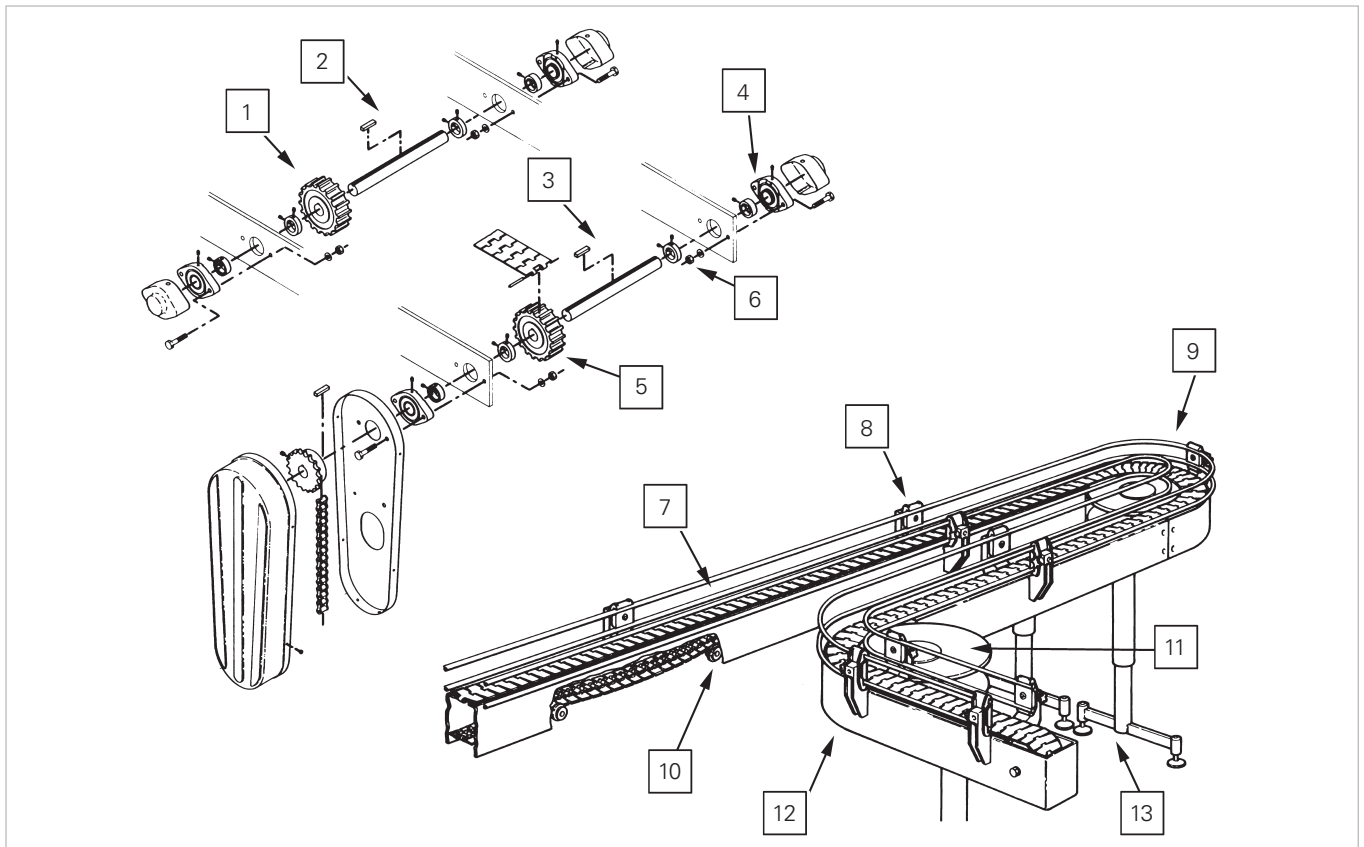

- 1 Idler
- 2 Idling shaft
- 3 Drive shaft
- 4 Flange bearing
- 5 Drive sprocket
- 6 Retainer ring
- 7 Wear strip
- 8 Rail
- 9 Curve
- 10 Return rollers
- 11 Disc wheel
- 12 Conveyor frame
- 13 Conveyor foot

Make sure the conveyor is leveled. Wear strips, rollers and chains will wear unevenly if the conveyor does not stand horizontal.

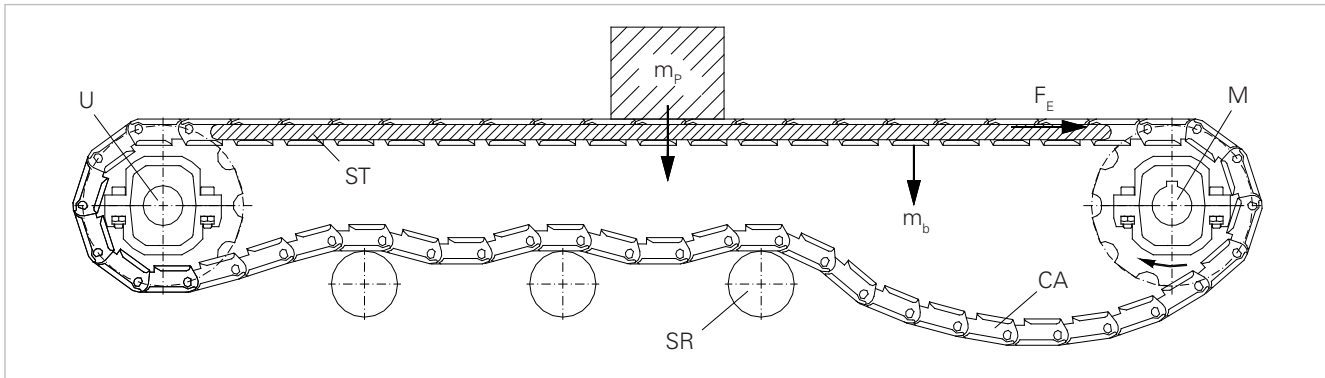

- M** **Driving shafts** for chain conveyors are usually round with keyway. For keyway dimensions see chapter "Design Guide – Shaft and keyway dimension".
- U** **Idling shafts** (round without keyway) can be equipped with sprockets or idlers.
- ST** **Wear strips on the transport side** carry the moving chain and load.
- SR** **Chain support on the return side** can be equipped with rollers or longitudinal wear strips (slider support).

- CA** **Catenary sag** is an unsupported length of the chain for absorbing chain length variations due to thermal expansion, load changes, chain wear and chain tension.
- F_E** **Effective tensile force (chain pull)** is calculated near the driving sprocket, where it reaches its maximum value during operation. It depends on the friction forces between chain and support (ST) (SR) as well as on friction against accumulated load.
- m_p** **Conveyed product mass (weight)** calculated in N (*lbf*).
- m_b** **Chain mass (weight)** is added to the product mass for calculation of the friction force between chain and support.

Straight-running configuration

A straight conveyor with a single idle end [A] and drive end [B] that is pulling the chain is the simplest design. If the distance traveled is longer than one conveyor can pull, several conveyors with transfers may be required. See section on transfers.

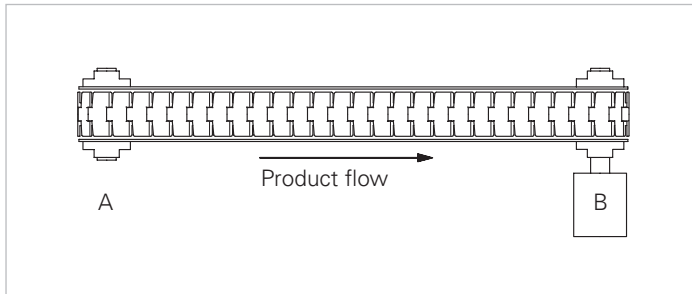

Radius configuration

A conveying system may not always use straight conveyors due to the process flow or obstructions, a radius conveyor can be utilized.

Location of the curve section in relation to the drive end [B] is critical to keep tensions lower. To reduce the tension in the system, the curve section should be located as close as possible to the idle end [A] of the conveyor. The ideal diagram below shows the curve section close to the idle end which minimizes the tension increase through the curve.

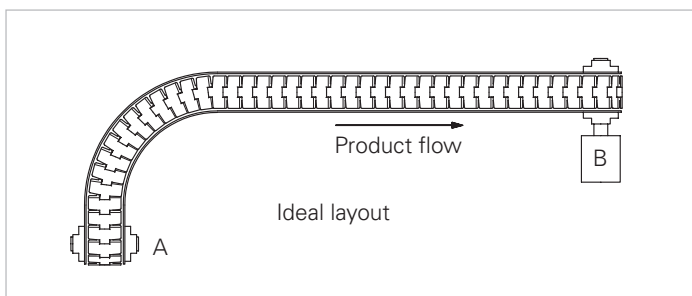

The non ideal diagram below shows the curve close to the drive end [B]. This layout will significantly increase the tension in the system and should be avoided if possible.

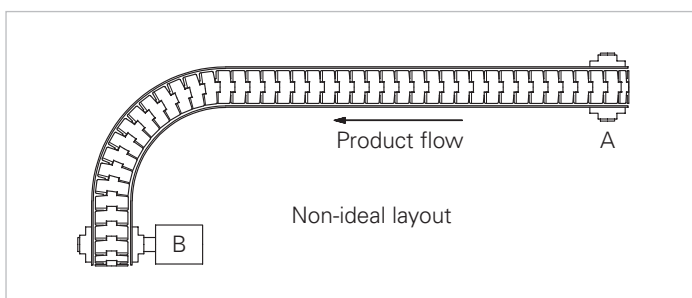

The number of curves and the angle of each curve should be minimized in each conveyor section to keep the tension in the system within limits. The HabaCHAIN® SeleCalc is a tool that can be used to calculate the tensions.

Conveyor length

Maximum length of conveyors

Several factors influencing conveyor length:

- Conveyor configuration
- Chain type
- Coefficient of friction
- Load
- Speed

In normal practice track lengths should not exceed 20 m (*66 ft*) center to center.

It is important to consider that wear is dependent on the environment, the load, the speed and the run time. Due to the limited stiffness of plastic chains compared to steel chains the chance of pulsation increases with the conveyor length. Please contact Habasit for more information.

Radius conveyors

Distance between curves

A minimum straight section of 100 mm is recommended between turns in opposite directions. There is no minimum straight length between curves in the same direction.

Distance to sprocket or idler

At both the drive and sprocket ends, near the drive or idling shafts, a minimum straight length of 100 mm plus sprocket radius is required.

Elevating conveyors

Recommended maximum conveyor elevation angle

3° to 5° is considered as maximum angle for Slat Top plastic chains. Depending on chain type, product to convey and environment the higher values can be achieved. Contamination of the chain influences the coefficient of friction between chain and product. For higher inclination angles the use of molded rubber inserts (GripTop) or flights is necessary to avoid unwanted sliding of conveyed products. Accumulation cannot occur if GripTop inserts are installed in the chain.

With angles of incline greater than 7°, the catenary sag will move from the drive or elevated section, to the idle section. A catenary pocket can be used but if the catenary will interfere with conveyor structure, a take-up may be required.

Note: Inserts must not contact wear strips. Please see the HabaCHAIN® Product Guide for detailed information on flights and molded rubber inserts.

Design recommendations:

- Soft start/stop for drive in inclined and declined sections
- Dynamic tensioner
- Drive at the upper end of the conveyor

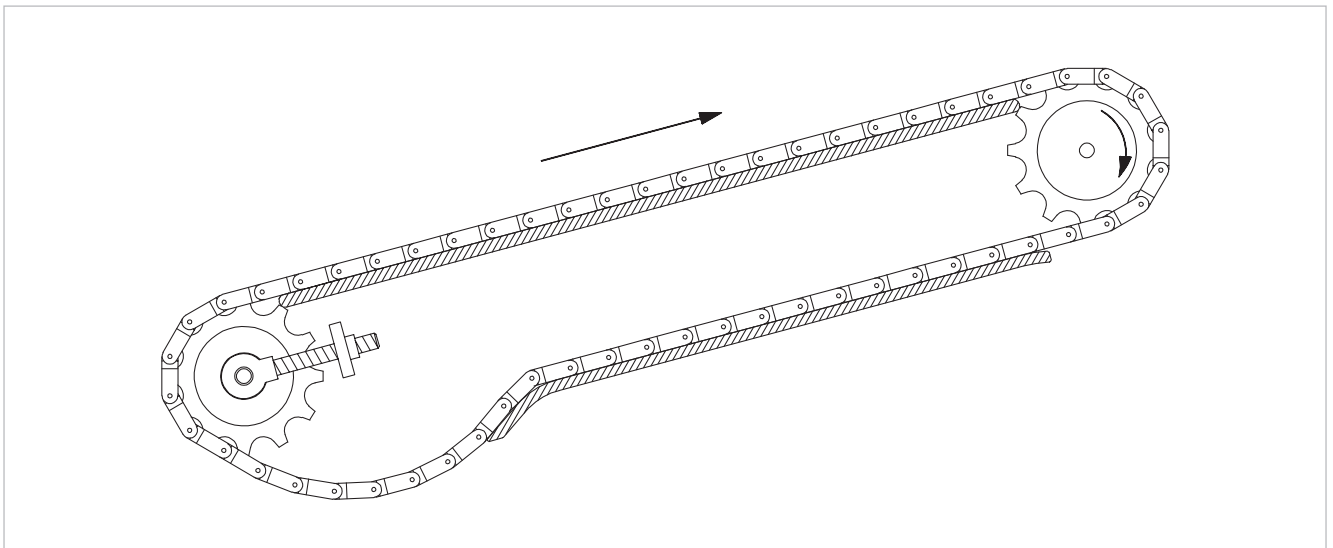

Transfers

There are many methods to smoothly transfer product from one conveyor to another. Choosing the method that best suits the product that is being conveyed is essential for continuous flow of product.

Side transfer or parallel transfer unit

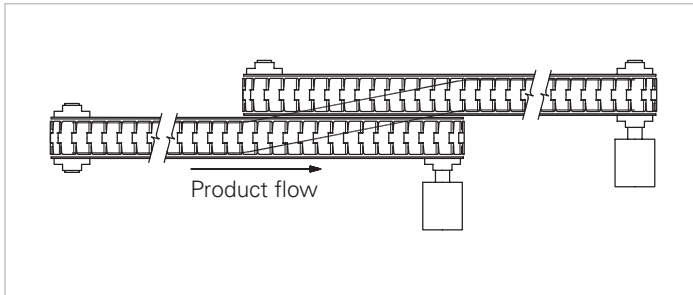

- A side transfer is comprised of two conveyors in parallel. In most cases, the idle end of the second conveyor is along side the drive end of the first conveyor
- Guide rails guide the product across the chains to complete the transfer
- Select chains that are the **same thickness** so that the internal wear strips can be common
- This is a self clearing transfer

Chart showing products with same thickness for transfers:

Thickness		Thickness		Thickness		Thickness	
3 mm		4 mm		4.8 mm		8.7 mm	
Straight	Radius	Straight	Radius	Straight	Radius	Straight	Radius
C0800	C0881	C0828	C0770	C0831	C0879	M2420	C1061
C0810		C0820	C0880	C0821	C0882	M2470	C1071
			C0890				

Inline transfer

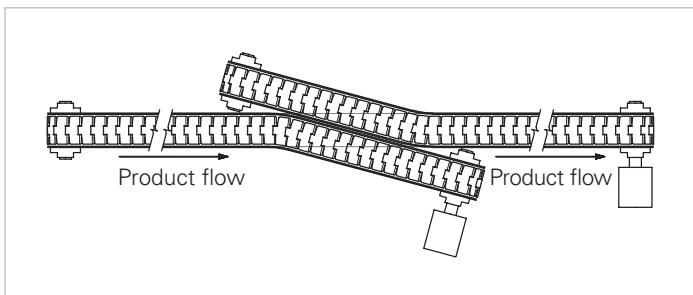

- Similar to the side transfer except the guide rails are straight and the conveyor has a slight turn to allow the transfer. This layout is more gentle on product but requires a radius chain.
- Select radius chains that are the **same thickness** so that the internal wear strips can be common
- This is a self clearing transfer

Over the end with transfer plates

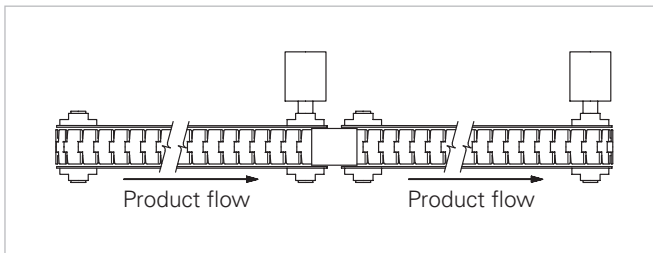

- The idle end of the second conveyor is directly ahead of the drive end of the first conveyor
- To fill the gap, a transfer plate is used. This plate could be manufactured from steel, UHMW, or rollers
- The transfer plate coming off the drive should be slightly lower to eliminate trip point; same with the idle end coming from the transfer plate
- This is not a self clearing transfer
- **Caution as there is a potential pinch point**

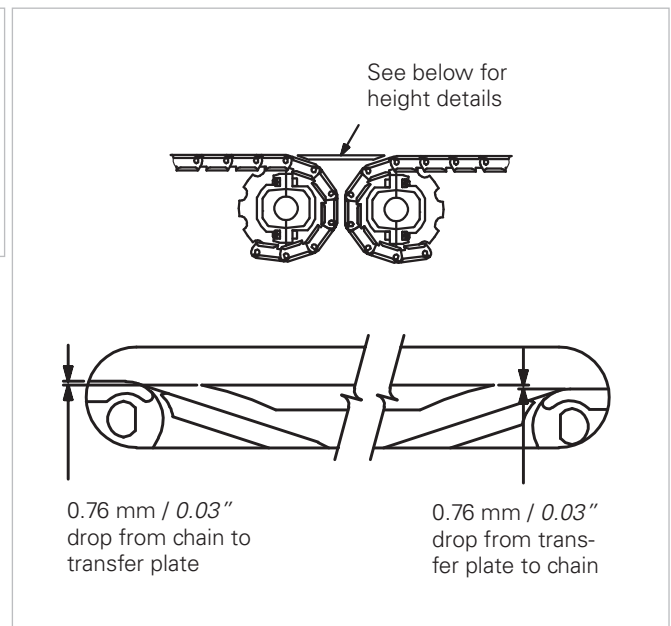

90° with transfer plate

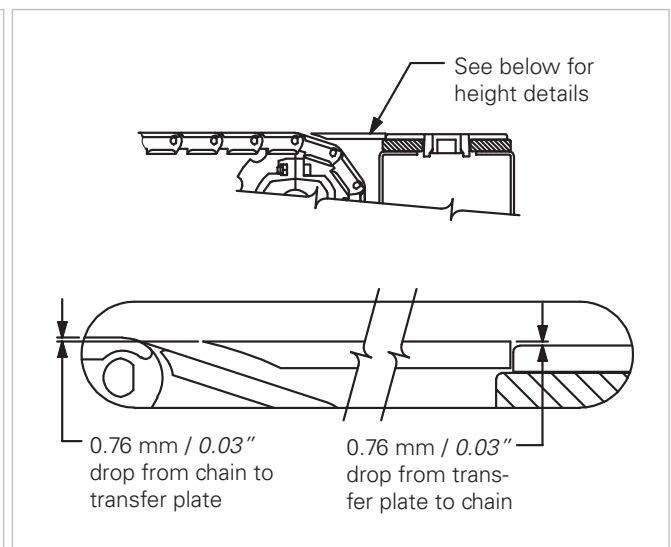
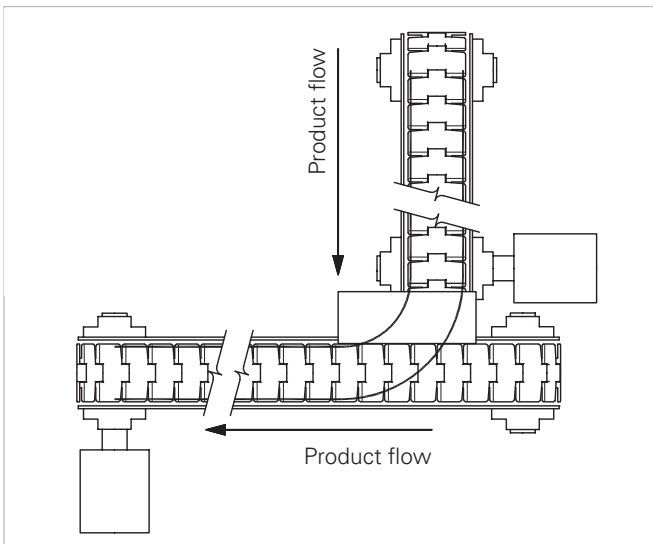

- Similar to over the end transfer except the conveyors are at 90° to each other
- To fill the gap, a transfer plate is used. This plate could be manufactured from steel, UHMW, or rollers
- The transfer plate coming off the drive should be slightly lower to eliminate trip point; same with the conveyor coming from the transfer plate
- This is not a self clearing transfer
- **Caution as there is a potential pinch point**

Combiners

- Combiners take product that is slow moving and in mass to a faster moving single file conveyor
- Product will transfer across a series of chains that become narrower and faster moving until the product is in single file
- Select chains that are the **same thickness** so that the internal wear strips can be common

Decombiner

- Decombiner takes product that is fast moving in single file to slow moving mass conveyor
- Product will transfer across a series of chains that become wider and slower moving until the product is in mass
- Select chains that are the **same thickness** so that the internal wear strips can be common

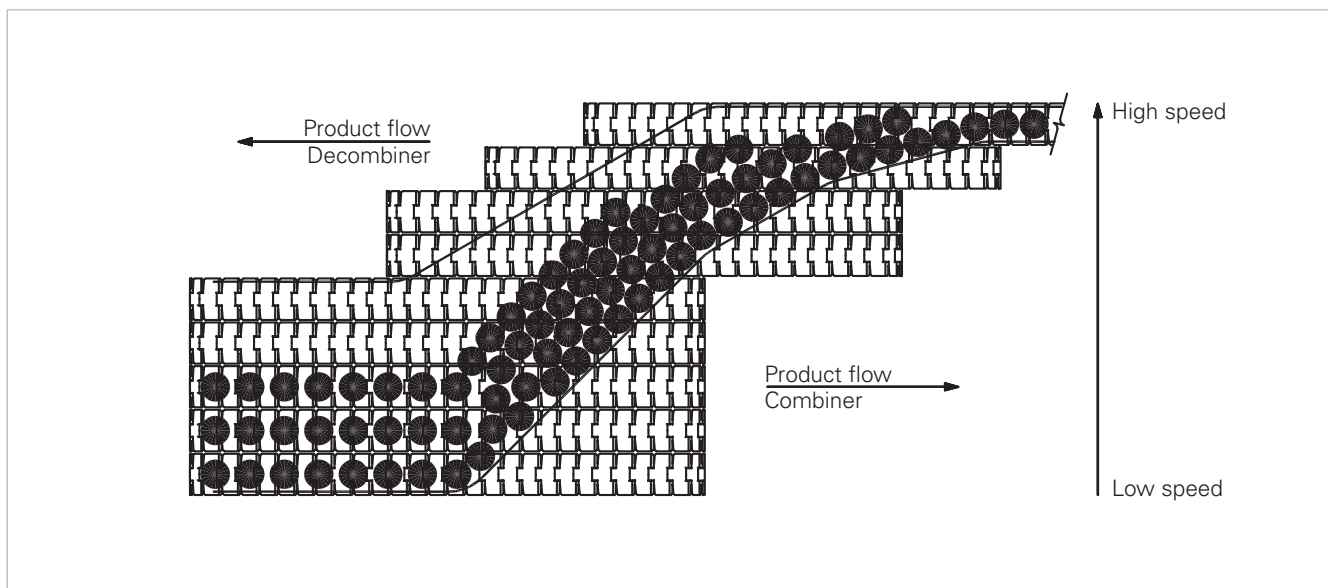

Product shown on combiner

For both combiners and decominers keep the speed differential between adjacent lanes between 15 and 23 m/min (50 – 75 ft/min). This is to avoid containers falling when moving across chains at different speeds.

Specialty conveyors

Alpine conveyors

- A single strand chain conveyor that inclines or declines between 180° wheel turns
- Used to elevate or lower product in a small area or used as an in-line accumulation conveyor
- Multi-flex chains, C1700, C1701T and C1702 are typically used
- Length of straights between wheel turns depends on the angle of incline/decline and height of product. Enough straight is required to allow the next level (– tier pitch –) to clear the product
- Angle of incline is dependent on the product and friction. Too great of an angle will cause the product to slip. Too little of an incline will require longer centers to achieve the required tier pitch

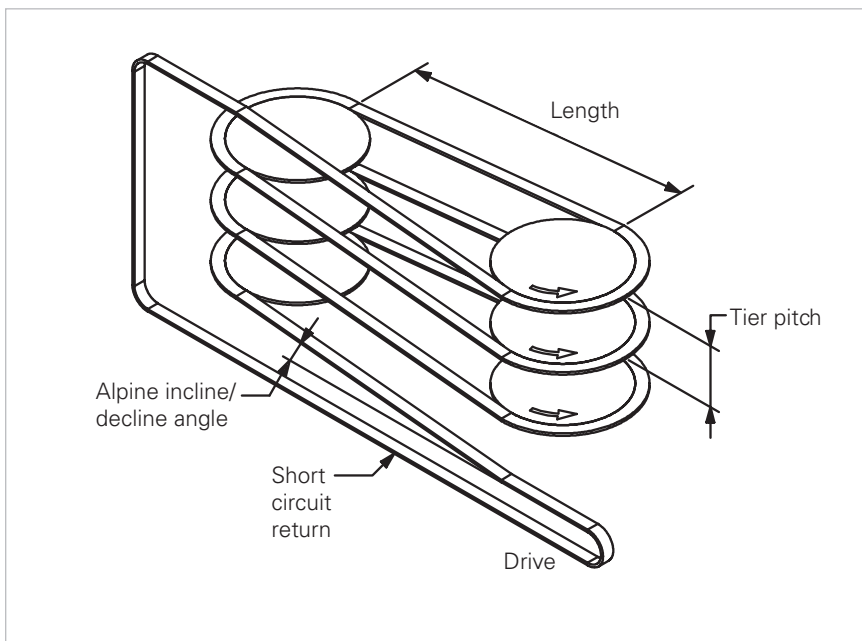

Gripper conveyors

- Side grip conveyors utilize two strands of chain that squeeze or grip the product between the two strands
- The product is held by its side versus a conventional conveyor that carries the product from underneath

Gripper chains are designed to carry a product in between strands as shown below.

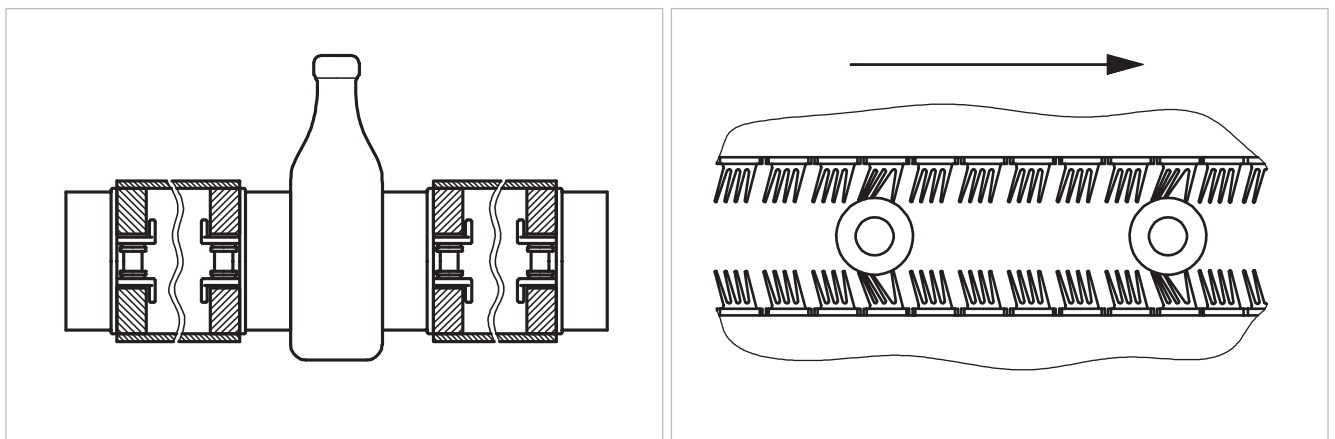

Gripper conveyors are used in many applications:

- Elevate a product from lower elevation to a higher elevation “S” shape
- Lower a product from a higher elevation to a lower elevation “S” shape
- Invert a product “C” shape
- Grip product invert and rinse and invert again to continue on the conveyor
- Sterilize the cap of a product by inverting after the container has been filled

Various gripper conveyor configurations are possible:

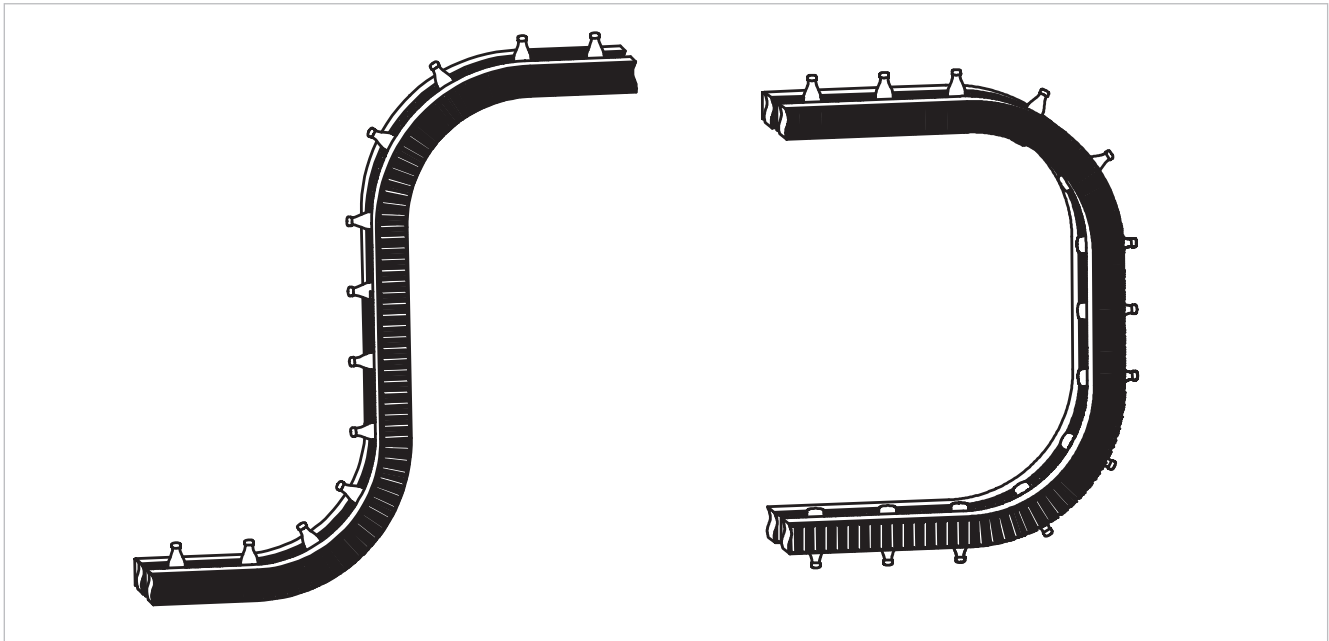

“S” shape: transfers a product from one level to another without changing its orientation

“C” shape: used when the product needs to be turned from one side to another over two levels

“U” shape: designed as an upside down “U”; this design allows for passage underneath the conveyor

Important considerations for designing a gripper conveyor:

- Chain is on its side not allowing a catenary, a tensioner will be required on the idle end of the system
- Gripper conveyor speed must be greater than the infeed to allow a gap between the products to keep the product from interfering with each other when going through a curve section
- Install a sufficient radius on the gripper chain to allow the product to transition from horizontal to vertical incline (if not a 90 degree elevator)
- Design the conveyor in a way to adjust the distance between the gripper chains
- Choose the appropriate gripper for the product:
 - Heavy, rigid, non round product use a “d” style gripper
 - Light, flexible, round product use the four-finger gripper

Sprocket and idler positioning

To have proper engagement between the sprocket and chain, the location of the end of the wear strip to the center of the shaft is critical. These dimensions are called out as A₁ and C dimensions below. Please refer to the charts below as appropriate.

For HabaCHAIN® Multi-Hub sprockets

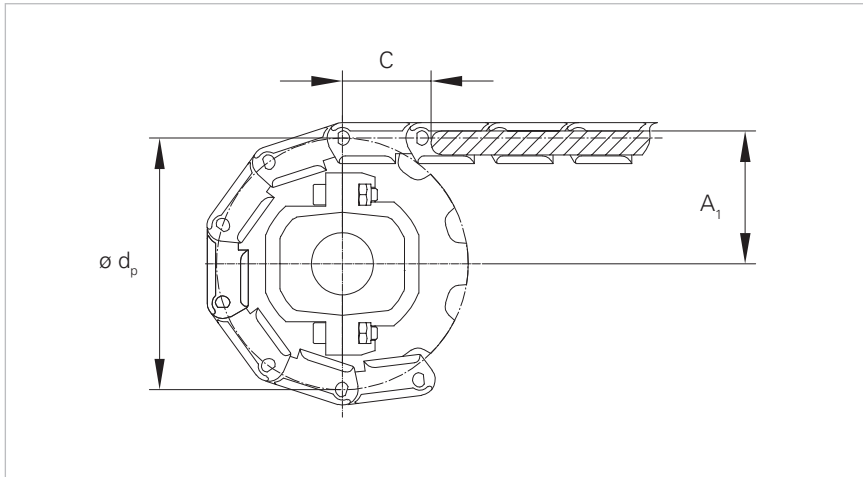

Chain type	Multi-Hub sprocket	Number of teeth	Diam. of pitch d _p		A ₁		C	
			mm	inch	0/+2 mm	0/+0.08"	0/+2 mm	0/+0.08"
770T	C1060G16-	16	130.2	5.13	67.5	2.65	25.4	1.00
	C1060G18-	18	146.3	5.76	75.5	2.97	25.4	1.00
820	C0820G21-	21	129.3	5.09	67.9	2.67	38.1	1.50
	C0820G23-	23	141.2	5.56	73.8	2.91	38.1	1.50
	C0820G25-	25	153.2	6.03	79.8	3.14	38.1	1.50
821 series	C0821G25-	25	153.2	6.03	79.7	3.14	38.1	1.50
831	C0820G21-	21	129.3	5.09	67.1	2.64	38.1	1.50
	C0820G23-	23	141.2	5.56	73.0	2.87	38.1	1.50
	C0820G25-	25	153.2	6.03	79.0	3.11	38.1	1.50
879 series	C0880G10-	10	123.3	4.85	64.5	2.54	38.1	1.50
	C0880G12-	12	147.2	5.80	76.4	3.01	38.1	1.50
880 series, 890T	C0880G10-	10	123.3	4.85	65.3	2.57	38.1	1.50
	C0880G12-	12	147.2	5.80	77.2	3.04	38.1	1.50
881 series	C0881G25-	25	153.2	6.03	80.1	3.15	38.1	1.50
882 series	C0882G12-	12	147.2	5.80	78.3	3.09	38.1	1.50
1061M, 1071B	C1060G16-	16	130.2	5.13	68.4	2.69	25.4	1.00
	C1060G18-	18	146.3	5.76	76.5	3.01	25.4	1.00
1061T	C1060G16-	16	130.2	5.13	67.6	2.66	25.4	1.00
	C1060G18-	18	146.3	5.76	75.6	2.98	25.4	1.00

For HabaCHAIN® solid sprockets

For solid sprockets, depending if the chain pitch is above or below the wear strip, formulas are used to calculate the location of the shaft with respect to the end of the wear strip. Dimension A1 is from the center of the shaft to the top of the wear strip.

The tables have the corresponding constants E and F for the chain types that are used in the A1 formula.

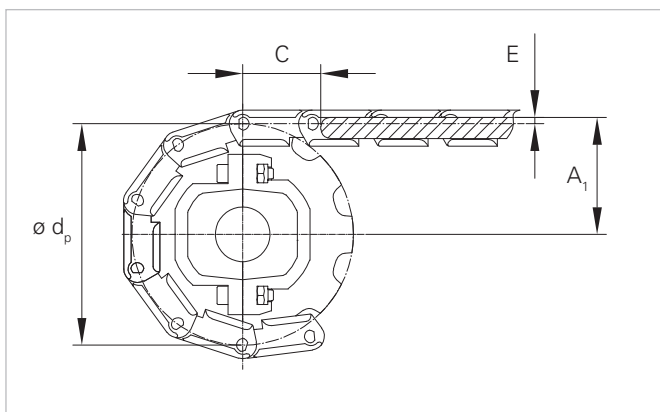

$$A1 = \varnothing d_p / 2 + E \quad [\text{mm}], [\text{inch}]$$

Please use the below indicated values for E according to the chain type.

Chain type	Solid sprocket	E		C	
		mm	inch	mm	inch
770T	C1061Z-	2.5	0.10	25.4	1.0
800	C0821M-	3.5	0.14	38.1	1.5
810	C0810M-	3.5	0.14	38.1	1.5
820	C0820M-	3.2	0.13	38.1	1.5
821	C0821M-	3.1	0.12	38.1	1.5
831	C0820M-	2.4	0.09	38.1	1.5
843 series	#40, 08-B	5.8	0.23	25.4	1.0
863 series	#60, 12-B	10.3	0.41	38.1	1.5
879 series	C0880M-	2.8	0.11	38.1	1.5
880 series, 828	C0880M-	3.6	0.14	38.1	1.5
881 series	C0881M-	3.5	0.14	38.1	1.5
882 series	C0882M-	4.7	0.19	38.1	1.5
890T	C0880M-	3.6	0.14	38.1	1.5
963 series	#60, 12-B	10.3	0.41	38.1	1.5
1061T	C1061Z-	2.5	0.10	25.4	1.0
1061M, 1071B	C1061Z-	3.3	0.13	25.4	1.0
1843T	#40, 08-B	6.0	0.24	25.4	1.0
1873 series, 3873	#60, 12-B	10.3	0.41	38.1	1.5
1874T	#60, 12-B	11.3	0.44	38.1	1.5
7100K0248	C7100M16-R2	10.0	0.39	25.4	1.0
7100K0325	C7100M12-R3	12.5	0.49	33.5	1.3
7100K0405	C7100M12-R4	12.2	0.48	35.5	1.4

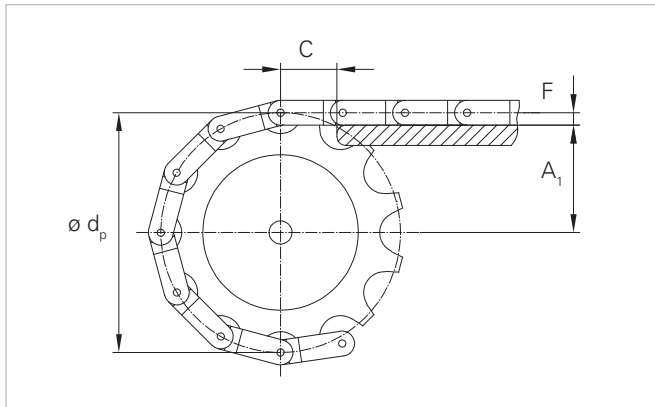

$$A1 = \varnothing d_p / 2 - F \quad [\text{mm}], [\text{inch}]$$

Please use the below indicated values for F according to the chain type.

Chain type	Solid sprocket	F		C	
		mm	inch	mm	inch
600 series	C0600M-	14.2	0.56	63.5	2.5
1100, 1110T	C1100M-	5.7	0.22	25.4	1.0
1150, 1151T	C1150M-	8.7	0.34	38.1	1.5
1200, 1210T, 3200, 3210T	C1200M- C3200M-	10.1	0.40	50.8	2.0
1250, 1251T	C1250M-	15.9	0.63	63.5	2.5
1400, 1410T	C1400M-	19.1	0.75	82.6	3.25
1700, 1701T, 1702	C1700M-	12.1	0.48	50.0	1.97
NH78	CNH78M-	14.3	0.56	66.3	2.61
40P	#40, 08-B	6.2	0.24	12.7	0.50
60P	#60, 12-B	8.6	0.34	19.1	0.75

For HabaCHAIN® idler wheel equivalent positioning

The location of the idler wheel equivalent shaft with respect to the end of the wear strip is critical to have smooth transition from the idler wheel to the wear strip. Dimensions A₁ and C are dependent on chain type and idler wheel equivalent tooth count. The following charts show the A₁ and C dimensions.

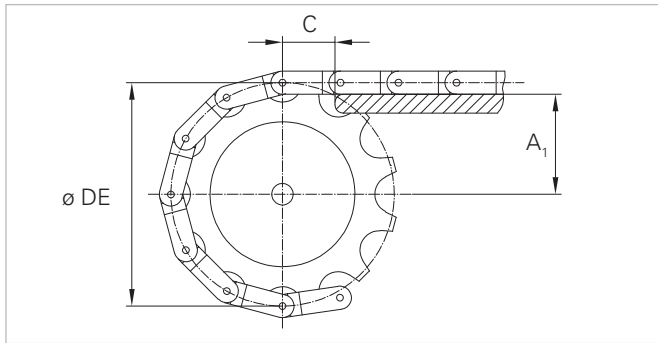

HabaCHAIN® Multi-Hub idlers

Chain type	Multi-Hub idler	Equivalent number of teeth	Diameter DE		A ₁		C	
			mm	inch	0/+2 mm	0/+0.08"	0/+2 mm	0/+0.08"
810, 820, 828, 831, 879B, 880B, 880J, 880LJ, 880M, 881B, 1061M	C0820L21-	21	130.0	5.12	68.0	2.68	38.1	1.50
	C0820L23-	23	142.5	5.61	74.0	2.91	38.1	1.50
	C0820L25-	25	154.5	6.08	80.0	3.15	38.1	1.50

HabaCHAIN® solid idlers

Chain type	Solid idler	Equivalent number of teeth	Diameter DE		A ₁		C	
			mm	inch	0/+2 mm	0/+0.08"	0/+2 mm	0/+0.08"
810, 820, 828, 831, 879B, 880B, 880J, 880LJ, 880M, 881B, 1061M	C0810L17-	17	105.0	4.13	55.5	2.19	38.1	1.50
	C0810L19-	19	117.1	4.61	61.5	2.42	38.1	1.50
	C0810L27-	27	166.6	6.56	86.5	3.41	38.1	1.50
7100K0248	C7100L16...R2	16	119.5	4.70	74.7	2.94	25.4	1.00
7100K0325	C7100L12...R3	12	117.8	4.64	76.9	3.03	33.5	1.32
7100K0405	C7100L12...R4	12	123.0	4.84	80.7	3.18	35.5	1.40

Shaft and keyway dimension

For HabaCHAIN® Multi-Hub sprockets and idlers we recommend the following shaft and keyway dimensions.

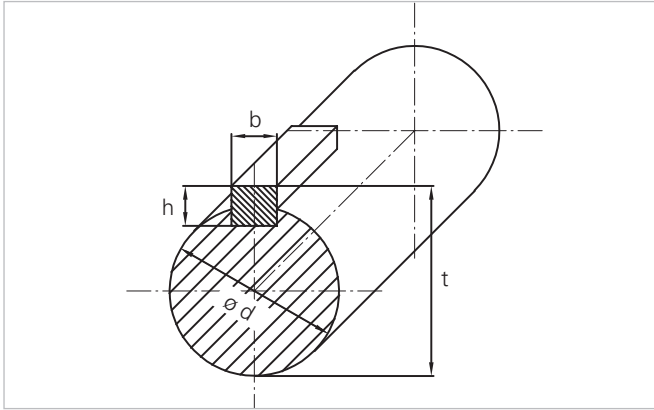

For metric shafts

Hub type		Nominal size [mm]	Tolerance [mm]		Tolerance class
			+	-	
H025RZ	d	25	0	0.052	h9
	t	28	0	0.350	
	b	8	0	0.036	h9
	h	7	0	0.090	h11
H030RZ	d	30	0	0.052	h9
	t	33	0	0.350	
	b	8	0	0.036	h9
	h	7	0	0.090	h11
H035RZ	d	35	0	0.062	h9
	t	38	0	0.350	
	b	10	0	0.036	h9
H040RZ	d	40	0	0.062	h9
	t	43	0	0.350	
	b	12	0	0.043	h9
H025RL	d	25	0	0.052	h9
	t	28	0	0.350	
	b	8	0	0.036	h9
	h	7	0	0.090	h11
H030RL	d	30	0	0.052	h9
H035RL	d	35	0	0.062	h9
H040RL	d	40	0	0.062	h9

For imperial shafts

Hub type	Nominal size [inch]	Actual size [inch]	
		t	b
H100RZ	1	t	1.111
		b	0.250
		h	0.250
H118RZ	1 3/16	t	1.299
		b	0.250
		h	0.250
H125RZ	1 1/4	t	1.361
		b	0.250
		h	0.250
H144RZ	1 7/16	t	1.605
		b	0.375
		h	0.375
H150RZ	1 1/2	t	1.667
		b	0.375
		h	0.375
H100RL	1	d	1.000
H118RL	1 3/16	d	1.188
H125RL	1 1/4	d	1.250
H144RL	1 7/16	d	1.438
H150RL	1 1/2	d	1.500

Roller chain sprockets

Roller chain sprockets are used for all snap-on chains and two case chains (C0040, C0060)

- Standard ANSI roller chain sprockets are used for several Habasit chains. Follow the chart for sprocket selection
- The snap-on chains with tabs may interfere with the hub of a standard roller chain sprocket. Follow the chart to ensure a sprocket is selected with a hub diameter that will not interfere with the tab. Please note that the hub size and dimensions are not defined by a specific standard. Each manufacturer could design these items in a very specific way. For this reason, in the chart the values for the minimum sprocket size are representative of what is commonly available on the market and each indication is linked to a specific hub size. If you are going to use hub sizes larger than what we indicate in this chart, we cannot guarantee the compatibility. Please contact your Habasit representative to define proper sprocket sizes.
- If snap-on chains wrap around a sprocket that is too small, the top plates can interfere. The table below indicates the minimal sprocket diameter for each chain type

Minimum sprocket diameter for snap-on chains

Chain series	Chain pitch	Minimum sprocket	Type
	inch	Teeth	
843	1/2	13 (Hub Ø = 1.563")	ANSI #40
843C	1/2	13 (Hub Ø = 1.563")	
40P	1/2	13 (Hub Ø = 1.563")	
1843T	1/2	24 (Hub Ø = 3.0")	
863	3/4	13 (Hub Ø = 2.345")	ANSI #60
60P	3/4	13 (Hub Ø = 2.345")	
863T	3/4	22 (Hub Ø = 4.0")	
1873T-T	3/4	22 (Hub Ø = 4.0")	
1873T	3/4	22 (Hub Ø = 4.0")	
963T	3/4	22 (Hub Ø = 4.0")	
1873-D1	3/4	22 (Hub Ø = 4.0")	
3873T	3/4	22 (Hub Ø = 4.0")	
1873-L4	3/4	22 (Hub Ø = 4.0")	
963	3/4	13 (Hub Ø = 2.345")	
1874T	3/4	22 (Hub Ø = 4.0")	

The polygon effect (chordal action)

Chain links moving around the radius of the sprocket causes the linear chain speed to vary. The pivot rod travels on the pitch diameter of the sprocket while the chain moves through the smaller chordal radius causing a horizontal rise and fall of the chain. This polygon effect is typical to all chain systems. The magnitude of speed variation is dependent on the number of sprocket teeth.

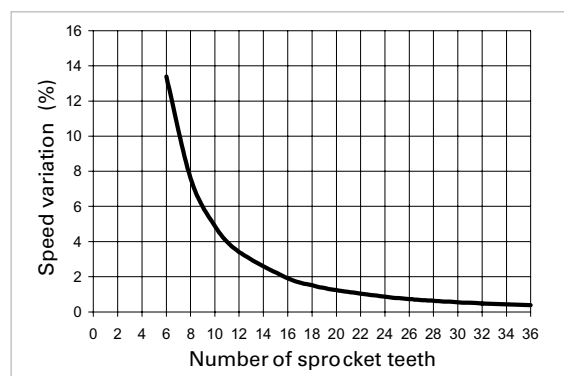

Drive and tensioning construction

Standard end drive

The motor is normally at the discharge of the conveyor. This drive system is unidirectional in which the chain is always pulled towards the discharge. A catenary sag is used to tension the chain. Please see sections below on catenary sag and return way entry for proper design details.

Catenary sag

Catenary sag is an unsupported length of chain for absorbing changes in chain length caused by thermal expansion, thermal contraction, load changes, and wear of the chain. Catenary sag is measured when the conveyor is running. If the catenary sag is greater than the recommendations, chain needs to be removed and catenary sag corrected. The catenary sag needs to be as close as possible to the drive. See diagram for proper dimensions.

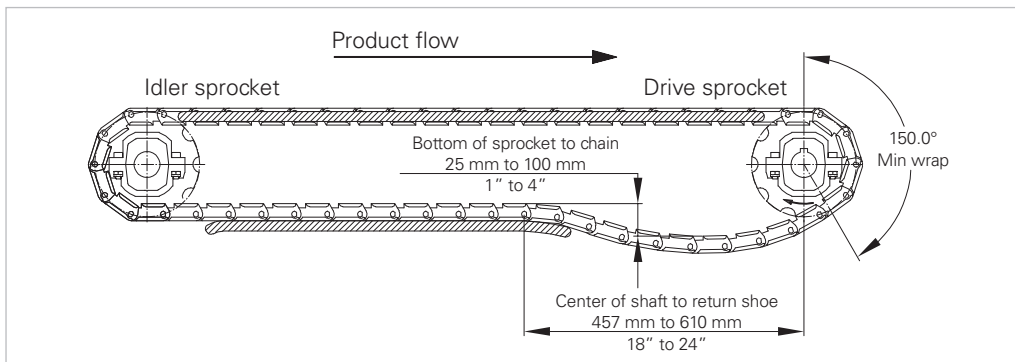

The catenary sag area needs to be free of obstruction including cross members, drive components, supports, and fasteners that can damage the chain. It is not recommended to run the chain tight and in most cases, take-ups are not typically used. For heavily loaded conveyors, a gravity tensioning device may be required to keep proper tension on chain.

Return way entry radius

For smooth transition of the chain from the catenary sag to the return, a return shoe is required with a radius of $1 - 1\frac{1}{2}$ times the back flex radius (see back flex chart on page 32).

For a tab return system, the return shoe needs to have a tangent of 3 times the pitch of the chain prior to the start of the wear strips that will hold the tabs. This will ensure the chain is flat and the tabs are in the same location for ease of entry in to the return wear strips.

The wear strips need to be chamfered so the chain has additional clearance when entering the return wear strips to prevent catching of the chain. The width between the two return wear strips must follow the guide clearance recommendations for the chain that is used.

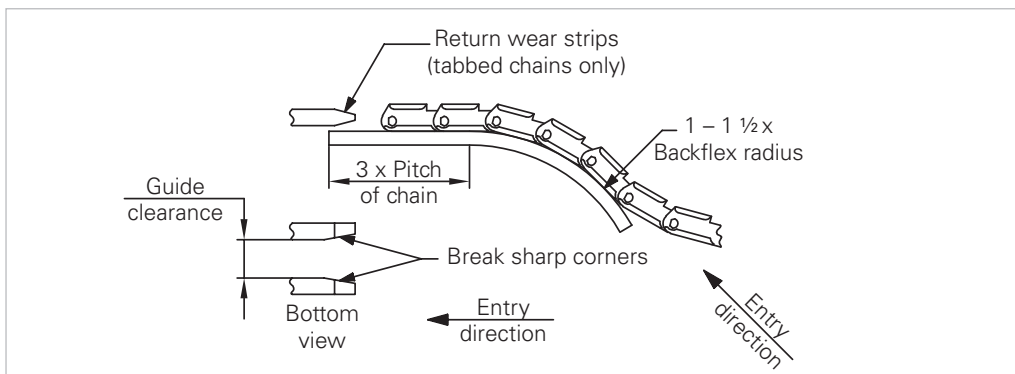

Minimum back flex radius chart

Chain type	Back flex radius R_b	
	mm	<i>inch</i>
770T 1061 1071B	130	5.12
820 821 831 879 880 882T 890	40	1.57
882B 1700 1701 600 601 610T 611T 1150 1151T 1400 1410T NH78	76	3.0
828	50	1.97
821 LBP	400	15.75
882 LBP	320	12.6
C7100K0248	70	2.76
C7100K0325	90	3.54
C7100K0405	100	3.94

Chain type	Back flex radius R_b	
	mm	<i>inch</i>
881 843 1200 1201 1210T 1211T 3200 3210	102	4.0
1843T	152	6.0
1874T 40P	200	7.87
60P	203	8.0
1100 1110T	51	2.0
1250 1251T	127	5.0
800 810 863 863T 963 1873TT 1873T 3873T	150	5.9

Center drive

The motor is located on the return side as close to center as possible. This drive system can be unidirectional or bi-directional. A catenary sag is used to tension the chain. In this case, the catenary sag is between the support rollers. Please note the diameter of the support rollers needs to be two times the back flex radius of the chain. The catenary sag will switch locations depending on the direction the chain is traveling. This is noted in the drawing below.

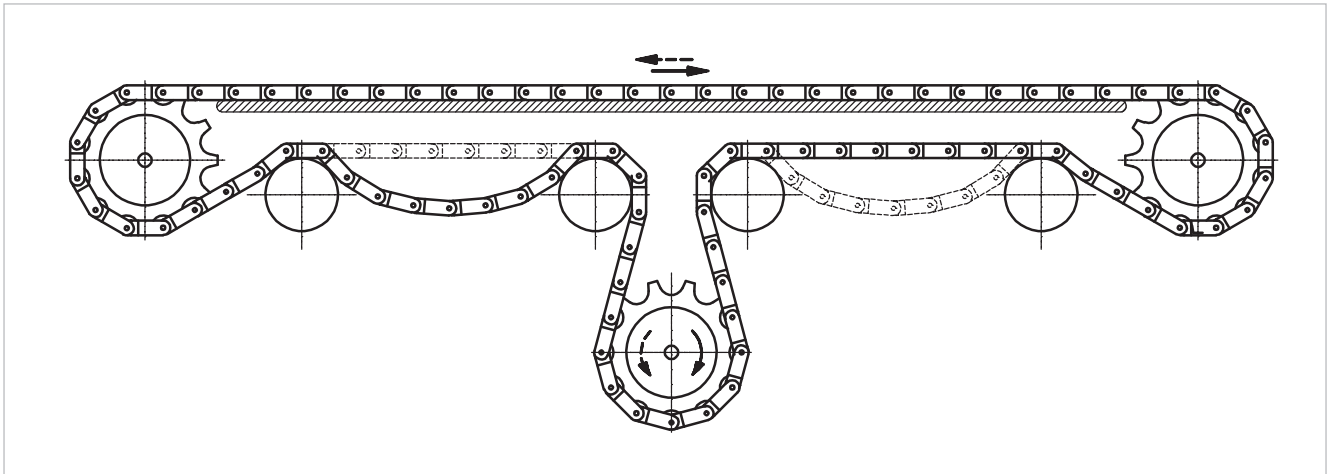

This drive system is not valid for all chain types and is **not recommended for long conveyors or conveyors with a curve.**

Offset Drive

Similar to standard end drive except the chain is guided (offset), through the catenary to the idle sprocket. This is a unidirectional drive.

Most of the return chain is eliminated, less chain in the system. The chain must be a side flexing type.

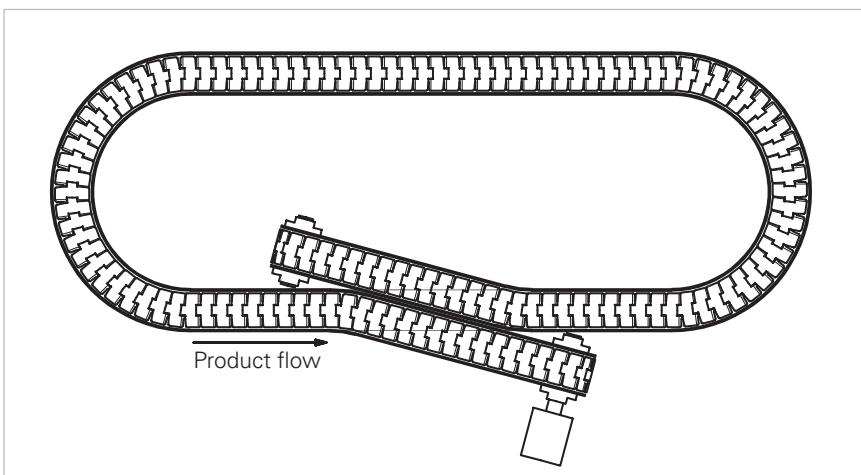

Transport side

The following are examples of typical carry ways for the transportation side for both straight and radius chains. Guide clearance, indicated in the chain drawing, is critical for proper guiding of the chain. The two charts below indicate the guide clearance for each series of chain. For radius chains, this dimension is different for straight and radius carry ways.

Straight running chains

Chain type	Guide clearance (J) Straight sections	
	mm	<i>inch</i>
820 828 831 810 1150	44.5	1.75
821 LBP 821 LBP821 SB	139	5.47
800	82.5	3.25
843 843C	23.9	0.94
863 963	36.5	1.44
863T 963T 1873T-T	33.3	1.31
40P	23	0.91
60P	33	1.3
1100	27	1.06
1200 1201AB 3200	59	2.32
1250	60.3	2.37
NH78	78	3.07

Side flexing chains

Chain type	Guide clearance (J) Straight sections		Guide clearance (J) Radius sections	
	mm	<i>inch</i>	mm	<i>inch</i>
770T 890 881T	46.0	1.81	44.5	1.75
879B 880B 880J 881B	44.5	1.75	41.3	1.62
879T 880T 880M 1061T 1061M	45.0	1.77	45.0	1.77
880LJ	43.0	1.69	40.5	1.59
882B	62.0	2.44	58.0	2.28
882T 882TG LBP 882T LBP 882T SB	58.0	2.28	58.0	2.28
1843T	22.4	0.88	21.3	0.84
1873T 1873-D1 1873-L4 3873	33.3	1.31	35.1	1.38
1874T	34.1	1.34	34.6	1.36
1700	58.0	2.28	58.0	2.28
1701T	69.0	2.71	57.2	2.25
1702	56.2	2.21	56.2	2.21
600 601	43.5	1.71	43.5	1.71
610T 611T 611TE 1151T	56.5	2.22	44.5	1.75
1110T	34.0	1.34	27.0	1.06
1210 1211TB 3210T	72.5	2.85	59.0	2.32
1251T	72.5	2.85	60.3	2.37
1400	54.0	2.13	54.0	2.13
1410T	72.5	2.85	54.0	2.13

Chain series:

- Straight running Slat top chains (C0820, C0831, C0821, C0828)
- Straight running steel chains (C0800, C0810)
- Straight running LPB chains (LBP821)
- Straight running Snap on (C0843, C0863, C0963)

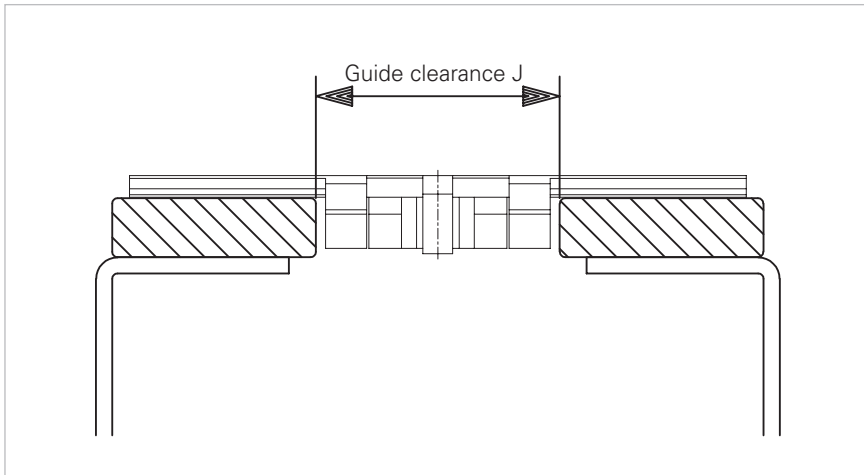

Chain series:

- Radius running slat top chain, beveled (C0879, C0880, C0880J, C0882)
- Radius running steel chains, beveled (C0881)

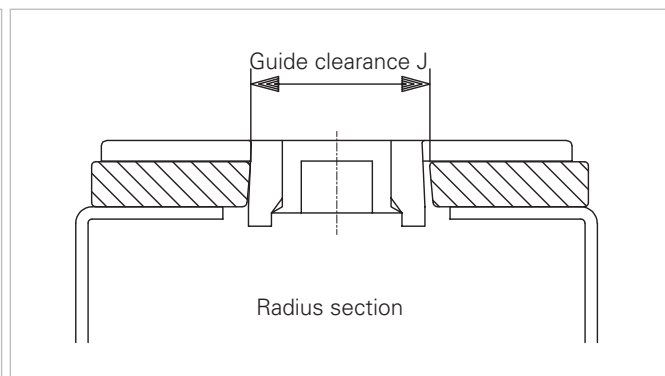
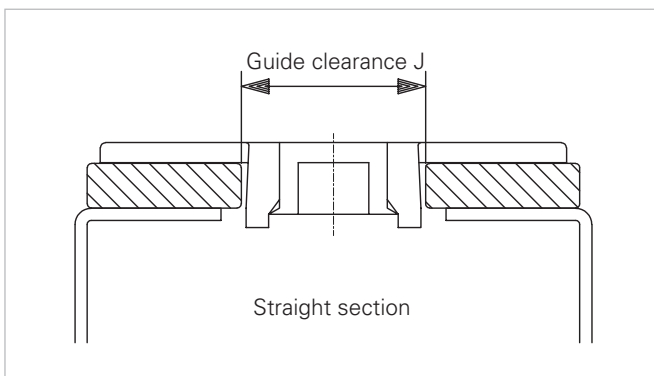

Chain series:

- Radius running slat top chain, tabbed (C0879, C0880, C0880J, C0882, C0770, C0890, C1061)
- Radius running steel chains, tabbed (C0881)
- Radius running LPB chains, tabbed (LBP882)
- Radius running Snap on, tabbed (C1843, C1873, C1874, C3873)

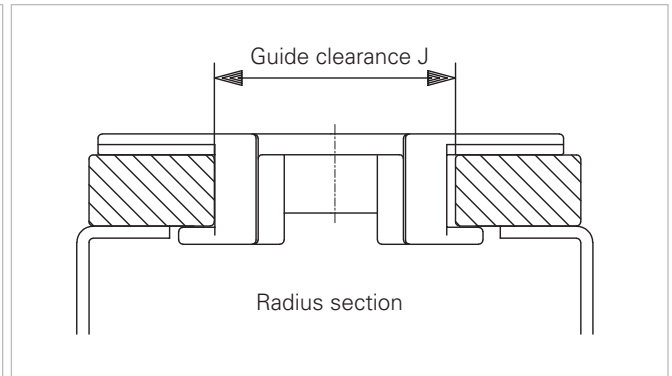
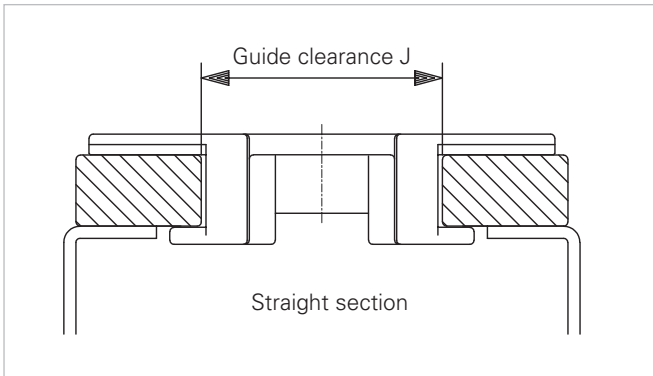
**Chain series:**

Radius running slat top chain, Magnetic chains C0880, C1061

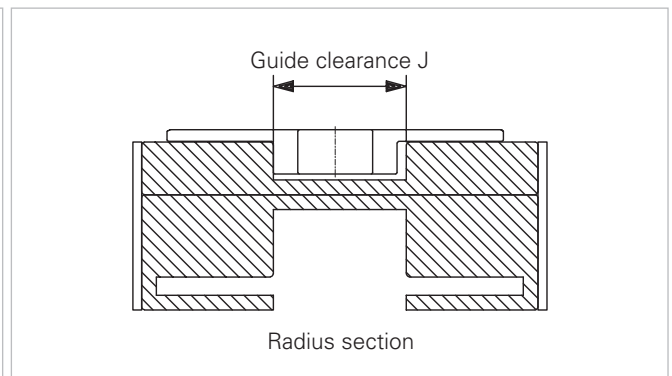
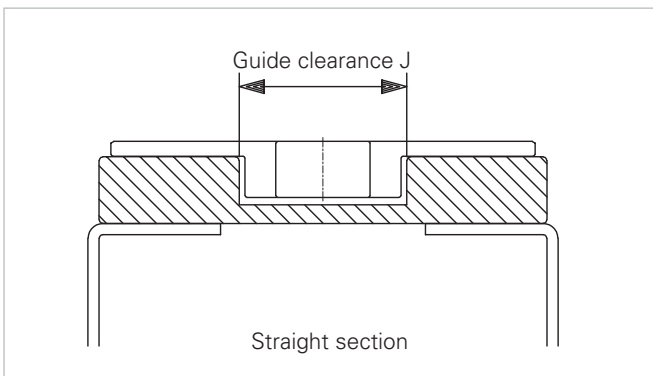
**Chain series:**

Multiflex chains, C1700, 1701, 1702

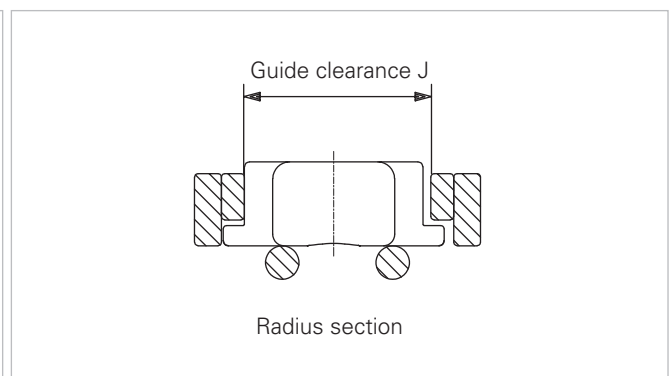
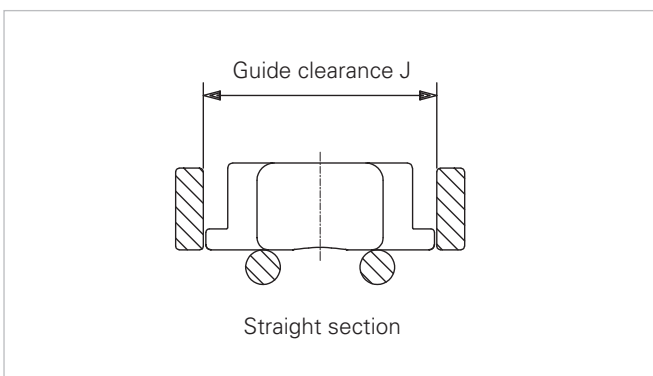

Chain series:

Case chains, no tab (C0040, C0060, C0600, C0601, C1100, C1150, C1200, C1250, C1400, C3200, NH78)

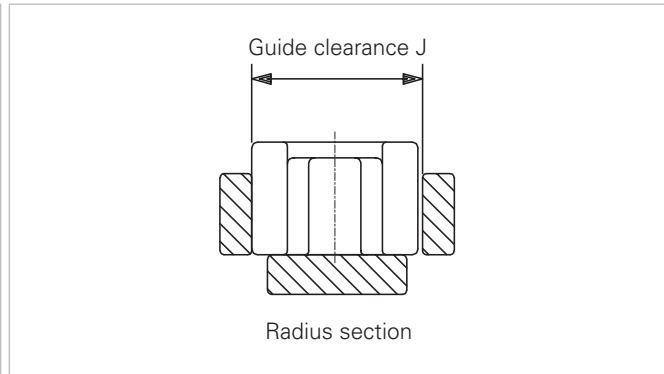
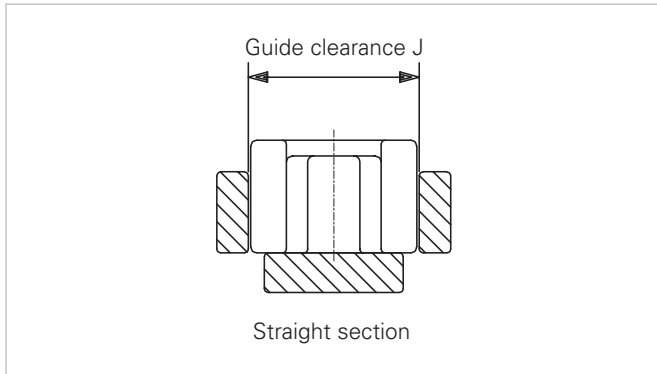
**Chain series:**

Case Chains, tabbed (C0610, C0611, C1110, C1151, C1210, C1251, C1410, C3210)

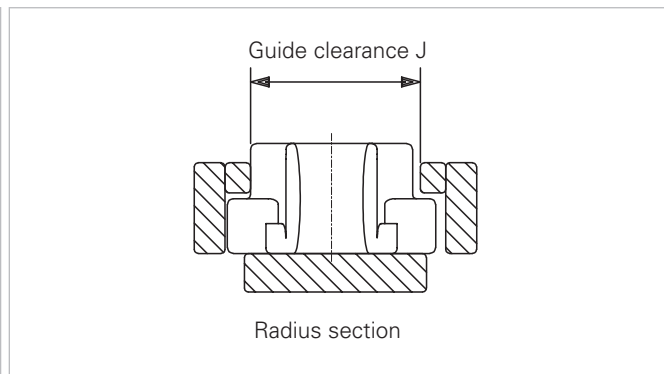
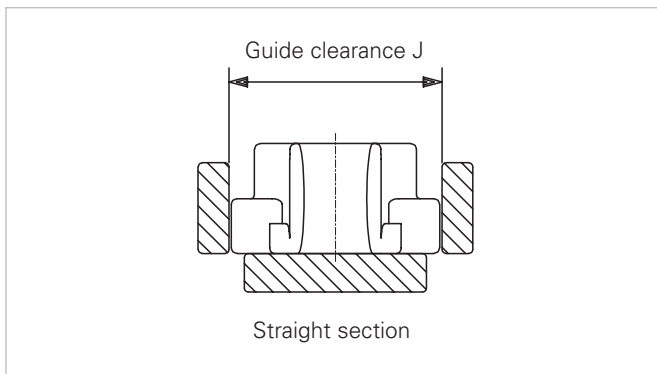

Return side

The following are examples of return ways.

Serpentine return

- This return method for the straight sections fully supports the chain as well as allows drainage and debris to pass through. Top plate wear due to the contact with the wear strip will be even with this style of return
- This style of return can not be used for LBP or Grip top material

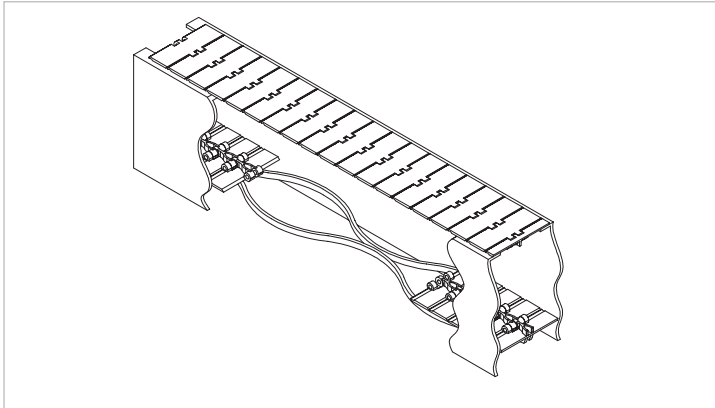

Roller return

- This return method for the straight sections is a very simple design that allows drainage and debris to pass through
- Roller diameters need to be two times the back flex radius of the chain and the rollers must be maintained so that they rotate freely or the top plate will dish, not wear evenly
- Distance between rollers must be staggered to eliminate harmonics with the first roller located after the drive far enough from the drive to allow a catenary pocket
- This style of return can not be used for LBP or Grip top material
- If the roller return infeeds a return curve, a return shoe with a tangent should be used to allow the chain to infeed properly into the curve section

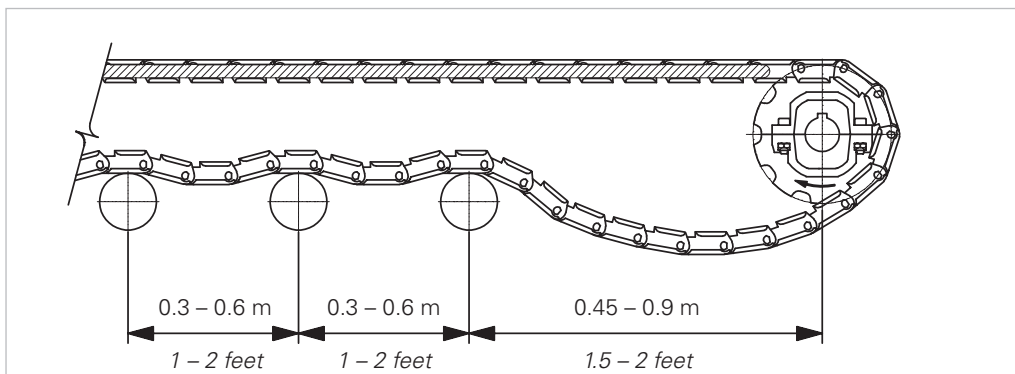

Slider bed

- This return method for straight sections uses a continuous sheet the full width of the chain to support the return way
- If drainage or possible debris build-up is a concern, this method should not be used
- This method of return is suitable for the LBP chains
- If a grip top chain is used, only a slider bed on the edges of the chain where there is no grip insert can be used, allowing clearance between the grip material and the wearstrip

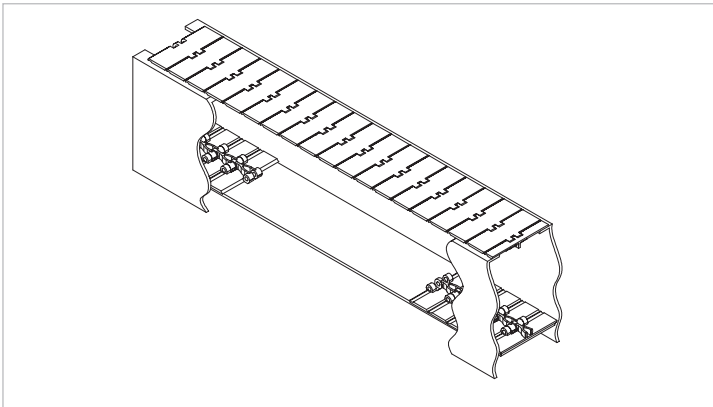

Tab return

- This return method is for both straight and radius sections for chains that have tabs. The tabs are supported by the return wear strips that guide the chains
- The return will not cause any wear to the top plate of the chain

Bevel corner return

- This return corner section is for chains that have a bevel structure
- The chain in the radius uses the inside edge bevel to guide as well as a slider bed to support the chain in the curve

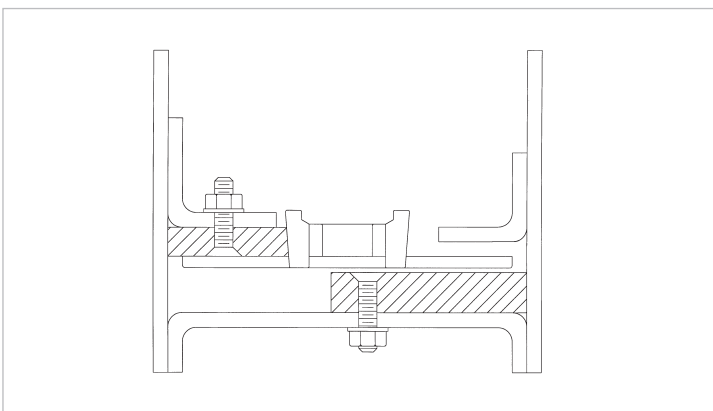

Magnetic chain corner return

- This return corner section is for chains that have a magnetic structure
- The chain is captured by a solid block of wear strip material and uses both the top plate and the hinge area to guide the chain

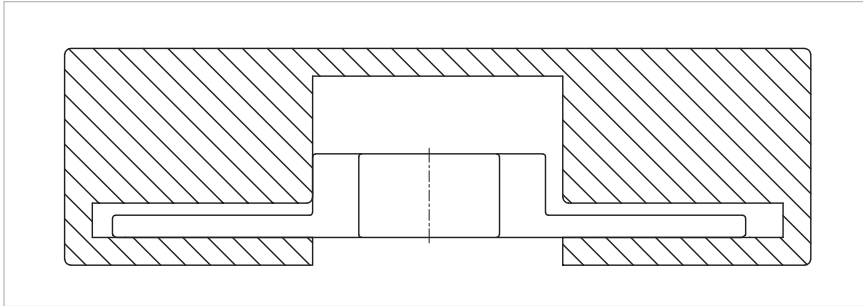

Design guide

HabaCHAIN[®] with HabiPLAST[™] profile

Habasis offers a wide range of HabiPLAST[™] products like extruded profiles, sliding supports and guides, machined tracks, etc. in different materials.

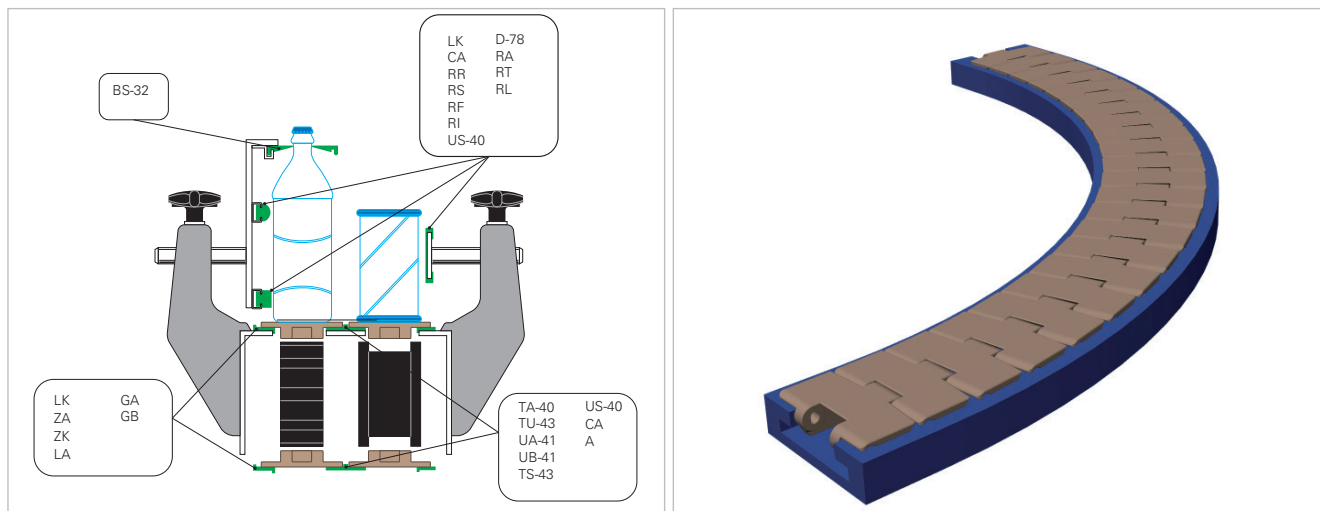

HabaCHAIN[®] with HabiPLAST[™] wear strips

Use the following rules and guidelines to ensure correct selection and assembly of wear strips for chain conveyor applications.

Definition of wear strip and chain designations

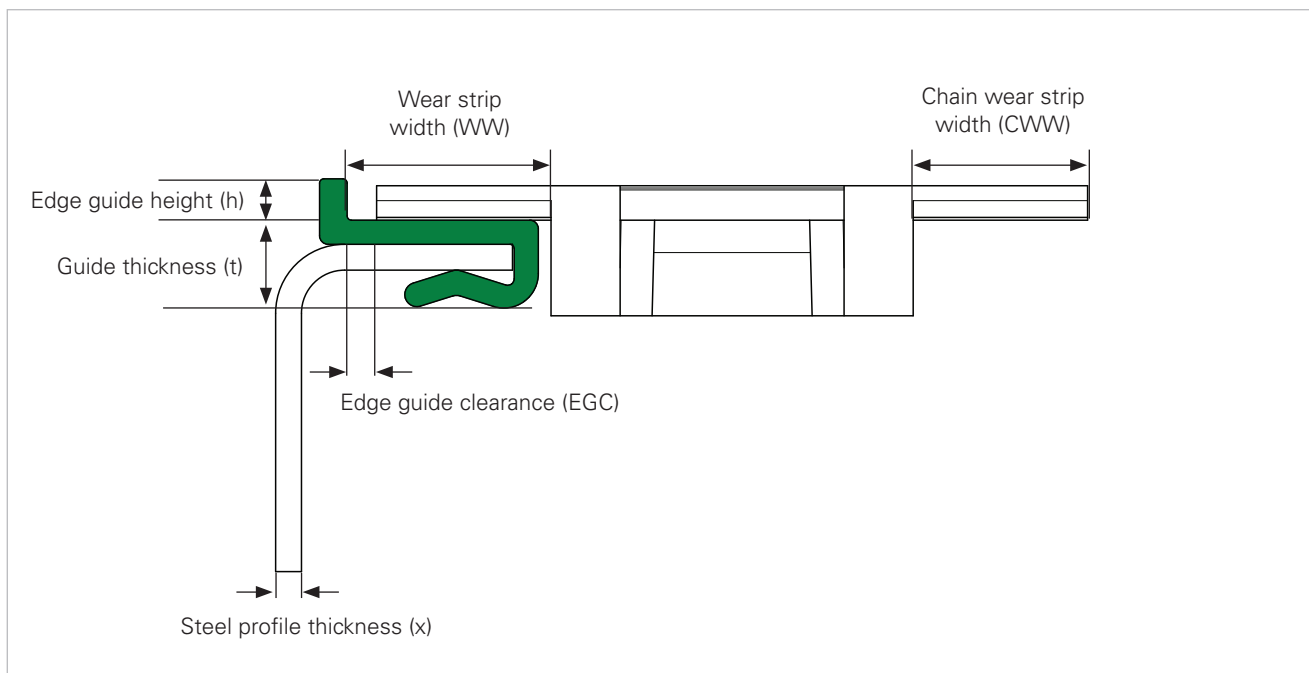

Design guide

HabaCHAIN® with HabiPLAST™ profile

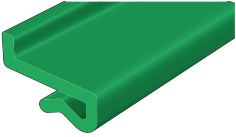
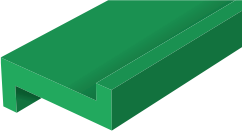
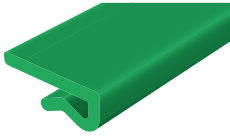
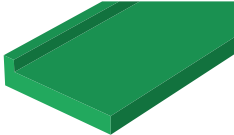
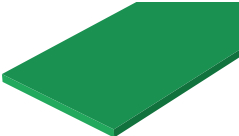
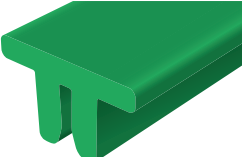
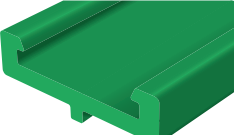
Wear strip type	Description	Example view	Suitability guidelines
Edge guides	Clip on		CWW < WW for all edge guides. The difference equals the clearance (EGC). Exceptions: LC-14 and LC-22 (see note on page 44).
	Z shape		CWW should be: 0.5 mm to 3.0 mm < WW for EGC
Flat guides	Clip on		CWW should be within: 3.0 mm < WW and up to 0.5 mm > WW
	L shape		
	Tape		
T shape (incl. U shape)	T		<p>Intermediate support for wider Slat Top chains. To be used in conjunction with a flat or edge guide to correctly support the chain.</p> <p>For edge guides: clip on and Z shape: CWW = WW – 0.5 mm</p> <p>For flat guides: L shape and clip on: CWW = WW – 3 mm</p> <p>Gap to edge or flat guides: 5 to 30 mm</p> <p>Make sure that there is always a minimum gap between the guides.</p>
	(or U)		Intermediate support for multilane applications. Can be used with metal base profiles CI-16/CIE-16.

Wear strip suitability evaluation

To select the correct wear strip for a chain, use the following table in conjunction with the product guide information. Chain wear strip width information is available on the product data sheet and in the product guide.

Wear strip type	Description	Wear strip width	Chain wear strip width (CWW)		Guide thickness	Edge guide height
		(WW)	Min width	Max width	(t)	(h)
		[mm]	[mm]	[mm]	[mm]	[mm]
ZK-53	Edge guide - Clip on	19.3	16.3	18.8	10.0	2.0
ZK-55	Edge guide - Clip on	21.8	18.8	21.3	10.2	3.2
ZK-57	Edge guide - Clip on	21.8	18.8	21.3	10.2	4.8
ZK-59	Edge guide - Clip on	21.8	18.8	21.3	10.2	7.5
ZA-20	Edge guide - Z shape	18.0	15.0	17.5	5.3	2.3
ZA-23	Edge guide - Z shape	20.0	17.0	19.5	9.0	3.0
ZA-25	Edge guide - Z shape	22.0	19.0	21.5	9.0	3.0
LA-20	Flat - L shape	20.0	17.0	20.5	5.0	N/A
LK-20	Flat - Clip on	20.0	17.0	20.5	10.0	N/A
LK-25	Flat - Clip on	25.4	22.4	25.9	10.2	N/A
LK-40	Flat - Clip on	40.0	37.0	40.5	10.5	N/A
LC-14*	Flat - Clip on	13.8	10.8	14.3	6.0	N/A
LC-22*	Flat - Clip on	22.5	19.5	23.0	6.1	N/A
TP-03	Tape	10.0	7.0	10.5	3.0	N/A
		20.0	17.0	20.5		
		30.0	27.0	30.5		
		40.0	37.0	40.5		
		50.0	47.0	50.5		
		60.0	57.0	60.5		
		70.0	67.0	70.5		
		80.0	77.0	80.5		
		90.0	87.0	90.5		
100.0	97.0	100.5				

*) LC-14 and LC-22 chain wear strip allowable widths do not apply if used with C7100 Flexi chains.

Design guide

HabaCHAIN® with HabiPLAST™ profile

For wider chains where a single wear strip support is not sufficient, use the MT-XX profile to provide intermediate support. To evaluate which profile to combine with the MT-XX, refer to the following tables.

Select the guides to ensure a minimum gap between the wear strips.





Wear strip type	Description	Wear strip width	MT-22, MT-27 MT-32, MT-45 (+33.5)	Chain wear strip width (CWW)	
		(WW)		Min width	Max width
		[mm]		[mm]	[mm]
ZK-53	Edge guide - Clip on	19.3	52.8	57.3	82.3
ZK-55	Edge guide - Clip on	21.8	55.3	59.8	84.8
ZK-57	Edge guide - Clip on	21.8	55.3	59.8	84.8
ZK-59	Edge guide - Clip on	21.8	55.3	59.8	84.8
ZA-20	Edge guide - Z shape	18.0	51.5	56.0	81.0
ZA-23	Edge guide - Z shape	20.0	53.5	58.0	83.0
ZA-25	Edge guide - Z shape	22.0	55.5	60.0	85.0
LA-20	Flat - L shape	20.0	53.5	55.5	80.5
LK-20	Flat - Clip on	20.0	53.5	55.5	80.5
LK-25	Flat - Clip on	25.4	58.9	60.9	85.9
LK-40	Flat - Clip on	40.0	73.5	75.5	100.5
LC-14	Flat - Clip on	13.8	47.3	49.3	74.3
LC-22	Flat - Clip on	22.5	56.0	58.0	83.0
TP-03	Tape	10.0	43.5	45.5	70.5
		20.0	53.5	55.5	80.5
		30.0	63.5	65.5	90.5
		40.0	73.5	75.5	100.5
		50.0	83.5	85.5	110.5
		60.0	93.5	95.5	120.5
		70.0	103.5	105.5	130.5
		80.0	113.5	115.5	140.5
		90.0	123.5	125.5	150.5
		100.0	133.5	135.5	160.5

Steel profile thickness

Wear strips are generally fixed to steel profiles. The steel thickness suitable for the clip on style is shown below.

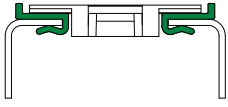
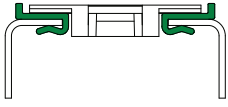
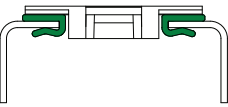
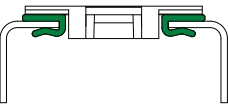
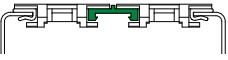
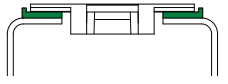
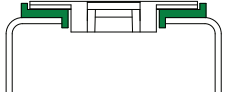
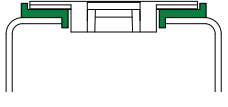
Wear strip type	Description	Steel profile thickness x [mm]
ZK-53	Edge guide - Clip on	2 - 3
ZK-55	Edge guide - Clip on	2 - 3
ZK-57	Edge guide - Clip on	2 - 3
ZK-59	Edge guide - Clip on	2 - 3
ZA-20	Edge guide - Z shape	-
ZA-23	Edge guide - Z shape	-
ZA-25	Edge guide - Z shape	-
LA-20	Flat - L shape	-
LK-20	Flat - Clip on	2 - 3
LK-25	Flat - Clip on	2 - 3
LK-40	Flat - Clip on	2 - 3
LC-14	Flat - Clip on	2.7
LC-22	Flat - Clip on	2.7
TP-03	Tape	-
MT-22	T shape	2,0
MT-27		2.5
MT-32		3.0
MT-45		4.0

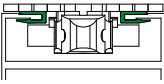
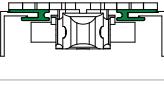
Wear strip suitability for chain types and widths

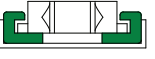
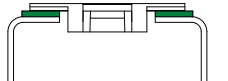
Chain type	Width (inch)	Wear strip series	Wear strip assembly example
C0770, C0810, C0879T, C0880 series, C0890T, C0881T	3.25	ZK-53	
C0820, C0831, C0879 and C0880 series, C0810, C0881B		ZK-55	
C0828, C0810	3.3	ZK-55	
C1061 series, C1071B		ZK-59	
C0770, C0820, C0831, C0879 and C0880 series, C0890T, C0810, C0881 series	3.25	LK-20	
C0863, C0863T, C0963, C0963T, C1873T series, C1874T		LK-25	
C0828, C1061 series, C1071B, C0810	3.3	LK-20	
C0863, C0863T, C0963, C0963T, C1873T series, C1874T	4.5	LK-40	
C0770, C0820, C0831, C0879 and C0880 series, C0890T, C0810, C0881 series, C0828, C1061 series, C1071B	3.25 / 3.3	TS-43 TU-43 US-40	
C0770, C0820, C0831, C0879 and C0880 series, C0890T, C0810, C0881 series	3.25	LA-20	
C0828, C1061 series, C1071B, C0810	3.3		
C0770, C0820, C0831, C0879B, C0880B, C0890T, C0810, C0881 series	3.25	ZA-23	
C0820, C0831, C0879 and C0880 series, C0810, C0881B		ZA-25	
C1061 series, C1071B	3.3	ZA-23	
C1061 series, C1071B, C828, C810		ZA-25	
C0863, C0963, C1873T series, C01874T	6.0	MT-22 MT-27 MT-32 MT-45	
C0820, C0831, C0879 series, C0880 series, C0882 series, C0810, C0881 series, C0863 series, C0963 series, C1873T, C1873T-T, C1874T	7.5		
C0821	10.0		
C0821, C0882 series	12.0		
C7100 (for standard structural profile - industry standard)	2.48 3.25 4.05	LC-14	
C7100 (for non-standard structural profile, customized conveyors)	2.48 3.25 4.05	LC-22	
C1200, C3200, C1201AB	56.9	UA-70	
C1210T, C1211TB, C3210T	56.9	LJ-85	
Various, use wear strip suitability evaluation table	-	TP-03	

Wear strip fixation

Habasisit recommends the following fixations. All fixations require a screw or rivet at the tail end of the wear strip.

Standard

Fixation on the running surface of the profile or tape

- Rivet type: BN 925, countersunk flat top (Bossard ref.)

During installation, ensure that the top surface of the rivet is a minimum of 1 mm below the surface of the profile that guides the chain. See example below:

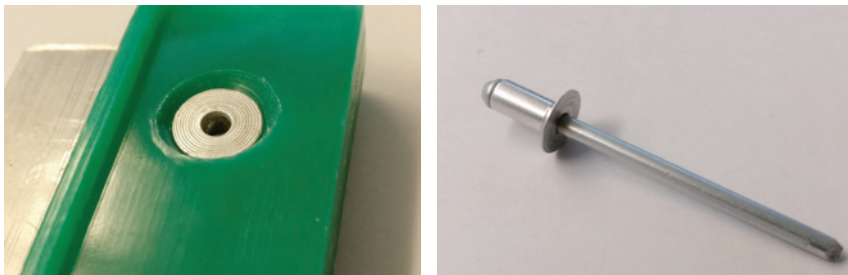

Fixation using a profile with a metallic base profile

- M5 machine screw, countersunk with nut

The profile is fitted to a metal base profile and fixed with a screw as shown below:

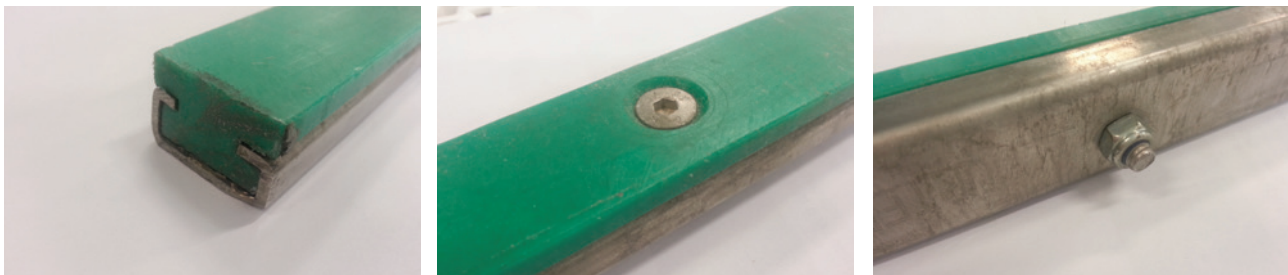

Design guide

HabaCHAIN® with HabiPLAST™ profiles

LC-14 and LC-22 profiles

These profiles are fixed as per the industry standard with plastic screws, whose heads are then cut off flush with the profile as shown below.

Typical replacement procedure (drill hole to 4.5 mm):

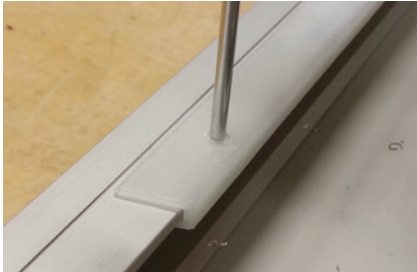

Remove existing profile and screw

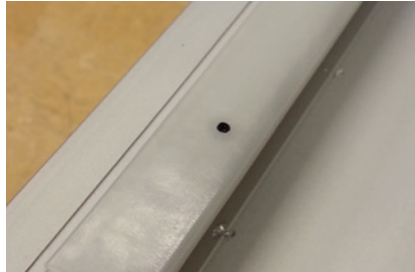

Fit new guide and mark hole position

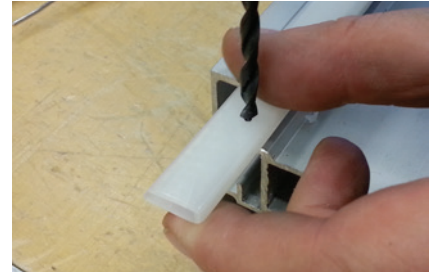

Remove guide, drill hole



Refit guide, fit screw

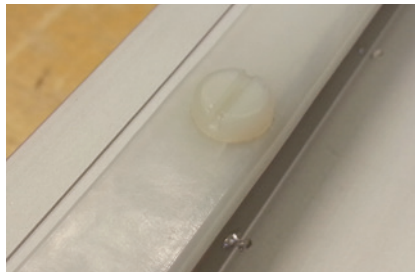

Tighten screw



Cut off screw head



Fitted profile secured by plastic screw, head removed.

T profiles

- Type MT01T: M5 screw and self-locking nut
- The plastic profile is attached directly to the steel conveyor structure

Examples (profile in white material):

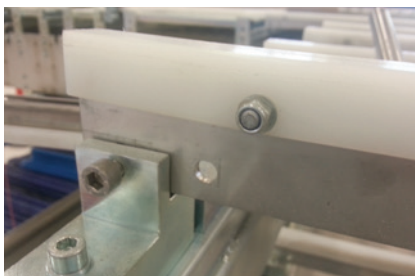

Wear strip length

At elevated temperatures or with high loads, wear strips are susceptible to creep.

Temperature

To reduce the temperature effect, wear strips should be installed at the conveyors' final location. Ideally, the wear strips should be allowed to stabilize for a period of time so that they are at the ambient operating temperature when fitted to the conveyor.

In cases of fluctuating temperatures, the elongation can be calculated using the following formula where d is the distance between wear strips:

$$d > \Delta l = l / 1000 * \alpha * (T - 20 \text{ } ^\circ\text{C})$$

l = Length at installation temperature (20 °C) [mm]
 α = Coefficient of linear thermal expansion
 T = Max. operating temperature [°C]

High loads

Under certain high load conditions, creep can occur when using UHMWPE wear strips. If the vertical loading on the wear strip is greater than 25 kg/m, contact Habasit for recommendations.

Note: for Slat Top, Flexi and Snap-on chains that have two wear strips, the chain transport load can be twice the wear strip load.

Material combinations

Application		HabaCHAIN [®]			HabiPLAST [™]
		Chain	Sprocket		
			Molded	Machined	
Standard	General use	LF, DP, CS	GS	PA	TP40+FE
	General use, wet	LF, DP, SS	GS	PA	PE40 / PE10+RC
	Chemical resistance	PP, SA	na	PE40	PE40 / PE10+RC
	High load, dry	LF	GS	PA	TP40 / PA6C+LF
	High load, wet	LF, SH	GS	PA	PE40 / TP40
	High speed, dry	NG, TS	ND	PA	TP40 / PA6C+LF
	General use	LF	ND	PA	PE40
	ESD (electrostatic dissipative)	EC	GS	PA	TP40+EC / PE40+EC
Abrasive environment	Wet, up to 60 °C (140 °F)	PK	GS	PA	Steel
	Wet, up to 60 °C (140 °F), high load	PK	GS	PA	Steel
	Dry	WR, SA	GS	PA	PA6C+LF / Steel
	Dry, high load	WR, SH	GS	PA	PA6C+LF / Steel
High temperature	Wet, 60 °C to 105 °C (140 °F to 220 °F)	PP	GS	–	Steel
	Dry, high load 93 °C (200 °F)	LF	GS	–	PA6C+LF
	Elevated temperatures 130 °C (266 °F)	HT	CI	–	Steel
	Food contact and temperatures up to 145 °C (293 °F)	SS	CI	–	Steel
	Temperatures up to 170 °C (338 °F)	CS	CI	–	Steel
	Temperatures up to 200 °C (392 °F)	SS/SH/SA	CI	–	Steel

Plastics materials

PE-UHMW (HabiPLAST[™] PE40)

This ultra high molecular weight polyethylene is recommended for demanding lubricated operating conditions.

It is chemically stable and unaffected by moisture. It is not recommended for dry operation on curves where chain load and/or speed is high. Compared to standard extruded PE-HMW the tendency to embed abrasive particles is lower leading to decreased wear on the chain.

Lubricated PE-UHMW (HabiPLAST[™] TriboPlus[®])

HabiPLAST[™] TriboPlus[®] (TP40) represents a new generation of polyethylene with the highest performance in terms of low friction coefficient and wear resistance.

Compared to the standard high-density polyethylene (PE40), laboratory tests showed:

- Reduction of friction and power consumption of about 50%
- Nearly complete absence of wear
- Much higher load limit

Lubricated PA (Habilon PA6C+LF)

Habilon PA6C+LF (polyamide with incorporated lubricants) is recommended for dry applications where a low coefficient of friction is required.

Polyamide expands because of moisture absorption. This has to be considered when using fasteners.

POM (Acetal)

The majority of plastic chains is made of POM (Acetal). The use of wear strips made out of the same material as the chain itself is not recommended.

Plastic wear strips have in general a lower coefficient of friction and a lower thermal conductivity than the metal ones.

Operating conditions

Abrasive materials including broken glass, metal chips, sand, etc. can cause excessive wear to chains and wear strips. Metal wear strips should be used instead of plastic under heavy abrasive conditions.

Wear strip replacement

Replacement criteria for wear strips:

- The thickness is decreased by more than 50% of the original thickness.
- Dirt or debris is embedded in the wear strip material in unacceptable quantities.
- Fixing bolts or blind rivets are protruding the wear strip.

Replace corner tracks before the chain tab is touching the inside of the curve.

Other materials

Lubricant impregnated wood

Used in dry abrasive applications, in particular on glass and paper applications.

Metals

The higher hardness quality makes metal wear strips better suited for abrasive applications.

Carbon steel

Cold-rolled carbon steel is recommended with a low surface roughness. Use hardened or cold-formed steel with at least 25 HRC. Lubricants should contain an antirust agent.

Stainless steel

Cold-rolled stainless steel with a low surface roughness is recommended. Austenitic steels have the better resistance to corrosion than ferritic steels. When plastic chains are used, the stainless steel wear strips should have a hardness of at least 25 HRC. With softer wear strips the two different materials (steel and plastic) may cause the formation of black wear debris.

Bronze and brass

Can be used in non sparking and antistatic conditions, sometimes used with steel chains.

Aluminum

Due to its low wear resistance aluminum is not recommended.

Calculation guide

Chain calculation procedure

After selecting a suitable chain type from the HabaCHAIN® Product Guide, the calculation has to verify and prove the suitability of this chain for the application. For abbreviations, glossary of terms and conversion of units see tables in the Appendix. Use the HabaCHAIN® Calculation Program for detailed calculations.

Before starting the calculation you need to know the following data:

Measure	Unit	Value
Chain type		
Chain width	[mm], [inch]	
Chain material		
Chain speed	[m/min], [ft/min]	
Lubrication	yes/no	
Sprocket teeth		
Drive shaft diameter	[mm], [inch]	
Gearbox efficiency	[%]	
Wear strip material		
Corner track material		
Number of corners		
Product material		
Product load	[kg/m], [lb/ft]	
Product quantity	[pcs/hr]	
Product weight	[kg], [lb]	
Product diameter or length	[mm], [inch]	
Product width	[mm], [inch]	
Product temperature	[°C], [°F]	
Environment temperature	[°C], [°F]	
Abrasive condition	yes/no	
Operation time	[hrs/day]	
Starts + Stops	[qty./day]	
Accumulation	yes/no	
Accumulation length	[mm], [inch]	

Straight conveyor		
Conveyor length	[mm], [inch]	
Inclination height, or	[mm], [inch]	
Inclination angle	[°]	

Radius conveyor (from idle to drive)		
Straight section 1 length	[mm], [inch]	
Radius 1	[mm], [inch]	
Straight section 2 length	[mm], [inch]	
Radius 2	[mm], [inch]	
Straight section 3 length	[mm], [inch]	
Radius 3	[mm], [inch]	
Straight section 4 length	[mm], [inch]	

Does the curves have corner disks?	yes/no	
------------------------------------	--------	--

Appendix

List of abbreviations

1. Symbols for calculations

Term	Symbol	Metric unit	Imperial unit
Coefficient of thermal expansion	α	$\frac{\text{mm}}{\text{m} \cdot ^\circ\text{C}}$	$\frac{\text{inch}}{\text{ft} \cdot ^\circ\text{F}}$
Coefficient of friction chain/support	μ_G	–	–
Coefficient of friction chain/product	μ_P	–	–
Chain width	b_0	mm	inch
Service factor	c_S	–	–
Temperature factor	c_T	–	–
Speed factor	c_V	–	–
Pitch diameter of sprocket	d_P	mm	inch
Shaft diameter	d_W	mm	inch
Modulus of elasticity	E	N/mm ²	lbf/inch ²
Shaft deflection	f	mm	inch
Admissible tensile force	F_{adm}	N	lb
Chain tension caused by the catenary sag	F_C	N	lb
Effective tensile force (chain pull)	F_E	N	lb
Nominal tensile strength	F_N	N	lb
Adjusted tensile force (belt pull) with service factor	F_S	N	lb
Shaft load	F_W	N	lb
Acceleration factor due to gravity	g	9.81 m/s ²	32.2 ft/s ²
Conveying height	h_0	mm	inch
Height of catenary sag	h_C	mm	inch
Inertia	I	mm ⁴	inch ⁴
Distance between conveyor shafts	l_0	m	ft
Conveying distance, horizontal projection	l_1	m	ft
Chain length with accumulated products	l_a	m	ft
Distance between bearings	l_b	mm	inch
Length of catenary sag	l_C	mm	inch
Total geometrical chain length	l_g	mm	inch
Mass of chain/m (chain weight/m)	m_B	kg/m	lb/ft
Mass of product/m (product weight/m)	m_P	kg/m	lb/ft
Chain pitch	p	mm	inch
Power, motor output	P_M	kW	HP
Operation temperature	T	°C	°F
Torque of motor	T_M	Nm	in-lb
Chain speed	v	m/s	ft/min

2. Symbols for illustrations

Term	Symbol	Metric unit	Imperial unit
Level (height) of wear strip in respect to the shaft center	A_1	mm	<i>inch</i>
Keyway width	b	mm	<i>inch</i>
Distance between end of wear strip and sprocket shaft center	C	mm	<i>inch</i>
Catenary sag	CA	–	–
Shaft diameter	$\varnothing d$	mm	<i>inch</i>
Pitch diameter of sprocket	$\varnothing d_p$	mm	<i>inch</i>
Distance pin center plane – top plate back side	E	mm	<i>inch</i>
Distance pin center plane – wear strip	F	mm	<i>inch</i>
Keyway height	h	mm	<i>inch</i>
Motor/drive shaft	M	–	–
Product base diameter	Pb	mm	<i>inch</i>
Roller	R_1, R_2	–	–
Chain support return side	SR	–	–
Wear strip transport side	ST	–	–
Overall height shaft + keyway	t	mm	<i>inch</i>
Take-up device (tensioning device)	TU	–	–
Idling shaft	U	–	–

Appendix

Conversion of units

Metric units		multiply by ... > for imperial units		multiply by ... > for metric units	
Length					
mm	(millimeter)	0.0394	<i>in</i> (<i>inch</i>)	25.4	mm (millimeter)
m	(meter)	3.281	<i>ft</i> (<i>foot</i>)	0.3048	m (meter)
Area					
mm ²	(square-mm)	0.00155	<i>inch²</i> (<i>square-inch</i>)	645.2	mm ² (square-mm)
m ²	(square-m)	10.764	<i>ft²</i> (<i>square-foot</i>)	0.0929	m ² (square-m)
Speed					
m/min	(meter/min)	3.281	<i>ft/min</i> (<i>foot/min</i>)	0.3048	m/min (meter/min)
Mass					
kg	(kilogram)	2.205	<i>lb</i> (<i>pound-weight</i>)	0.4536	kg (kilogram)
Force					
N	(Newton)	0.225	<i>lbf</i> (<i>pound-force</i>)	4.448	N (Newton)
Strength					
N/mm ²	(Newton/sq-mm)	145	<i>psi = lbf/inch²</i> (<i>pound-force/square-inch</i>)	6.89 · 10 ⁻³	N/mm ² (Newton/sq-mm)
Power					
kW	(kilowatt)	1.341	<i>hp</i> (<i>horsepower</i>)	0.7457	kW (kilowatt)
Torque					
Nm	(Newton-meter)	8.85	<i>in-lb</i> (<i>inch-pound</i>)	0.113	Nm (Newton-meter)
Temperature					
°C	(Celsius)	9 · (°C/5)+32)	°F (<i>Fahrenheit</i>)	5/9 · (°F-32°)	°C (Celsius)

Appendix

Material properties – coefficient of friction

Coefficient of friction μ_g between chain and wear strip

Chain material	Lubricant	Wear strip material		
		Stainless steel	PE-UHMW	Lubricated cast nylon
DP	dry	0.23	0.23	0.20
	water	0.20	0.18	n.r.
	lubricant	0.14	0.11	0.10
LF	dry	0.22	0.20	0.18
	water	0.18	0.17	n.r.
	lubricant	0.13	0.10	0.10
PT	dry	0.21	0.19	0.18
	water	0.18	0.17	n.r.
	lubricant	0.13	0.10	0.10
TS	dry	0.20	0.19	0.18
	water	0.17	0.16	n.r.
	lubricant	0.12	0.10	0.10
EC	dry	0.60	0.30	0.26
	water	–	–	n.r.
	lubricant	–	–	–
DE	dry	0.23	0.23	0.20
	water	0.20	0.18	n.r.
	lubricant	0.14	0.11	0.10
PK	dry	0.28	0.25	0.30
	water	0.17	0.16	n.r.
	lubricant	0.12	0.10	0.10
WR	dry	0.30	0.25	n.r.
	water	n.r.	n.r.	n.r.
	lubricant	0.12	0.10	0.10
NY	dry	0.25	0.20	n.r.
	water	0.20	0.15	n.r.
	lubricant	0.12	0.10	0.10
HT	dry	0.25	0.20	n.r.
	water	0.20	0.15	n.r.
	lubricant	0.12	0.10	0.10
NG	dry	0.26	0.16	0.18
	water	0.18	0.15	n.r.
	lubricant	0.12	0.10	0.10
PP	dry	0.30	0.23	0.26
	water	0.18	0.15	n.r.
	lubricant	0.12	0.10	0.10
CR	dry	0.24	0.23	0.20
	water	0.18	0.17	n.r.
	lubricant	n.r.	n.r.	n.r.
NP	dry	0.37	0.27	n.r.
	water	n.r.	n.r.	n.r.
	lubricant	n.r.	n.r.	n.r.
CS	dry	0.50	0.40	0.35
	water	n.r.	n.r.	n.r.
	lubricant	0.20	0.15	0.15
SS – SH – SA	dry	0.50	0.40	0.35
	water	0.40	0.25	n.r.
		0.20	0.15	0.15

n.r. = not recommended

– = not measured

Note

The friction values listed in the above table are based on our in-house testing standards under controlled conditions. The actual coefficient of friction may differ depending on the particular conditions.

Appendix

Material properties – coefficient of friction

Coefficient of friction μ_p between chain and product

Chain material	Lubricant	Product material			
		Returnable glass	Aluminum	Plastic (PET)	Cardboard
DP	dry	0.19	0.18	0.14	0.25
	water	0.17	0.16	0.12	n.r.
	lubricant	0.14	0.12	0.11	n.r.
LF	dry	0.18	0.17	0.13	0.22
	water	0.16	0.15	0.11	n.r.
	lubricant	0.13	0.12	0.10	n.r.
PT	dry	0.17	0.17	0.12	0.24
	water	0.15	0.15	0.11	n.r.
	lubricant	0.12	0.12	0.10	n.r.
TS	dry	0.16	0.16	0.12	0.25
	water	0.15	0.15	0.11	n.r.
	lubricant	0.12	0.11	0.10	n.r.
EC	dry	0.30	0.30	0.20	0.25
	water	–	–	–	n.r.
	lubricant	–	–	–	n.r.
DE	dry	0.19	0.18	0.14	0.25
	water	0.17	0.16	0.12	n.r.
	lubricant	0.14	0.12	0.11	n.r.
PK	dry	0.13	0.16	0.12	0.24
	water	0.12	0.15	0.11	n.r.
	lubricant	0.10	0.12	0.10	n.r.
WR	dry	0.38	–	–	0.30
	water	n.r.	n.r.	n.r.	n.r.
	lubricant	0.16	–	–	n.r.
NY	dry	0.18	0.18	0.20	0.25
	water	n.r.	n.r.	n.r.	n.r.
	lubricant	0.15	0.15	0.15	n.r.
HT	dry	0.18	0.18	0.20	0.25
	water	n.r.	n.r.	n.r.	n.r.
	lubricant	0.15	0.15	0.15	n.r.
NG	dry	0.13	0.13	0.12	–
	water	0.12	0.12	0.11	n.r.
	lubricant	0.10	0.10	0.10	n.r.
PP	dry	0.32	0.32	0.29	0.42
	water	0.25	0.25	0.22	n.r.
	lubricant	0.15	0.15	0.15	n.r.
CR	dry	–	–	–	–
	water	–	–	–	n.r.
	lubricant	n.r.	n.r.	n.r.	n.r.
NP	dry	n.r.	n.r.	n.r.	n.r.
	water	n.r.	n.r.	n.r.	n.r.
	lubricant	n.r.	n.r.	n.r.	n.r.
CS	dry	0.45	0.45	0.31	0.40
	water	n.r.	n.r.	n.r.	n.r.
	lubricant	0.20	0.20	0.17	n.r.
SS – SH – SA	dry	0.40	0.40	0.30	0.40
	water	0.25	0.25	0.23	n.r.
	lubricant	0.20	0.20	0.15	n.r.

n.r. = not recommended

– = not measured

Note

The friction values listed in the above table are based on our in-house testing standards under controlled conditions. The actual coefficient of friction may differ depending on the particular conditions.

Material properties – coefficient of thermal expansion

Coefficient of thermal expansion of the Habiplast™ wear strip material

Habiplast™ material	Coefficient of linear thermal expansion α [mm/(m * °C)]	
	-73 - 30 °C -100 - 86 °F	31 - 100 °C 87 - 210 °F
PE10	0.14	0.20
PE10+RC		
PE40		
PE40+EC		
TP40		
TP40+FE		
TP40+EC		
PA6C+LF	0.08	0.10

Term	Explanation	Habasit symbol
Accumulation conveyor	Conveyor that collects temporary product overflows.	
Accumulation length (distance)	Distance of product accumulation in running direction of the chain.	I_a
Acetal	Polyoxymethylene (POM)	POM
Adjusted tensile force (adjusted chain pull)	Applies a service factor to adjust the effective tensile force calculated near the driving sprocket, taking into account possible inclines and frequent start/stops.	F_s
Admissible tensile force	Force or chain pull allowed near the driving sprocket under process conditions (temperature, speed).	F_{adm}
Back-bending	Negative bending of the chain (opposite of chain bending over sprocket)	
Bi-directional drive	Driving concept allowing to run the chain forward and backward.	
Chain length, inclined	Conveying length measured as vertical projection of distance between the centers of driving and idling shafts.	l_1
Chain length (theoretical)	Length of chain measured around the sprockets including additional length of catenary sag.	l_g
Chain pitch (module pitch)	Center distance between the pivot pins (hinges) of a chain module.	p
Chain width	Geometrical width of the top plate of the chain.	b_0
Carry way	Transport side of the chain, carrying the product.	ST, SR
Catenary sag	Unsupported length of the chain for absorbing chain length variations due to thermal expansion and load changes of chain.	CA
Central drive concept	Motor located on the return way of the chain in-between of the conveyor (for bi-directional drive).	
Chordal action	Polygon effect: Pulsation of the chain velocity caused by the polygon shape of the driving sprocket, with rise and fall of the chain surface.	
Coefficient of friction	Ratio of frictional force and contact force acting between two material surfaces.	μ_G, μ_P
Coefficient of thermal expansion	Ratio of chain lengthening and the product of chain length and temperature change.	α
Dead plate	Metal or plastic plate installed between meeting conveyors as transfer bridge.	
Effective tensile force (effective chain pull)	Calculated near the driving sprocket, where it reaches in most cases its maximum value during operation. It depends on the friction forces between the chain and the slider supports (ST) and (SR) as well as friction against accumulated load.	F_E
Elevating conveyor	Conveyors transporting the products to a higher or lower level, using flights or other suitable means to keep the products in place.	
Flight	Chain module with molded vertical plate for elevating conveyors. The flights prevent the product from slipping back while being moved upwards.	

Term	Explanation	Habasit symbol
Idler	Shaft and sprocket at the chain end opposite to the driving shaft. It is normally equipped with a freewheeling sprocket or idler.	
Mass of chain (chain weight per length)	The chain mass (weight) is added to the product mass per [m] or [ft] for calculation of the friction force between chain and wear strip.	m_B
Mass of product (product weight per length)	Conveyed product weight as expected to be distributed over the chain length; calculated average load in [kg/m], [lb/ft].	m_p
Nominal tensile strength	Catalogue value. It reflects the maximum allowable chain pull at room temperature and very low speed.	F_N
Pitch diameter	Diameter of the sprocket which defines the position of the pins of the driven chain.	$\varnothing d_p$
Polygon effect	Chordal action: Pulsation of the chain velocity caused by the polygon shape of the driving sprocket, with rise and fall of the chain surface.	
Radius chain	Chain suitable for running around curves (radius applications).	
Screw type take-up	The catenary sag is adjusted by means of a screw tensioning device at the idling shaft of the conveyor.	
Service factor	The calculated effective chain pull is adjusted with the service factor taking into account possible heavy running conditions (start/stop, inclination).	c_s
Slat Top chain	The top plate of the chain is flat and closed (no openings, no flights).	
Slider support	Frame equipped with wear strips to carry the running chain with low friction and wear.	ST, SR
Speed factor	The nominal tensile force, valid at very low speed and room temperature, is reduced to the admissible tensile force by the influence of higher speed and/or temperature; therefore it is multiplied with the respective factor.	c_v
Sprocket	Gear, mostly plastic, in exceptional cases made of metal, shaped to engage the chain, providing positive torque transmission to the chain.	
Tab	"Hook" shaped tabs on the bottom of the radius chain, running below a guide rail. Prevent the chain from lifting out of the base in the curve.	
Take-up	Tensioning device for adjustment of the catenary sag, screw type, gravity type or spring loaded type at the idling shaft of the conveyor	TU
Temperature factor	The nominal tensile force, valid at very low speed and room temperature, is reduced to the admissible tensile force by the influence of higher speed and/or temperature; therefore it is multiplied with the respective factor.	c_T
Transport length	Conveying length measured between the centers of driving and idling shafts.	l_0
Transport side	Carry way of the chain, carrying the product.	
Wear strip	Sliding strip, mainly made of plastic, used on the conveyor frame to provide low friction and low wear.	

Rapid or unusual wear of the chain

Possible cause	Proposed measures
Sprocket misalignment	Correct the shaft mounting position and sprocket alignment.
Obstruction cutting or scraping the chain	Locate the origin of the cutting and remove the obstruction. Replace any wear strips that have foreign particles embedded in them.
Grooved wear strips	Remove abrasive build-up or replace wear strips with a harder material (if necessary).
Inadequate guide clearance in which guide tracks may be interfering with the chain	Make sure that there are no tight spots. Check to assure that proper guide clearances are provided. Pull a short piece of chain through the tight section before reinstallation. Check that there is a smooth transition between straight and curved sections. Also ensure that there is clearance for the tabs throughout the entire conveyor.
Chain is riding uneven in the track	Check to insure the wear strips are even and level. Modify the wear strips as required by adding or deleting shims.
Improper return roller diameter	Refer to the HabaCHAIN® Product Guide and the Product Data Sheets for the minimum back-bending radius.
Return roller has stopped spinning freely	Ensure that all return rollers are spinning freely.

Notes

- Unusual wear patterns on the top of the chain usually indicate return way problems
- Unusual wear patterns on the bottom of the chain usually indicate transport side problems
- Excessive wear on the thrust surface of the chain usually indicates corner track or disc problems

Chemical attack

Plastic chains appear cracked or discolored (white residue is found on the chain)

Possible cause	Proposed measures
Chemical attack due to product spillage	Refer to the chapter “Chemical Resistance” of the HabaCHAIN® Product Guide.
Use of strong chemical cleaners or lubricants	Review your methods of cleaning.

Excessive sprocket wear

Possible cause	Proposed measures
Abrasive environment	Clean conveyors frequently to reduce the amount of abrasives present. Review the sprocket material options.
Incorrect “A1” and “C” dimensions	Correct the shaft mounting position and sprocket alignment.

Excessive chain wear

Possible cause	Proposed measures
Abrasive material	Improve cleaning or add protective shields to reduce the amount of abrasive material contacting the chain and sprocket.
Incorrect chain and/or wear strip material	Check material specifications to ensure that the optimal material is used. Call Habasit technical service for a recommendation.
Method of product loading	Reduce the distance that product is deposited on the chain. If product sliding occurs, refer to material specifications.
High chain speed	High chain speeds will increase the wear especially on conveyors with short centerline distances. Reduce chain speed if possible.

Premature chain elongation

Possible cause	Proposed measures
Abrasive material	Improve cleaning or add protective shields to reduce the amount of abrasive material contacting the chain and sprocket.
Incorrect tension	Adjust.
High temperatures	High temperatures cause the chain to elongate a large percentage. Check if the catenary sag is long enough to compensate the elongation.

Broken top plates or tabs

Possible cause	Proposed measures
Obstructions in conveyor frame, product jam or improper guide clearance	Locate and remove obstruction. Check guide clearance. Replace broken links if required.
Tight corner radius	Make sure corner tracks (or discs) comply with the minimum side flexing radius of the chain.
Chemical attack	Refer to the chapter "Chemical Resistance" of the HabaCHAIN® Product Guide.
Impact loading	Remove the source of impact loading. Consult Habasit technical service for proper chain selection for applications involving impact loading.

Chain is squealing

Possible cause	Proposed measures
Chain is trying to pass through a tight section of the conveyor	Make sure that there are no tight spots. Check to assure that proper guide clearances are provided. Pull a short piece of chain through the tight section before reinstallation. Make sure that there is a smooth transition between straight and curved sections. Also ensure that there is clearance for the tabs throughout the entire conveyor.
Improper curve radius	Make sure corner tracks (or discs) comply with the minimum side flexing radius of the chain.
Rough surface finish on the inside corner track	Check to ensure that there is a smooth finish on the wear strips where they contact the chain (i.e. no rough saw cuts or machining marks). Replace corner tracks if necessary.
Improper corner track material selection	Check if there are foreign particles embedded in the corner tracks. Habilon or metal may provide a harder surface.
Improper corner track selection	Selective lubrication or corner discs may be required.
Vibration within conveyor frame	Make sure conveyor structure is solid.

Appendix

Chemical resistance – Plastics

The data presented in the following table is based on information provided by the raw material manufacturers and suppliers. It does not replace the need to test the products for your application.

In individual cases, the stability of the material in the medium in question must be examined.

Code: ■ = good resistance ▼ = limited use □ = not recommended

Materials	PP		PE		DP-LF-PT-TS PK-EC-DE		WR-NY-HT L pin-GS		ND		G		NG-NP-N pin	
	20 °C (70 °F)	60 °C (140 °F)	20 °C (70 °F)	60 °C (140 °F)	20 °C (70 °F)	60 °C (140 °F)	20 °C (70 °F)	60 °C (140 °F)	20 °C (70 °F)	60 °C (140 °F)	20 °C (70 °F)	60 °C (140 °F)	20 °C (70 °F)	60 °C (140 °F)
Acetic Acid > 5%	■	■	■	▼	▼	□	□	□	□		□		▼	□
Acetic Acid – 5%	■	■	■	■	■		▼	□	□		□		■	▼
Acetone	■	■	■	■	▼	▼	■	■			□		▼	□
Alcohol – all types	■	■	■	■	■	▼	■	■	□		▼		■	▼
Aluminum Comp.	■	■	■	■			■	■						
Ammonia	■	■	■	■	■	■	■	■	■				▼	□
Ammonium Comp.	■	■	■	■			■	■					▼	□
Aniline	■	■	■	□		▼			□				▼	
Aqua Regia	□	□	▼	□			□	□						
Arsenic Acid	■	■	■	■										
Barium Comp.	■	■	■	■			■	■						
Beer	■	■	■	■	■				■					
Benzene	▼	□	▼	□	▼	▼	■	■	□				▼	□
Benzenesulfonic Acid – 10%	■	■	■	■										
Benzoic Acid	■	■	■	■			▼	▼	■					
Beverages (soft drinks)	■	■	■	■	■	■	■	■						
Borax	■	■	■	■										
Boric Acid	■	■	■	■			■	■	■					
Brine – 10 %	■	■	■	■	■	■								
Butyl Acrylate	□	□	■	▼									■	▼
Butyric Acid	■		■	▼			■	■	■					
Carbon Dioxide	■	■	■	■			■	■					■	■
Carbon Disulfide	▼	□	▼	□			■	■						
Carbon Tetrachloride	▼	□	▼	□	■	▼	■	■	□					
Chloracetic Acid	■	■					□	□						
Chlorine – Gas	□	□	▼	□	□	□	□	□	□					
Chlorine – Liquid	□	□	□	□	□	□	□	□	□					
Chlorine Water (0.4% Cl)	■	▼	■	▼	□	□	□	□						
Chlorobenzene	□	□	▼	□	▼	▼	■	■	□				□	
Chloroform	□	□	□	□	□	□	▼						□	
Chromic Acid – 50%	■	■	■	▼	□	□	▼		▼					
Chromic Acid – 3%	■	■	■	■	▼	▼							■	■
Citric Acid – 40%	■	■	■	■	■	□	■	■	■					

Appendix

Chemical resistance – Plastics

Code: ■ = good resistance ▼ = limited use □ = not recommended

Materials	PP		PE		DP-LF-PT-TS PK-EC-DE		WR-NY-HT L pin-GS		ND		G		NG-NP-N pin	
	20 °C (70 °F)	60 °C (140 °F)	20 °C (70 °F)	60 °C (140 °F)	20 °C (70 °F)	60 °C (140 °F)	20 °C (70 °F)	60 °C (140 °F)	20 °C (70 °F)	60 °C (140 °F)	20 °C (70 °F)	60 °C (140 °F)	20 °C (70 °F)	60 °C (140 °F)
Citric Acid – 10%	■	■	■	■	■		■	■	■				■	▼
Citrus Juices	■	■	■	■	■		■	■					■	
Coconut Oil	■	■	■	■	■	■	■		■				■	■
Copper Comp.	■	■	■	■			▼							
Corn Oil	■	■	■	■	■	■	■						■	■
Cottonseed Oil	■	■	■	■	■	■	■		■				■	■
Cresol	■	■	■	▼			□	□	□					
Cyclohexane	■	▼	□	□			■		▼					
Cyclohexanol	■	▼	▼	□			■		□					
Cyclohexanone	■	▼	□	□			■		□					
Detergents	■	■	■	■	■	■	■		■		■		■	■
Dextrin	■	■	■	■										
Dibutyl Phthalate	■	▼					■	■						
Diethyl Ether	□	□	□	□	▼	▼	■	■					■	▼
Diethylamine	■	■		□										
Diglycolic Acid – 30%	■	■	■	■										
Diisooctyl Phthalate	■	■												
Dimethyl Phthalate	■	■												
Dimethylamine	■						■	■						
Dioctyl Phthalate	■	▼					■	■						
Ethyl Acetate	■	■	▼	▼	▼	□	■	■	□		□		▼	□
Ethyl Ether	▼	▼							□					
Ethylamine	■	■												
Ethylene Glycol – 50%	■	■	■	■	■	▼	■	▼					■	▼
Ferric/Ferrous Comp.	■	■	■	■	▼	□								
Formaldehyde – 37%	■	■	■	▼	■	■			□		▼			
Formic Acid – 85%	■	▼	■	■			▼	□	□		□		▼	□
Freon			■	■	▼	▼								
Fuel Oil # 2	■	▼	■	□	▼	▼	■	■	■		□		■	■
Fruit Juices	■	■	■	■	■		■		■				■	
Furfural	▼	▼	▼	□			■							
Gasoline	▼	□	■	□	■	■	■	■						
Glucose	■	■	■	■	■	■			■					
Glycerol	■	■					■	■	▼		▼		■	■
Heptane	□	□	▼	□	■	■	■	■	■				■	■
Hexane	■	▼	□	□	■		■	■	■				■	■
Hydrobromic Acid – 50%	■	■	■	■			□	□						

Appendix

Chemical resistance – Plastics

Code: ■ = good resistance ▼ = limited use □ = not recommended

Materials	PP		PE		DP-LF-PT-TS PK-EC-DE		WR-NY-HT L pin-GS		ND		G		NG-NP-N pin	
	20 °C (70 °F)	60 °C (140 °F)	20 °C (70 °F)	60 °C (140 °F)	20 °C (70 °F)	60 °C (140 °F)	20 °C (70 °F)	60 °C (140 °F)	20 °C (70 °F)	60 °C (140 °F)	20 °C (70 °F)	60 °C (140 °F)	20 °C (70 °F)	60 °C (140 °F)
Hydrochloric Acid – 35%	■	■	■	■	□	□	□	□	▼					
Hydrochloric Acid – 10%	■	■	■	■	□	□	□	□	▼		▼		■	□
Hydrofluoric Acid – 35%	■	■	■	■	□	□	□	□	□				□	
Hydrogen Peroxide – 3%	■	■	■	■	■	■	▼	▼	▼		■		■	▼
Hydrogen Peroxide – 90%	▼	▼	■	▼	▼	□	□	□	□				■	□
Hydrogen Sulfide	■	■	■	■			■	■						
Igepal – 50%	■	■			■	▼								
Iodine – Crystals	■	■	▼	▼	□	□	□	□	□					
Isooctane	□	□	■				■	■	■				■	■
Isopropyl Alcohol	■	■	■	■	■	■	■	■	□		▼		■	▼
Jet Fuel	▼	□	▼	▼	■	■	■	■			□		■	■
Kerosene	▼	□	▼	▼	■	■			■		□			
Lactic Acid	■	■	■	■	■	□	▼	□						
Lanolin	■	▼	■	■	■	■							■	■
Lauric Acid	■	■	■	■										
Lead Acetate	■	■	■	■			■	■						
Linseed Oil	■	■	■	■	■	■	■	■	■				■	■
Lubricating Oil	■	▼			■	■	■	▼	■		□		■	■
Magnesium Comp.	■	■	■	■			■	■						
Malic Acid – 50%	■	■	■	■			■	■						
Manganese Sulfate	■		■	■			▼	▼						
Margarine	■	■	■	■										
Mercury	■	■	■	■			■						■	
Methyl Chloride	▼	▼					■	■					□	
Methyl Ethyl Ketone	■	▼	□	□	▼	▼	■		□		□		□	□
Methyl Isobutyl Ketone	■	▼												
Methylsulfuric Acid	■	■	■	■										
Methylene Chloride	▼	□	□	□			▼	▼	□		□			
Milk	■	■	■	■	■	■	■	■	■					
Mineral Oil	▼	□	■	▼	■	■	■		■		□		■	■
Mineral Spirits	▼	□									□		■	■
Molasses	■	■	■	■			■	■						
Motor Oil	■	▼			■	■	■	■	■		□		■	■
Naphtha	■	▼	▼	□			■	■						
Nitric Acid – 30%	■	▼	■	■	□	□	□	□	▼				□	
Nitric Acid – 50%	▼	□	■	▼	□	□	□	□	▼				□	
Nitrobenzene	■	▼	□	□			▼							

Appendix

Chemical resistance – Plastics

Code: ■ = good resistance ▼ = limited use □ = not recommended

Materials	PP		PE		DP-LF-PT-TS PK-EC-DE		WR-NY-HT L pin-GS		ND		G		NG-NP-N pin	
	20 °C (70 °F)	60 °C (140 °F)	20 °C (70 °F)	60 °C (140 °F)	20 °C (70 °F)	60 °C (140 °F)	20 °C (70 °F)	60 °C (140 °F)	20 °C (70 °F)	60 °C (140 °F)	20 °C (70 °F)	60 °C (140 °F)	20 °C (70 °F)	60 °C (140 °F)
Nitrous Acid	■													
Nitrous Oxide	■													
Oleic Acid	■	□			■	■	■	■						
Olive Oil	■	■	■	■					■		□		■	■
Oxalic Acid	■	■	■	■					■					
Ozone	▼	▼	▼	□	□	□	▼	▼	■					
Palmitic Acid – 70%	■	■	■	■			■							
Paraffin	■	■	■	■	■	■	■	■	■		▼			
Peanut Oil	■	■					■		■		□			
Perchloric Acid – 20%	■	■	■	■										
Perchloroethylene	□	□	□	□			▼	□					■	□
Pathalic Acid – 50%	■	■	■	■										
Phenol	■	■	■	■	□	□	□	□	□					
Phenol – 5 %	■	■	■	■	□	□	□	□					▼	□
Phosphoric Acid – 30%	■	■	■	■	▼	□	□	□					■	□
Phosphoric Acid – 85%	■	■	■	■	□	□	□	□					■	□
Photographic Solutions	■	■	■	■			■							
Plating Solutions	■	■	■	■										
Potassium Comp.	■	■	■	■	■	■	▼		■				■	■
Potassium Hydroxide	■	■	■	■	■	■	▼						□	
Potassium Iodide (3% Iodine)	■	■	■	■										
Potassium Permanganate	■	▼	■	■			□	□						
Silver Cyanide	■	■												
Silver Nitrate	■	■	■	■										
Sodium Comp.	■	■	■	■										
Sodium Chlorite	■	▼	■	■	■	■	□	□						
Sodium Hydroxide – 60%	■	■	■	■	□	□	□	□	▼		▼		□	
Sodium Hypochlorite – 5%	■	▼	■	▼	□	□	▼						■	▼
Stearic Acid	■	▼	■	■	▼		■	■						
Sulfamic Acid – 20%	■	■			□	□								
Sulfate Liquors	■	■												
Sulfur	■	■	■	■			■	■						
Sulfur Chloride	■													
Sulfur Dioxide	■	■	■	■	□	□	▼	▼						
Sulfuric Acid – 10%	■	■	■	■	■	□	□	□	▼		■		■	■
Sulfuric Acid – 50%	■	■	■	■	□	□	□	□	▼		■		▼	
Sulfuric Acid – 70%	■	▼	■	▼	□	□	□	□	▼				□	

Appendix

Chemical resistance – Plastics

Code: ■ = good resistance ▼ = limited use □ = not recommended

Materials	PP		PE		DP-LF-PT-TS PK-EC-DE		WR-NY-HT L pin-GS		ND		G		NG-NP-N pin	
	20 °C (70 °F)	60 °C (140 °F)	20 °C (70 °F)	60 °C (140 °F)	20 °C (70 °F)	60 °C (140 °F)	20 °C (70 °F)	60 °C (140 °F)	20 °C (70 °F)	60 °C (140 °F)	20 °C (70 °F)	60 °C (140 °F)	20 °C (70 °F)	60 °C (140 °F)
Sulfurous Acid	■		■	■			▼	▼						
Tannic Acid – 10%	■	■	■	■										
Tartaric Acid	■	■	■	■			■	▼	■					
Tetrahydrofuran	▼	□			▼	▼	■							
Toluene	□	□	□	□	▼	□	■	■	▼				■	□
Transformer Oil	■	▼	■	▼			■	■	■		□			
Tributyl Phosphate	■	▼												
Trichloroacetic Acid	■	■	▼				□	□						
Trichloroethylene	□	□	□	□	▼	▼	▼	□	□				▼	□
Tricresyl Phosphate	■	▼												
Trisodium Phosphate	■	■	■	■										
Turpentine	▼	□	■	□	■		■	■	▼				■	■
Urea	■	■	■	■	■		■	■	■				■	
Vinegar	■	■	■	■	■	■	■	■	▼					
Wine	■	■	■	■	■	■	■							
Xylene	□	□	□	□	■	■	■	■	▼				▼	□
Wine	■	■	■	■	■	■	■							
Xylene	□	□	□	□	■	■	■	■	▼				▼	□

The data in this table is taken from laboratory tests, performed on unstrained test samples. It should be considered as purely indicative, since material behavior under real working conditions depends on different factors, including: temperature, concentration of the chemical agent, and speed or long-lasting effect of the chemical agent.

With thermoplastic products, do not use cleaning or lubricating agents with pH values below 4 or above 10.

Appendix

Chemical resistance – Steel

Code: ■ = good resistance ▼ = limited use □ = not recommended

Materials	SS		SH		SA		IN	
	20° C (70 °F)	60 °C (140 °F)	20° C (70 °F)	60 °C (140 °F)	20° C (70 °F)	60 °C (140 °F)	20° C (70 °F)	60 °C (140 °F)
Acetic Acid > 5%	□		■	■				
Acetic Acid – 5%	□		■	■				
Acetone	■		■	■				
Alcohol – all types	■		■	■				
Aluminum Comp.			□	□				
Ammonia	■		■	■				
Aniline	■		■	■				
Aqua Regia			□	□				
Beer	■		■	■				
Benzene	▼		■	■				
Benzoic Acid			■	■				
Beverages (soft drinks)			■	■				
Borax			■	■				
Boric Acid	▼		■	■				
Brine – 10%	□		▼	□				
Butter	■		■					
Carbon Dioxide			■	■				
Carbon Disulfide								
Carbon Tetrachloride	■		■	■				
Chlorine – Gas			■	■				
Chlorine – Liquid	□		□	□				
Chloroform	▼		■	■				
Citric Acid – 40%	▼		▼	□				
Citric Acid – 10%	■		■	■				
Distilled water	■		■	■				
Ethyl Ether			■	■				
Ferric/Ferrous Comp.			□	□				
Formaldehyde – 37%	■		■	■				
Formic Acid – 85%	▼		■	■				
Fruit Juices	■		■	■				
Gasoline	■		■	■				
Glucose			■	■				
Glycerol	■		■	■				
Hydrobromic Acid – 50%			□	□				
Hydrochloric Acid – 35%	□		□	□				
Hydrochloric Acid – 10%	□		□	□				
Hydrofluoric Acid – 35%			□	□				
Hydrogen Peroxide – 3%	■		■	■				
Hydrogen Peroxide – 90%	▼		■	■				
Hydrogen Sulfide			■	■				
Iodine – Crystals			■	■				
Kerosene			■	■				
Lactic Acid	▼		■	■				
Lead Acetate			■	■				
Linseed Oil			■	■				
Magnesium Comp.			▼	□				
Malic Acid – 50%			■	■				
Margarine			■	■				
Mercury	▼		■	■				
Methyl Ethyl Ketone			■	■				
Methylene Chloride	▼		▼	□				
Milk	■		■	■				
Mineral Oil	■		■	■				
Motor Oil			■	■				
Nitric Acid – 25%	▼		■	■				
Nitric Acid – 50%	□		■	■				
Oleic Acid	▼							
Olive Oil	■		■	■				
Oxalic Acid			□	□				
Ozone			■	■				
Palmitic Acid – 70%			■	■				
Phenol			■	■				
Phosphoric Acid – 25%	▼		■	■				
Phosphoric Acid – 50%	□		■	■				
Photographic Solutions			■	■				
Potassium Hydroxide	■		■	■				
Silver Nitrate			■	■				
Soap and water	■		■	■				
Sodium Chlorite	▼		■	■				
Sodium Hydroxide	■		■	■				
Sodium Hydroxide – 60%			▼	▼				
Sodium Hypo-chlorite (5% Cl)			▼	▼				
Sulfur			■	■				
Sulfur Dioxide (dry)			■	■				
Sulfur Dioxide (wet)			□	□				
Sulfuric Acid – 10%	□		□	□				
Sulfuric Acid – 50%	□		□	□				
Sulfuric Acid – 70%	□		□	□				
Tannic Acid – 10%			■	■				
Tartaric Acid	■		■	■				
Toluene	■		▼	▼				
Transformer Oil			■	■				
Turpentine	■		■	■				
Urea	■		■	■				
Vinegar	■		■	■				
Whisky	▼		■	■				
Wine	■		■	■				
Xylene	■		■	■				

When connecting or disconnecting a chain, always turn off and lock out the power switch before starting. Always use goggles to protect your eyes. Wear protective clothing, gloves and safety shoes. Support the chain to prevent uncontrolled movements. Use appropriate tools in good working condition, and use them correctly in a proper manner. Do not attempt to connect or disconnect the chain without full knowledge of the chain construction, including the correct procedure for pin removal or insertion.

All pinch and shear points, along with all other exposed moving parts that pose a potential hazard to people at workstations or on conveyor passageways, must be safeguarded.

Overhead conveyors must have guards to prevent objects from falling. Cleated conveyor chains are more hazardous, creating pinch and shear points.

Safeguarding can be achieved by:

Identification

Identify all hazardous areas that pose a danger to personnel.

Guard barriers

Place guard barriers to prevent entry into the hazardous area, and apply guards to high conveyors to prevent objects from falling on to personnel below.

Control devices

Set machine controls to prevent hazardous operations/conditions.

Warnings

Use instructions, warning labels, or sound/light signals to alert that a hazardous condition exists.

Safeguarding should be designed to minimize any discomfort or difficulties for operators. Bypassing and/or overriding safeguarding mechanisms during operation should not be allowed.

Any safeguarding concerns regarding the conveyor should be addressed during the design process.

Product safety

Products designed and manufactured by Habasit can

be used in a safe manner; but Habasit cannot warrant their safety under all circumstances. PURCHASER MUST INSTALL AND USE THE PRODUCTS IN A SAFE AND LAWFUL MANNER IN COMPLIANCE WITH APPLICABLE HEALTH AND SAFETY REGULATIONS AND LAWS AND GENERAL STANDARDS OF REASONABLE CARE; AND IF PURCHASER FAILS TO DO SO, PURCHASER SHALL INDEMNIFY HABASIT FROM ANY LOSS, COST OR EXPENSE RESULTING DIRECTLY OR INDIRECTLY FROM SUCH FAILURE. SAFETY DEVICES: Products are provided with only the safety devices identified herein. IT IS THE RESPONSIBILITY OF PURCHASER TO FURNISH APPROPRIATE GUARDS FOR MACHINERY PARTS IN COMPLIANCE WITH MSHA OR OSHA STANDARDS, AS WELL AS ANY OTHER SAFETY DEVICES DESIRED BY PURCHASER AND/OR REQUIRED BY LAW; AND IF PURCHASER FAILS TO DO SO, PURCHASER SHALL INDEMNIFY HABASIT FROM ANY LOSS, COST OR EXPENSE RESULTING DIRECTLY OR INDIRECTLY FROM SUCH FAILURE.

General safety precautions

- To avoid personal injury, all machinery must be turned off and locked out, prior to chain installation, inspection, maintenance and removal
- Always use safety glasses to protect eyes. Wear protective clothing, gloves and safety shoes
- Support the chain to prevent uncontrolled movement of the chain and parts
- Maintain tools in proper condition and ensure their proper use. Use of chain assembly tools is recommended when applicable
- Do not attempt to connect or disconnect chain unless chain construction is clearly known and understood
- Do not use any sections of damaged chains, because they may have been overloaded and yielded

If any flame cutting, welding, etc. is done in the conveyor vicinity, take adequate precautions to ensure that no burning of any chain or other components occurs. If adequate protection cannot be provided, remove the chain and other plastic components from the conveyor and store in a safe location. Thermoplastic and similar materials can burn and give off toxic fumes. DO NOT INSTALL, OPERATE OR PERFORM MAINTENANCE ON THIS PRODUCT UNTIL YOU HAVE READ AND UNDERSTOOD THE INSTRUCTIONS CONTAINED IN THIS MANUAL.

A	
Abrasion resistance	11
Acetal	10, 11, 13
Alpine conveyors	23

B	
Backflex radius	31, 32, 33
Base chain	30
Bevel return	40

C	
Carbon steel	12
Case chain	9, 30, 38
Catenary sag	16, 24, 31, 33
Center drive	33
Chain calculation	52
Chain mass	16
Chain range	7 – 9
Chain type	25 – 28, 30, 32, 34, 35
Chemical resistance	14, 64 – 69
Chordal action	30
Coefficient of friction	56
Coefficient of thermal expansion	58
Combiner	22
Conveyor components	15, 16
Conveyor layout	17 – 24
Conveyor length	18

D	
De-combiner	22
Drive shaft	16

E	
Elevating conveyor	19, 23, 24
End drive	31

F	
Flexi chains	8

G	
Glossary of terms	59 – 60
Grip top	13, 39
Gripper conveyors	23 – 24
Grippers	23 – 24
Guide clearance	31, 34 – 38

H	
Hub type	29

I	
Idler positioning	25, 28
Idler shaft	16
Idler wheel equivalent	28

J	
Carbon steel	12

K	
Keyway	29

L	
LBP chains	4, 5, 7, 36, 37, 39
Low friction materials	6, 10, 13 – 14

M	
Magnetic chain return	42
Magnetic chains	37
Material characteristics	14, 56 – 58
Material overview	14
Material range	10 – 13
Material wear strips	51
Mechanical design	25 – 53
Multi-flex chains	8, 23, 37
Multi-hub idler	9, 28
Multi-hub sprockets	4, 5, 9, 25

N	
Number of teeth	25

O	
Offset drive	33

P	
PBT	10, 13
Pitch diameter	25 – 27, 30
Polygon effect	30
Product mass	16
Product range	7 – 9

R	
Radius configuration	17
Replacement of wear strip	51
Retainer ring	9, 13
Return way	31
Roller chain sprockets	30
Roller return	39

S	
Straight running configuration	17
Safety	70
SeleCalc	17
Serpentine return	39
Shaft	29
Side flexing chains	35
Side grip conveyors	23 – 24
Slat Top chains	7, 36, 37
Slider bed return	40
Snap-on chain	8, 13, 30, 36, 37
Solid idler	9, 28
Solid sprockets	9, 26 – 27, 30
Specialty conveyors	23 – 24
Split sprockets	9
Sprocket positioning	25 – 27
Sprockets	25 – 27, 30, 31, 33
Stainless steel	12
Symbols	53 – 54

T	
Tab return	40
Tensioner	19, 31
Thermal expansion	31, 50, 58
Transfer plates	21
Transfers	20 – 21
Trouble shooting guide	61 – 63

W	
Wear resistant	10, 12, 13, 14
Wear strip	16, 20, 26, 31, 42 – 51, 57, 61
Wheel turns	23

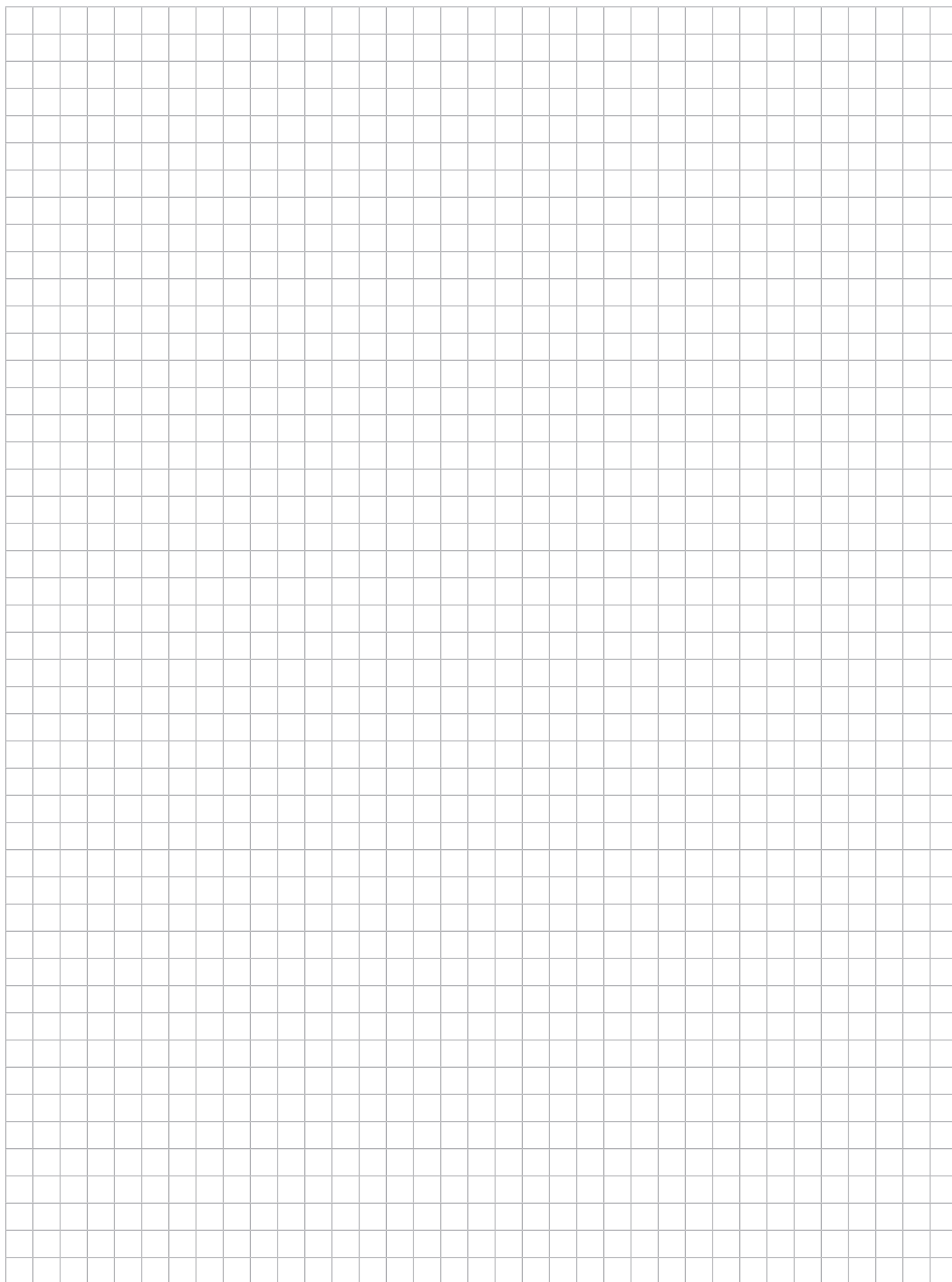



Comprehensive consulting and technical support

Profit from the best consulting and technical support in the lightweight belting industry. Local experts are always available to assist you with your belting needs. The Habasit team is proud to provide the highest levels of support, together with top-quality products that have led the global market for decades.



Belt selection and calculation assistance

We are always glad to help you select the most suitable belt for any application. We now also provide the free online tool 'SeleCalc' that makes it easy to make selections and calculations yourself. Simply register online at selecalc.habasit.com.



Fabrication, assembly and local installation services

As a full-service belting provider, we offer joining and assembly services either at our own locations or directly on your equipment.



Habasit has over 30 affiliates worldwide, each with its own inventory, fabrication, assembly and service facilities.

Together with representative offices and numerous qualified distributors, we can react quickly and efficiently to meet all your needs.



Customer training programs

To ensure the optimal performance and maximum lifespan of all our products, we offer training programs and various support tools. These include procedures for fabrication, installation, assembly, maintenance and belt repair, all of which take place at a Habasit site or at your location.



Belt monitoring, inspections, analyses and process optimization proposals

We organize and handle belt maintenance, inspections, analyses and surveys at customer sites. Upon request, we are ready to develop optimization proposals to ensure you're getting maximum value from your machinery and process output.

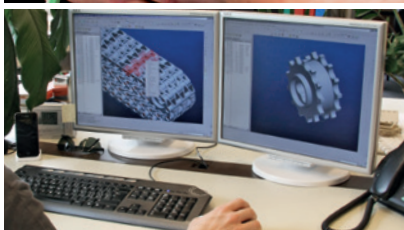

Design assistance for customized solutions

Habasit believes in building partnerships with our customers. Our engineering team will work closely with your engineers on joint design developments from initial design to final implementation. This expert service can be invaluable for projects involving new technologies or large-scale modifications and adaptations.

EMEA

Germany

Habasit GmbH, Eppertshausen
Phone: +49 6071 969 0
www.habasit.de

Switzerland

Habasit GmbH, Reinach
Phone: +41 61 577 51 00
www.habasit.ch

Austria

Habasit GmbH, Vienna
Phone: +43 1 690 66
www.habasit.at

Italy

Habasit Italiana SpA
Customer Care: 199 199 333
For int. calls: +39 0438 911444
www.habasit.it

France

Habasit France S.A.S., Mulhouse
Phone: +33 389 338 903
www.habasit.fr

Spain

Habasit Hispánica S.A.
Barberá del Vallés
Phone: +34 937 191 912
www.habasit.es

United Kingdom & Ireland

Habasit UK Ltd., Elland
Phone: +44 333 207 6570
www.habasit.co.uk

Netherlands

Habasit Netherlands BV, Nijkerk
Phone: +31 332 472 030
www.habasit.nl

Belgium & Luxembourg

Habasit Belgium N.V., Zaventem
Phone: +32 27 250 430
www.habasit.be | habasit.lu

Turkey

Habasit Kayis San.
Ve Tic. Ltd. Sti., Istanbul
Phone: +90 444 70 43
www.habasit.com.tr

Nordic countries

Habasit AB, Hindås, Sweden
Phone: +46 301 226 00
www.habasit.se

Poland

Habasit Polska Sp. z o.o.
Dąbrowa Górnicza
Phone: +48 32 639 02 40
www.habasit.pl

Russia

OOO Habasit Ltd.
Moscow Region
Phone: +7 495 966 1566
www.habasit.ru

Ukraine

Habasit Ukraine LLC., Kyiv
Phone: +38 044 290 88 99
www.habasit.ua

South Africa

Habasit South Africa Pty Ltd.
Gauteng
Phone: +27 10 001 6770
www.habasit.co.za

APAC

Japan

Habasit Nippon Co., Ltd.
Tokyo
Phone: +81 3 6820 2120
www.habasit.co.jp

China

Habasit East Asia Ltd.
Fotan, Shatin, N.T., Hong Kong
Phone: +852 2145 0150
www.habasit.com.hk

Habasit (Shanghai) Co. Ltd.
Shanghai
Phone: +8621 5488 1218
www.habasit.com.cn

Taiwan

Habasit (Taiwan) Ltd.
New Taipei City
Phone: +886 2 2267 0538
www.habasit.com.tw

India

Habasit India, Coimbatore
Phone: +91 422 666 78 00
www.habasit.in

Singapore

Habasit Far East Pte Ltd.
Singapore
Phone: +65 6862 5566
www.habasit.com.sg

Australia

Habasit Australia Pty Ltd.
Silverwater, Sydney
Phone: +61 1300 945 455
www.habasit.com.au

New Zealand

Habasit New Zealand Pty Ltd.
Auckland
Phone: 0800 000 070
www.habasit.co.nz

AMERICAS

USA

Habasit America
Suwanee, Georgia
Phone: +1 800 458 6431
www.habasitamerica.com

Canada

Habasit Canada Ltd., Oakville
Phone: +1 905 827 41 31
www.habasit.ca

Mexico

Habasit Rocua, Zapopan
Phone: +52 33 3824 2358
www.habasitrocua.mx

Brazil

Habasit do Brasil, Barueri - SP
Phone: +55 11 4789 9022
www.habasit.com.br

Habasit AG

Römerstrasse 1
CH-4153 Reinach, Switzerland
Phone +41 61 715 15 15
Fax +41 61 715 15 55
E-mail info@habasit.com
www.habasit.com

Registered trademarks
Copyright Habasit AG Subject
to alterations
6017BRO.CHA-en1125HQR